

SH  
SKH

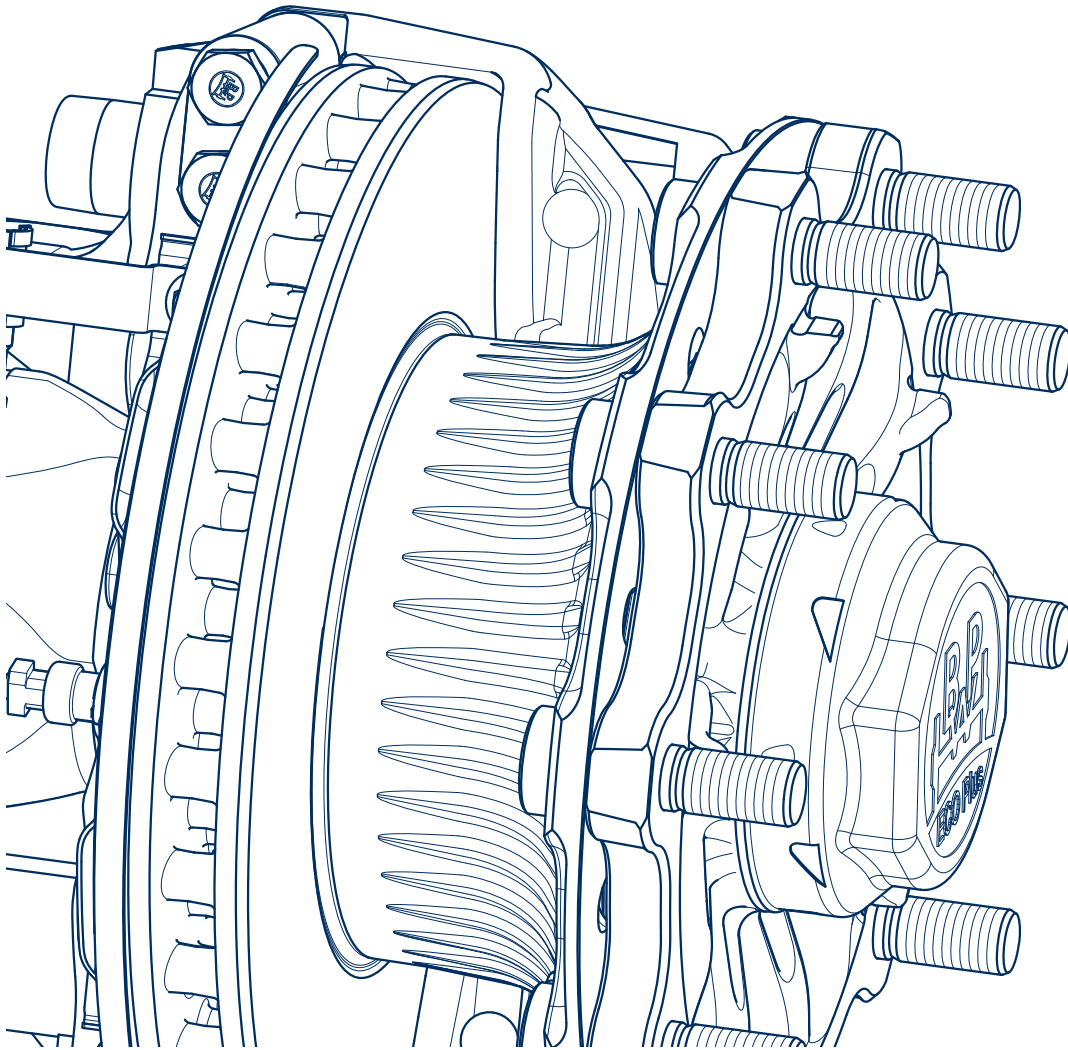

# Wear and damage characteristics on friction brakes

- Disc brake -



1<sup>st</sup> edition / 2007

Subject to change without notice.

Current versions and additional information can be found online at [www.bpw.de](http://www.bpw.de).

---

# Inhaltsverzeichnis

◎ 1.	<b>Overview .....</b>	<b>Page 4</b>
◎ 2.	<b>Foreword.....</b>	<b>Page 5</b>
◎ 3.	<b>Introduction .....</b>	<b>Page 6</b>
◎ 4.	<b>Operation / construction .....</b>	<b>Page 7</b>
◎ 5.	<b>Comparison between disc and drum brakes .....</b>	<b>Page 8</b>
◎ 6.	<b>Inspection and maintenance .....</b>	<b>Page 8</b>
◎ 7.	<b>Assessment of wear.....</b>	<b>Page 9</b>
◎ 8.	<b>Damage profiles and states of wear.....</b>	<b>Page 10</b>
8.1	Thermal destruction of the brake	Page 10
8.2	Extreme contamination of the brake	Page 11
8.3	Edge contact between backplate and brake disc	Page 12
8.4	Slanting wear due to offroad use	Page 13
8.5	Uneven wear due to sticking brake callipers	Page 14
8.6	Severe corrosion in the brake calliper	Page 15
8.7	Overheated boots	Page 16
8.8	Edge pitting on the pad	Page 17
8.9	Crack formation on a pad	Page 18
8.10	Pad at wear limit	Page 19
8.11	Disregarding the pad wear limit	Page 20
8.12	Thermally overloaded brake disc with crack	Page 21
8.13	Thermally overloaded brake disc due to disregarding of pad wear limit	Page 22
8.14	Pad impression on the brake disc	Page 23
8.15	Corrosion in the brake cylinder	Page 24
8.16	Leaking clamping band on the brake cylinder	Page 25
◎ 9.	<b>List of keywords .....</b>	<b>Page 26</b>
◎ 10.	<b>Notes.....</b>	<b>Page 27</b>

---

# 1 Overview

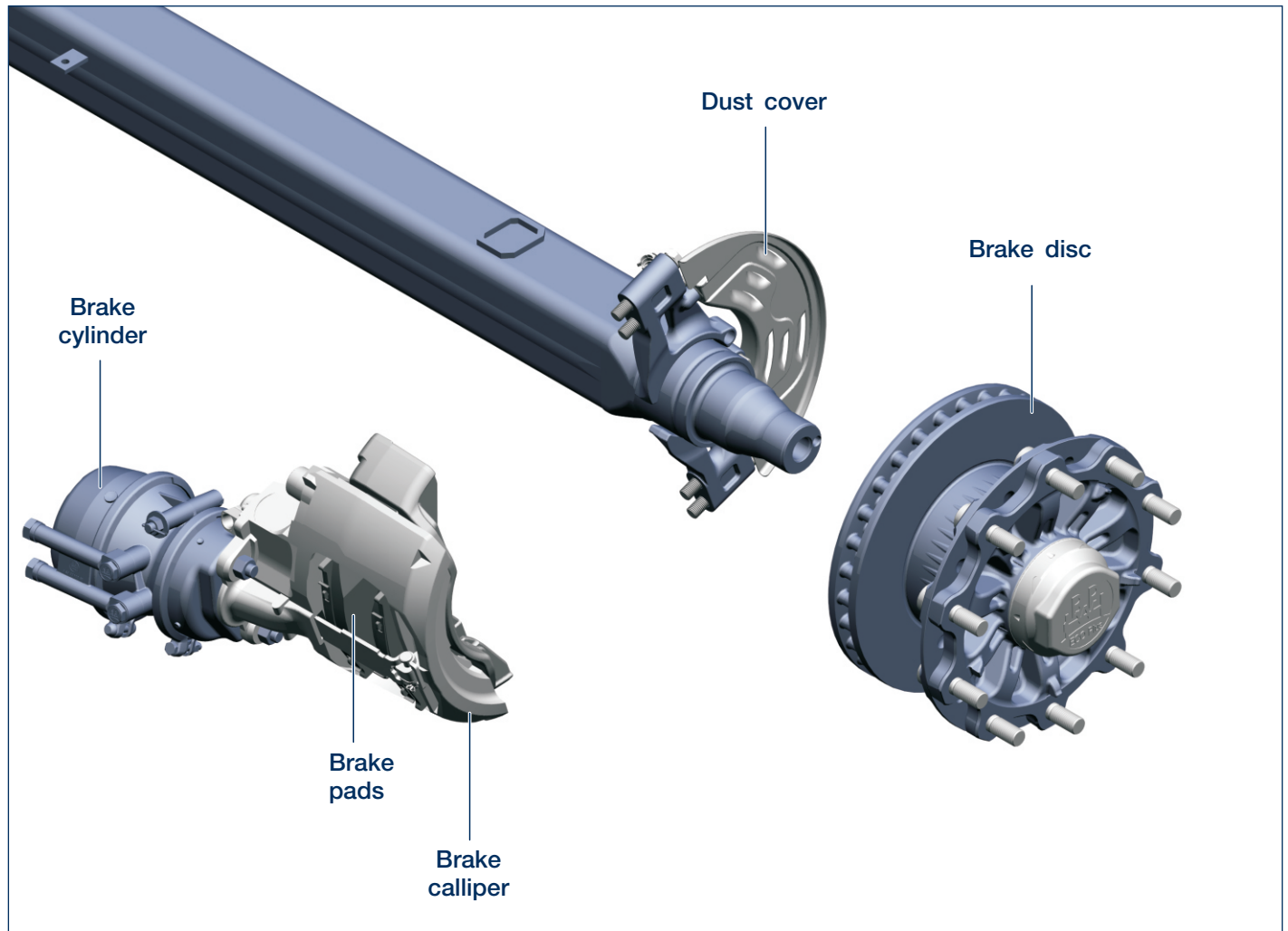

# Foreword 2

The purpose of this brake engineering publication for discbraked commercial vehicles is to explain wheel brakes. It is aimed at vehicle manufacturers, haulage contractors, workshops, testing centres, drivers and, in general, anyone interested in commercial vehicles.

The document serves as a guide in the assessment of possible cases of wear and damage. The objective is to provide decision aids which can be used to distinguish between normal wear and misuse of brakes.

Typical wear and damage profiles to disc brakes and their components are summarised in this catalogue. The findings, causes and repercussions of each case of damage are explained in detail. In addition, specific suggestions for remedial action are provided.

## **Team of authors**

Mr. M. Pehle

Mr. Dr. B. Meurer

Mr. U. Dabringhausen

Mr. R. Eskes

Mr. J. Flick

Mr. K.R. Lang

Mr. H. Paech

Mr. S. Pielen

Mr. M. Pilz

Mrs. J. Schrödler

Mr. Dr. J. F. Franke

## 3 Introduction

During recent years, the disc brake has benefited from remarkable progress in the commercial vehicle sector.

Increased use of the disc brake in commercial vehicles started when the pneumatically operated version was demonstrated at the IAA 1996. Since then, the disc brake has been able to capture a considerable market share for heavy commercial vehicles in central Europe. This is primarily due to the safety aspect of the disc brake's favourable fading properties: Even at high brake temperatures, it offers a consistently high level of braking effort.

In the intervening period, all European tractor vehicle manufacturers have started equipping their vehicles with this technology. The disc brake has also made progress in Central Europe in the trailer area. In the early 1990s, BPW started to develop discbraked trailer axles and started series production in 1996 at the same time as the tractor vehicle industry.

---

# Operation / construction

## 4

The chart shows a typical pneumatically operated disc brake for trailers and semitrailers.

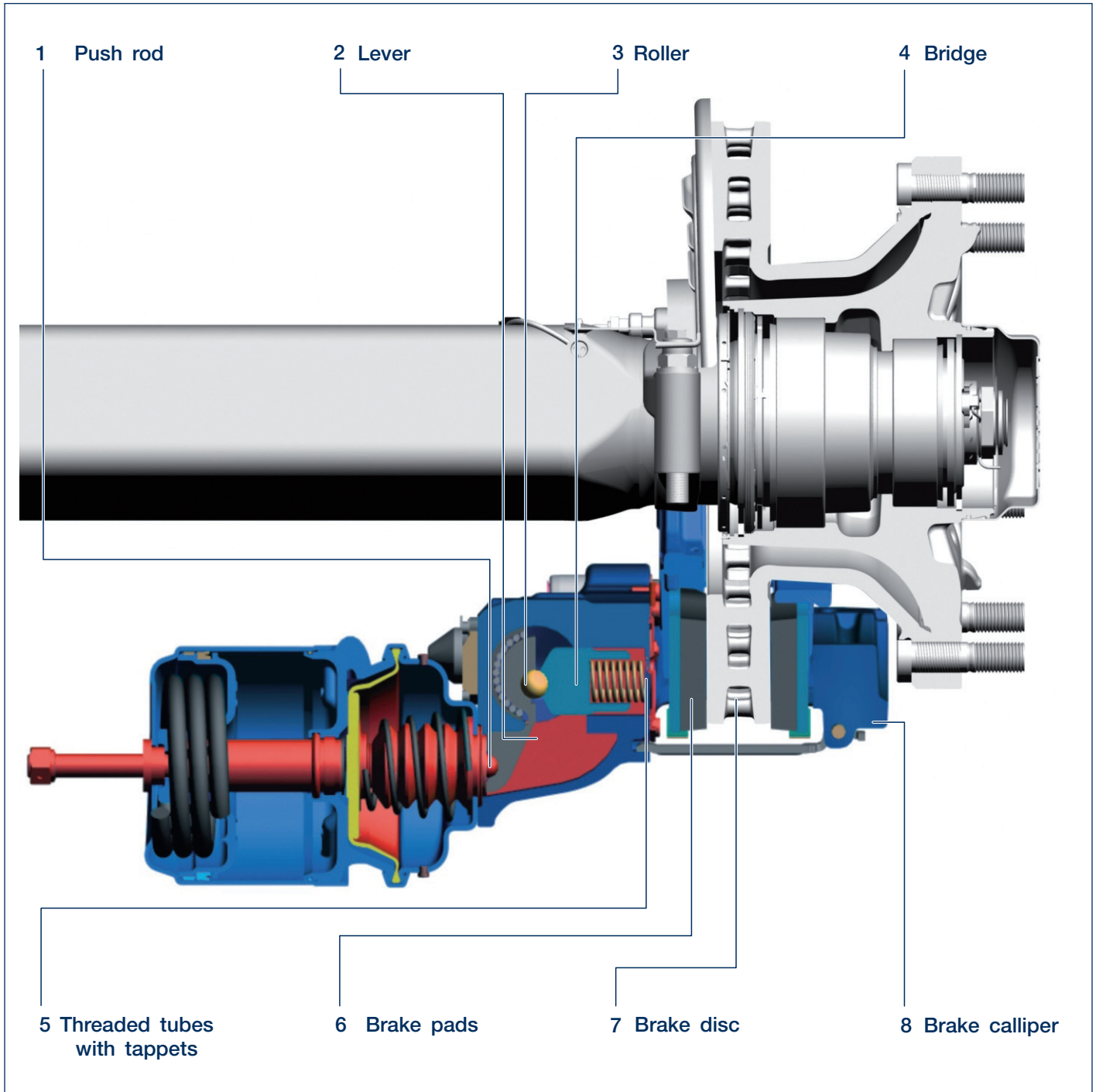

When the brake pedal is pressed, the push rod (1) of the brake cylinder presses against the lever (2) of the brake calliper. The roller (3) mounted eccentrically in the brake transfers the force onto the bridge (4). The clamping force acts on the internal brake pad (6) via the threaded tubes and tappets (5). As a result, the brake pad (6) is forced against the brake disc. The reaction force which now arises on the calliper (8) is transferred to the opposite brake pad (6) by means of the sliding carrier, so that the opposite pad is also pressed against the brake disc with the same force. When the brake pressure is reduced, the spring force returns the bridge, the threaded tubes (4) and lever (2) to their original position.

## 5 Comparison between disc and drum brakes

The advantages of disc brakes concern safety. Geometrical advantages mean that the braking effort is only reduced slightly as temperatures rise (low fading). This is because of the flat contact surface between the brake disc and the brake pads, which only changes to a slight extent even at relatively high temperatures. Furthermore, the thermal expansion of the brake disc and the brake pads tends to reduce the required brake cylinder stroke.

During operation, disc brakes become significantly hotter than drum brakes with similar performance data. This means the components of the disc brake are subject to significantly higher thermal stress. Dealing with these higher temperatures was always a main focus of material developments.

Disc brake technology was developed further at BPW's initiative. The wear and crack resistance of the brake discs and pads has been improved. This means modern disc brakes can be operated in comparatively higher temperature ranges, and achieve long service lives at the same time.

Markets with more exacting requirements in terms of brake robustness will continue to be served with drum brakes to an overwhelming extent. Their enclosed construction method means they are largely protected against moisture and dirt. The disc brake has also undergone further development in this area: The BPW Disc Protector is a cover plate that protects the disc brake against coarse dirt during operation. The cavity cover has a similar effect. The less dirt that can get onto the disc, the more reduced and even the wear on the brake pads will be.

The tangential screw connection has made the attachment of the brake calliper to the axle significantly more straightforward in terms of servicing. To this end, the number of bolts has been reduced and it has also been made possible to reach them with nutsetters.

In spite of these improvements, incorrect operation or activation problems with incorrect matching between the tractor and trailer can lead to damage to the brake components.

This document presents and explains various examples of damage and wear conditions on disc brakes, their causes, effects and possible remedial action.

Other explanations and information are available in the BPW commercial vehicle catalogue and the corresponding workshop manuals.

## 6 Inspection and maintenance

In order to maintain the operating and road safety of the vehicle, the maintenance work specified by the vehicle or component manufacturer must be carried out at the intervals indicated. During this, particular attention is to be paid to the condition of the braking system.

BPW components should always be maintained in accordance with the information contained in the relevant workshop manual.

Maintenance work must be carried out in specialist workshops or on the vehicle owner's premises by trained experts in suitably equipped workshops.

Components should only be renewed by genuine components, as even tested and cleared generic products can display undesired effects when they interact with genuine components. In individual cases, using generic products can result in undesired and very costly repairs.



## 8.1 Damage pattern: Thermal destruction of the brake and extreme pad wear

**Component: Complete brake**

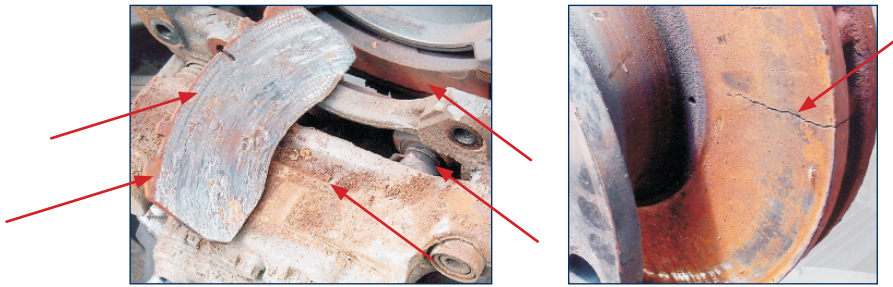

### Findings:

The brake calliper has a reddish discolouration, in particularly on the piston side and in the brake cavity, and is covered with a layer of corrosion.

One covering boot of the piston has already been destroyed. The brake pad lining plate of the pad is worn along the entire surface and has a noticeable red discolouration in the edge area. Remains of the metal grid attachment are still visible in places, the brake pad is completely worn down.

The brake disc has red discolouration. The braking surface facing the hub neck is covered with flash rust, there are only bright spots remaining in the outer edge area. A continuous crack can be seen in the brake disc. There are other smaller heat cracks below the layer of flash rust.

### Cause:

The brake pads wear faster if a disc brake is exposed to high temperatures. If this is not noticed in good time by inspection and maintenance work, the brake pads may wear down completely with the result that the brake pad lining plates start making friction contact with the brake disc. This metal-on-metal friction can lead to temperatures in the forging and smelting range at some points. This heat acts on almost all brake components and the braking surfaces of the disc. Only the screw-on surface of the hub neck and parts of the brake calliper are not exposed to such high temperatures - some remnants of the original paint can still be seen here.

If there is damage on all the brakes of a vehicle, it may have been caused by an aggressive driving style, incorrect matching between the tractor and trailer or brakes that are too small for the application.

If there is damage on individual wheel brakes, it may have been caused by a defect in the particular wheel brake or a defect in the brake pressure pneumatic circuit in question.

### Repercussions:

The destruction of the covering boot of the piston can allow moisture and dirt to penetrate the brake calliper and lead to corrosion. This destroys the adjusting device. The brake calliper and the overheated, cracked brake disc are unusable.

### Remedial action:

All worn and overheated components must be renewed. We recommend using genuine parts.

If the damage has occurred on all brakes of a vehicle, the matching between the tractor and the trailer should be checked if possible. A careful and predictive driving style can help to avoid such overloadings of the brake.

If there is damage on individual brakes, the components and the affected brake pressure pneumatic circuit must be checked and repaired if faulty.

BPW disc brake axles can have the Brake Monitor retrofitted to them. This can be attached in a clearly visible location on the vehicle and indicates when the brake pad wear limit has been reached.

Vehicle owners and vehicle operators are obliged to carry out maintenance and services in accordance with the stipulations of the vehicle manufacturer and, in particular, are to regularly check the operational safety of braking systems.

## 8.2 Damage pattern: Extreme wear to the brake in off-road use

Component: Complete brake

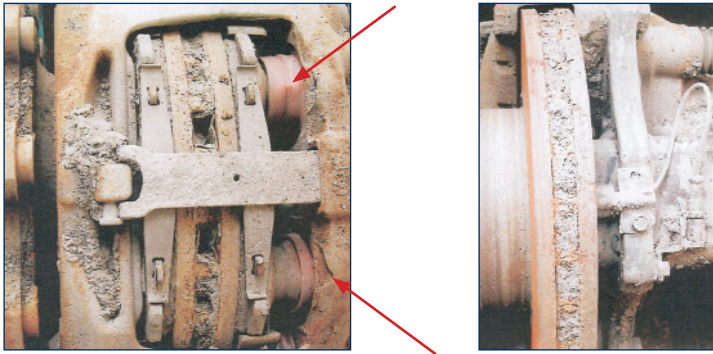

### Findings:

The brake cavity and the cavities in the ventilated brake disc are blocked with earth and mud residues. The brake displays significant traces of corrosion, the stop projections of the pads have white discolouration. The seal of the piston at the top of the picture is bent over and has moved closer to the brake pad lining plate. The pads are evenly worn down.

### Cause:

Such advanced wear is caused by driving on very dirty or muddy roads. More and more dirt collects on and in the brake during this process. These encrustations with mud increasingly prevent the pistons and their boots from moving.

### Repercussions:

In this condition, the brake can still provide adequate braking values. However, failures can be expected within a very short period of time due to increasing obstructions of the clamping and return movements. It becomes more difficult for the brake calliper to move laterally in its sliding seat and the pistons cannot move out and in correctly any longer. This means the brake pads are not pressed against the brake disc flat. Slanting and one-sided wear results. Cooling of the brake disc by circulating air is rendered impossible because the cavities are blocked, which means overheating can be expected before very long.

### Remedial action:

A brake with this level of contamination urgently requires cleaning. Heavily corroded and damaged parts must be renewed. We recommend using genuine parts. BPW disc brake axles can be retrofitted with a cavity cover as well as the Disc Protector. These cover plates for disc brakes protect the brake against coarse dirt and extend its service life.

Drum brakes are better suited to operation on rough ground. Their encapsulated design means they are better protected against penetration by dirt and mud.

## 8.3 Damage pattern: Edge contact between backplate and brake disc

### Component: Bremsscheibe und Pads

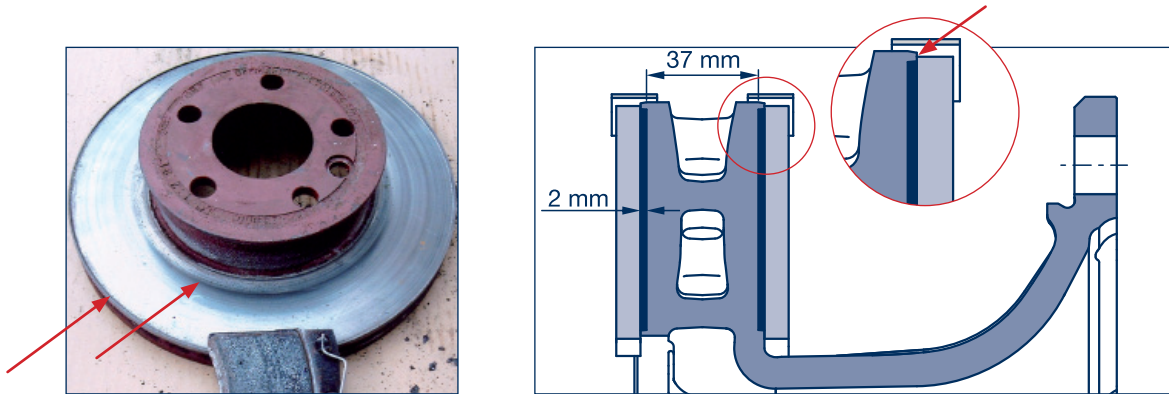

#### Findings:

This brake disc is approaching its wear limit. Narrow wear edges have been left on the inside and outside edges of the braking surface, corresponding to the height of the original disc thickness. The braking surface is evenly worn, without distortion, scorched spots or heat cracks. The associated pads display even wear, the wear limit has been reached. It is noticeable that the brake pad lining plates have been in ring-shaped friction contact with the hub neck of the disc in the area of the outside edges.

#### Cause:

Although the brake pads are evenly worn, they have not covered the entire braking surface. With increasing wear, the brake pads have gouged their way into the braking surface and have left wear edges on the inside and outside edges. During their use, the brake disc and brake pad have worn down in the unfavourable one-to-one ratio, which means the braking surface thickness and the brake pad thickness have diminished to an equal extent. From a certain point onwards, the height of the wear edges matched the thickness of the remaining pad. Then, the brake pad lining plates (which are wider than the brake pad) came into contact with the projecting edges during braking.

#### Repercussions:

The contact pressure was no longer being applied to the brake pads and the braking surface, but instead acted on the wearing edges and brake pad lining plates. Despite having worn-down pads, a disc brake can still display adequate braking values on the dynamometer test rig. However, this can cause unwanted noise or uneven deceleration.

#### Remedial action:

The wear on the brake disc and the pads must be checked regularly. The brake disc and brake pads represent a combination of materials that establish a certain amount of friction when pressed together. The softer friction partner, namely the brake pad, is intended to wear more rapidly than the brake disc. The degree to which the disc and brake pad wear relative to one another is described as the wear ratio. The edge formation on the brake disc must be assessed when the pads are changed. The edges are allowed to be ground down if the disc has not reached its wear limit yet.

It is always to be recommended that tested and approved qualities as well as mutually compatible combinations should be used

## 8.4 Damage pattern: Slanting wear due to offroad use

Component: Complete brake



### Findings:

This brake pad reveals severe slanting wear. Significant indentations into the brake cavity can be seen on the brake calliper.

### Cause:

Driving on unconsolidated tracks with potholes can result in this kind of damage to disc brakes. The frequent and powerful shocks cause the brake pad lining plates to work into the brake frame, causing the pads to cant and tilt during braking.

### Repercussions:

Tilting leads to slanting wear on the brake pads. A slight amount of play is restored when the brake is released. The bearings of the brake calliper are highly stressed by the slanted pads and they wear prematurely. In addition, the slant means that the brake pads wear down very quickly. If the damage to the brake is not rectified, the brake pad lining plates will come into friction contact with the brake disc and can cause irreparable damage to it.

### Remedial action:

Damaged components must be renewed. We recommend using genuine parts.

Drum brakes are better suited to operation on rough ground.

## 8.5 Damage pattern: Uneven wear due to sticking brake callipers

Component: Brake pads

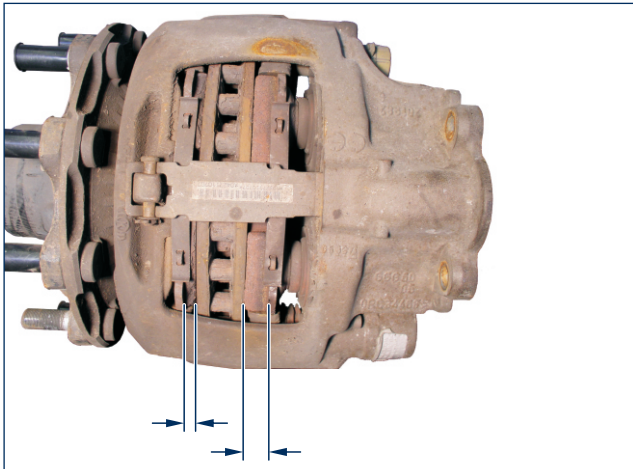

### Findings:

Severe one-sided wear on brake pads in conjunction with seized brake calliper

### Cause:

Leaks in the area of the guide pin allow moisture to penetrate, leading to corrosion and seizure of the pilot bearings.

### Repercussions:

The brake calliper is unable to slide back into its starting position after the brake is released, and therefore the outer pad rubs against the brake disc. This leads to increased wear on the outer pad.

### Remedial action:

The pilot bearings and bushes must be renewed if this damage occurs.

Vehicle owners and vehicle operators are obliged to carry out maintenance and services in accordance with the stipulations of the vehicle manufacturer and, in particular, are to regularly check the operational safety of braking systems.

In order to prevent the damage described here from occurring, the seals of the pilot bearings must be carefully checked during inspections and renewed in case of damage.

## 8.6 Damage pattern: Severe corrosion in the brake calliper

Component: Brake calliper

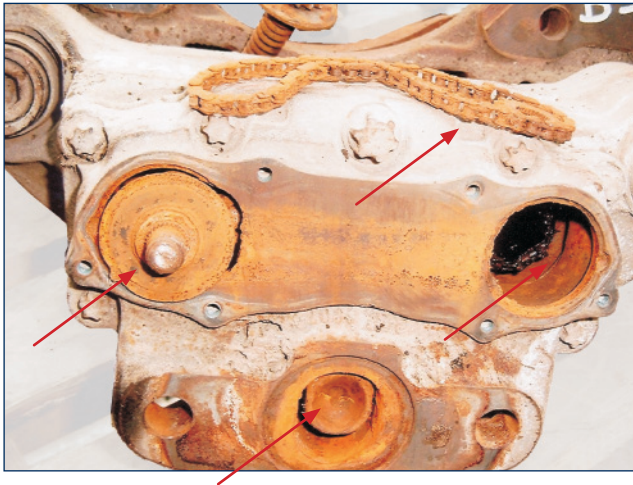

### Findings:

The picture shows the area of the adjusting device for the clamping mechanism with the two pistons. All internal components are covered by a rusty red layer of corrosion, and the links of the adjusting chain are particularly severely affected. The brake cylinder mount and the spherical cup that is inside it are affected in the same way. The entire external surface of the brake calliper reveals a striking white covering.

### Cause:

The white colouring of the outside housing demonstrates that this vehicle has also been used on unconsolidated roads. The dust swirled up there combines with the frequent precipitation to create a mud that adheres to components underneath the vehicle in particular. This mud has a very small particle size, which means it can penetrate even the smallest gaps and lead to corrosion. In this case, it was presumably a defective brake cylinder boot that allowed the mud to penetrate and give rise to moisture in the brake calliper. This resulted in contamination and severe rusting, in particular in the adjusting mechanism.

### Repercussions:

Rust and mud residues soon spread throughout the interior of the brake calliper. The adjusting mechanism, the pistons and the clamping mechanism of the brake calliper have their movement severely restricted. The braking power is reduced and does not recover.

### Remedial action:

Leaks in brake cylinders are hard to spot from the outside. For this reason, shorter maintenance intervals are prescribed for off-road applications so that damage of this kind can be detected earlier.

The encapsulated design of drum brakes mean they are less sensitive to dirt and are therefore better suited to off-road use.

## 8.7 Damage pattern: Overheated boots

Component: Brake calliper

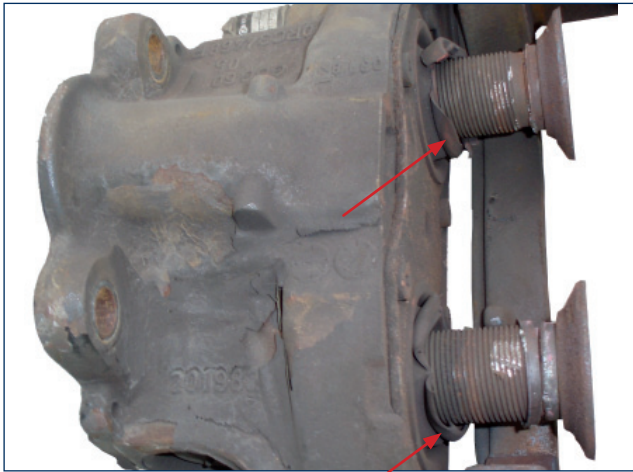

### Findings:

The picture shows the area of the clamping mechanism with the two pistons. The boots have been entirely scorched away.

### Cause:

Thermal overloading of the brake leads to overheating and destruction of the boots. If all wheel brakes are affected, it may have been caused by incorrect matching between the tractor and trailer, an aggressive driving style or a brake that is too small for the application. If only individual wheel brakes are affected, they may be faulty or there might be defects in the associated compressed-air brake circuits.

### Repercussions:

The damaged boot allows moisture to enter the interior of the brake, leading to corrosion. This soon spreads throughout the interior of the brake calliper. The functions of the adjusting mechanism and the pistons are significantly impaired with the effect that braking power is gradually lost as the level of wear increases. The result may be brake failure if the damage is not noticed and rectified in good time.

### Remedial action:

The pneumatic circuit and all components of the affected brake(s) must be checked. Overheated and damaged components must be renewed. We recommend using genuine parts. Check the matching between the tractor vehicle and trailer if necessary. A careful and predictive driving style can help to avoid overloadings of this type.

## 8.8 Damage pattern: Edge pitting on the pad

Component: Pad



### Findings:

The pad has a remaining thickness of about half of the new condition. The pad halves are evenly worn down. A layer of carbon has formed on their surface due to the effect of friction, which is an indication of a brake that is functioning well. The pitting on the edges of the pads is a striking feature.

### Cause:

The cause of the pitting is splashing water penetrating to the brake pad in the area of the clamping clip, leading to corrosion. The corrosion causes the affected areas of the pad to swell, they lose their adhesion to the adjacent pad layers and are stripped off by the effect of the braking forces.

### Repercussions:

It must be expected that the pitting will increase in area. The size of the braking surface is reduced by the pitting, thereby causing the effectiveness of the brake to decline gradually.

### Remedial action:

Edge pitting and cracks up to a certain extent (to about 10% of the pad surface) are signs of normal wear. The pad adhesion zone (pad thickness to 2 mm above the brake pad lining plate) is not allowed to have any pitting or cracks. Pads with greater levels of pitting must be renewed. We recommend using genuine parts.

## 8.9 Damage pattern: Crack formation on a brake pad subjected to high thermal load

**Component: Pad**



### Findings:

The brake pad thickness is almost still the same as the original thickness when new. This is indicated by the bevels on the left and right edges. The slanted surface on the right of the picture has been attacked by corrosion. Numerous heat cracks have formed on the surface of the pad. The crack depth is only slight in relation to the remaining pad thickness. Some crossways cracks have joined up and extend along the entire width of the pad. Only a slight layer of carbon has been caused by friction on the pad surface.

### Cause:

The pad has been subjected to short, sharp braking. There have been very high temperatures on the surface, but because of the fact that the loading only occurred briefly these temperatures did not penetrate into the deeper layers of the pad. This superficial heat caused the binding agents to become vaporised and heat cracks resulted.

### Repercussions:

The cracked surface will be abraded off relatively quickly during driving, which means the wear limit can be expected to be reached prematurely. The heat cracks are a sign of elevated thermal loading, but are not critical in themselves.

### Remedial action:

There is no need to renew these pads providing the cracks do not extend into the area of the pad adhesion zone and do not run horizontally to the lining plate.

A careful and predictive driving style can help to prevent such overloadings of the brakes.

## 8.10 Damage pattern: Brake pad at the wear limit

Component: Pad



### Findings:

The friction lining of this pad has reached the wear limit. Its remaining thickness is only two millimetres. The picture shows marked heat cracks on the pad surface. The binding agents have already vaporised at a few points on the pad and parts of the pad surface have broken off. The broken areas have been attacked by corrosion.

### Cause:

The pad used has a typical wear pattern without signs of overloading. The pad has already worn down to the pad adhesion zone (remaining pad thickness 2 mm).

### Repercussions:

Adequate braking values can still be achieved in the lower to middle area of the pad. If the brake pad is not renewed immediately, there is a danger that the remaining pad will lose its adhesion completely during full-on braking and may also flake away. The brake would fail.

### Remedial action:

The pad must be renewed because the brake pad has reached its wear limit. We recommend using genuine parts. BPW disc brake axles can have the Brake Monitor retrofitted to them. This can be attached in a clearly visible location on the vehicle and indicates when the brake pad wear limit has been reached.

## 8.11 Damage pattern: Disregarding the wear limit

### Component: Pad



#### Findings:

This brake pad lining plate has been in direct friction contact with the brake disc over its entire area. None of the pad's friction lining remains. The even abrasion on the brake pad lining plate indicates even clamping by both pistons, so the adjusting mechanism is undamaged.

#### Cause:

The wear limit of this pad has been significantly exceeded. The direct friction contact between the brake disc and the brake pad lining plate led to temperatures in the forging and smelting range at some points.

#### Repercussions:

After the wear limits have been exceeded, the pads and the brake discs are irreparably damaged (see page 21). In addition, there may be damage to the brake calliper and complete failure of the brake might result.

#### Remedial action:

Pads that have reached their wear limit must be renewed. Other components of the brake must be checked for damage and renewed if necessary. We recommend using genuine parts. It is essential to respect the wear limit!

BPW disc brake axles can have the Brake Monitor retrofitted to them. This can be attached in a clearly visible location on the vehicle and indicates when the brake pad wear limit has been reached.

Vehicle owners and vehicle operators are obliged to carry out maintenance and services in accordance with the stipulations of the vehicle manufacturer and, in particular, are to regularly check the operational safety of braking systems.

## 8.12 Damage pattern: Thermal overloading with cracking of the brake disc

**Component: Bremsscheibe**



### Findings:

The damage pattern shows a crack through a ventilated brake disc; the disc itself displays little wear. Furthermore, the brake disc reveals heat cracks due to high thermal load.

### Cause:

Thermal overloading of this kind is caused by excessively frequent, intermittent sharp braking. This results in high levels of alternating thermal loads which give rise to internal stresses leading to a crack through the brake disc. Other possible causes can be identified as incorrect matching between the tractor vehicle and trailer or overloading of the trailer.

### Repercussions:

The cracks through the brake disc reduce its stability. Under extreme circumstances, the brake disc can fracture, resulting in complete brake failure.

### Remedial action:

The thermally overloaded disc must be renewed. The other components of the brake must be checked and renewed if necessary. We recommend using genuine parts. Correct matching between the tractor vehicle and trailer, avoiding overloading and driving with a careful, predictive style can help to avoid such damage.

## 8.13 Damage pattern: Thermal destruction of the brake due to extreme brake pad wear Component: Bremsscheibe

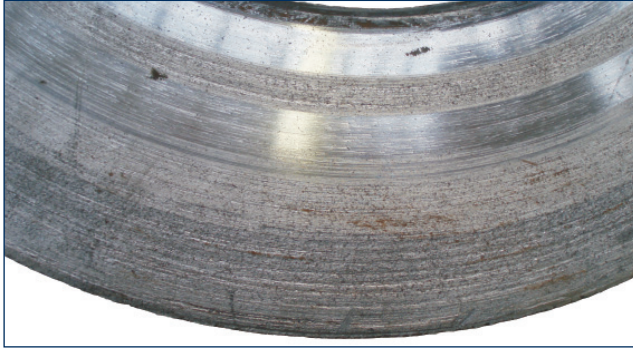

### Findings:

The picture shows a brake disc with its surface covered by fused metal.

### Cause:

The cause of damage such as this is failure to respect the brake pad wear limit. If the brake pads are worn down to such an extent that the brake pad lining plates come into contact with the brake disc during braking, this gives rise to temperatures in the smelting range at some points and the braking surface can melt there (see page 19). The molten metal is smeared over the surface of the disc.

### Repercussions:

The brake disc exceeds the permitted limits of wear and scoring. If braking continues in this condition, overheating can result in further damage and ultimately total failure of the brake.

### Remedial action:

Brake discs with excessive levels of scoring must be renewed (see wear assessment on page 8). Other components of the brake must be checked for damage and renewed if necessary. We recommend using genuine parts.

It is essential to respect the wear limits of brake discs and brake pads.

BPW disc brake axles can have the Brake Monitor retrofitted to them. This can be attached in a clearly visible location on the vehicle and indicates when the brake pad wear limit has been reached.

Vehicle owners and vehicle operators are obliged to carry out maintenance and services in accordance with the stipulations of the vehicle manufacturer and, in particular, are to regularly check the operational safety of braking systems.

## 8.14 Damage pattern: Pad impression on the brake disc

**Component: Bremsscheibe**

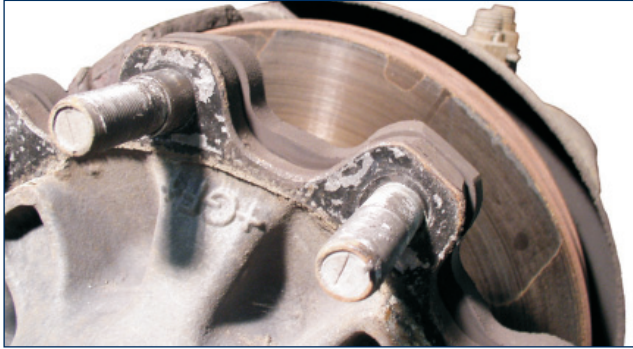

### **Findings:**

The picture shows a brake disc with an irregular, crack-like feature running along its braking surface. However, this is not a stress or heat crack but actually an impression of the pad contour.

### **Cause:**

The metal constituents of brake pads mean they are exposed to attack by corrosion. The brake pad is held in direct contact with the brake disc when the parking brake is applied, therefore it transfers the pad contour to the braking surface and leaves stationary marks behind.

### **Repercussions:**

The appearance does not have a negative influence on the effectiveness and expected service life of the brake.

### **Remedial action:**

The standstill marks will be abraded off after the brakes have been applied a few times.

## 8.15 Damage pattern: Corrosion in the brake cylinder

**Component: Federspeicher-Membranbremszylinder**



### Findings:

The picture shows a spring-loaded diaphragm brake cylinder of a disc brake. A striking feature is the misalignment of the piston that protrudes out of the screw-on surface towards the brake calliper. When opened for assessment, the brake cylinder reveals corrosion to the compression spring, piston and housing cover.

### Cause:

No drainage hole was opened on this brake cylinder. This means the moisture that enters the cylinder with the inflow of atmospheric air was unable to escape and gave rise to corrosion on the components. The piston shown in the left-hand picture is slightly misaligned.

### Repercussions:

The slight misalignment of the piston is unproblematic. However, if the misalignment is considerable then the piston rod will press into the gap between the spherical cap and the brake calliper and become jammed - the brake would no longer be fully actuated or fully released.

A heavily corroded compression spring can break under load and damage both the diaphragm and the boot. This would result in moisture penetrating the brake calliper leading to corrosion and associated stiffness with a loss of braking power. Furthermore, the broken fragments of the spring can prevent the return movement of the piston and thereby impair the release of the brake.

### Remedial action:

With brake cylinders, it is essential to make sure that the lowest drainage hole is opened. The other holes must remain closed. Brake cylinders are only allowed to be serviced and repaired in an appropriately equipped specialist workshop. For reasons of safety, never open spring-loaded accumulators!

## 8.16 Damage pattern: Leakage in the area of the clamping band

**Component: Federspeicher-Membranbremszylinder**



### Findings:

This spring-loaded diaphragm brake cylinder is losing air in the area of the clamping band for the service brake section.

### Cause:

Diaphragms are wearing parts and subject to an ageing process. After several years of operation, leaks can result in the clamping area of the diaphragm and the clamping band, leading to a gradual pressure loss.

### Repercussions:

In spite of the leak, there is no reason to expect sudden total failure of the brake cylinder and therefore of the wheel brake. The air only escapes slowly. The drop in reservoir pressure is made good when the vehicle is driven. If the vehicle is parked up for a long time, however, all the pressure in the service brake system can escape and require re-establishing. The parking brake system will thus remain activated for longer.

If the operating pressure drops whilst the vehicle is being driven, the driver will be made aware of the pressure loss by a warning device. This warning must be respected because a major pressure loss will lead to the trailer brakes being activated automatically. The vehicle must not continue to be driven in this case.

### Remedial action:

Defective brake cylinders must be renewed. We recommend using genuine parts.

## 9 List of key words

		page
Components	· Brake disc	14, 21, 22, 23
	· Brake calliper	15, 16
	· Brake cylinder	24, 25
	· Pads	17, 18, 19, 20
	· Complete brake	10, 11, 12, 13
Keyword	· Corrosion	14, 15, 24, 25
	· Cracks / destruction	16, 18, 21
	· Thermal overload	10, 11, 15, 16
	· Wear	10, 12, 13, 14, 17, 19, 20, 22, 25
Causes	· Aggressive / inappropriate driving style	10, 15, 16, 18, 21
	· Damage related to use	11, 13, 21
	· Inspection/repair omitted or not performed correctly	10, 14, 20, 22, 24
	· Preliminary damage	15, 22
	· Brake matching	10, 16

---

# Notes 10



BPW-V-SB 39021401e

**BPW is a globally leading manufacturer of intelligent running gear systems for trailers and semi-trailers. As an international mobility and system partner, we offer a wide range of solutions for the transport industry from a single source, from axle to suspension and brake to user-friendly telematics applications.**

**We thereby ensure outstanding transparency in loading and transport processes and facilitate efficient fleet management. Today, the well-established brand represents an international corporation with a wide product and service portfolio for the commercial vehicle industry. Offering running gear systems, telematics, lighting systems, composite solutions and trailer superstructures, BPW is the right system partner for automotive manufacturers.**

**BPW, the owner-operated company, consistently pursues one target: To always give you exactly the solution which will pay off. To this end, we focus our attention on uncompromising quality for high reliability and service life, weight and time-saving concepts for low operating and maintenance costs as well as personal customer service and a close-knit service network for quick and direct support. You can be sure that with your international mobility partner BPW, you always use the most efficient method.**

# Your partner on the path to economic viability



**BPW Bergische Achsen Kommanditgesellschaft**

Postbox 12 80 · 51656 Wiehl, Germany · Phone +49 (0) 2262 78-0  
info@bpw.de · [www.bpw.de](http://www.bpw.de)