

Axle Guide



RUNNING GEARS FOR COMMERCIAL VEHICLES

- ▶ SELECTION
- ▶ DESIGN
- ▶ INSTALLATION

we think transport



Revision status:

Revision	Page	Action
00 (2023-06-01)		New publication
01 (2024-09-01)	30	LightTube added to table
	40	Chapter 1.4.3 Support devices added
	68	Steering roll radius calculation corrected
	78	Chapter 2.8.2 Tyre pressure monitoring added
	80 - 81	Headline and description of ARC adjusted
	87	Chapter 2.8.7 iC Plus running gear added
	97	Description of parking and parking brake updated
	99	CCF brake cylinder added
	100	Conformity test CCF brake cylinder added
	102	Chapter 3.3.2 Retrofitting ABS sensor added
	107	Pressure rod length of base plate F corrected
	108	Base plate F removed
	122	Graphics updated
	123 - 125	Assembly wear sensing for lining shaft cover added
	127	Complete page added
	176	Tightening torque for lower air bag screw connection updated
	203	Overview of trailing arm versions added
	208	Hollow profile trailing arm LightTube added
	209 - 210	Bullet points added

Revision	Page	Action
01 (2024-09-01)	234	Figure Axle lift bolt-on support updated
	239	Tightening torque under air bag screw connection updated
	248	Height compensation * added
	253 - 256	Struts, cross members etc. adjusted
02 (2024-12-13)	10	Wheel connection 275/8 for SN 3020 deleted
	13	Link data sheet ALII - TS2 updated
	29	Link Brochure BPW turntables updated
		Link Installation and maintenance instructions for BPW turntables added
	30	LightTube available for - ALMT changed to ALU
	31	Link ECO Plus Warranty documents updated
	58	Max. clamping lengths adapted
	92	Page 2 and 3 of the brake data added
	93	Link to the test reports SN 3010, SN 4218 and SN 4220 updated
	117	Link to the TS2 workshop manual updated
	132	Link to the Maintenance instructions and Warranty documents updated
	182	Link to the Maintenance instructions and Warranty documents updated
	243	Link data sheet ALII - TS2 updated

Valid: 2024-12-13

3rd edition

Subject to changes. The current version and additional information can be found online at

www.bpw.de

Overview of the Content

<h2>1 PROGRAM RUNNING GEARS FOR COMMERCIAL VEHICLES</h2>	<ul style="list-style-type: none"> 1.1 Overview 1.2 Running gears 1.3 Recommendation for use 	<ul style="list-style-type: none"> 1.4 Website / Configurator / Further products 	
<h2>2 AXLES</h2>	<ul style="list-style-type: none"> 2.1 Identification 2.2 Track width 2.3 Wheel connections 2.4 Self-steering axles 	<ul style="list-style-type: none"> 2.5 Forced steering axles 2.6 Stub axles 2.7 Swing axles 2.8 Additional equipment 	
<h2>3 BRAKES</h2>	<ul style="list-style-type: none"> 3.1 Design, test reports, calculation 3.2 Brake cylinder 3.3 ABS sensor, exciter ring 	<ul style="list-style-type: none"> 3.4 Base plates for drum brake axles 3.5 Slack adjuster ECO-Master 3.6 Drum brake ECO Drum 	<ul style="list-style-type: none"> 3.7 Disc brake ECO Disc 3.8 Disc and drum brake: operating instructions
<h2>4 SUSPENSION SYSTEMS</h2>	<ul style="list-style-type: none"> 4.1 Air suspension ECO Air 4.2 Air suspensions Airlight II and SL 	<ul style="list-style-type: none"> 4.3 Mechanical suspension ECO Cargo VB 4.4 Mechanical suspension ECO Cargo W 	

Table of contents

1 Program Running gears for commercial vehicles.....	8	2 Axles	41
1.1 Overview	9	2.1 Identification.....	42
1.2 Running gears	10	2.1.1 Type plate of the axles	42
1.2.1 Drum brake axles	10	2.1.2 Important type designations for axles	43
1.2.2 Disc brake axles	11	2.1.3 Important type designations for air suspension units	45
1.2.3 Axles with air suspension	12	2.1.4 Important type designations for mechanical suspension units	48
1.2.4 Rigid and self-steering axles with air suspension	13	2.1.5 Explanation of item numbers	50
1.2.5 Forced steering axles	14	2.2 Track width	51
1.2.6 Axles with mechanical suspension	15	2.2.1 BPW declaration	51
1.2.7 Stub axles	26	2.2.2 Twin wheels	52
1.2.8 Swing axles	27	2.3 Wheel connections.....	53
1.2.9 Turntables	29	2.3.1 General	53
1.3 Recommendation for use	30	2.3.2 Centering	55
1.3.1 Axles and air suspensions (Europe)	30	2.3.3 Aluminium wheels	57
1.3.2 Axle loads and speed	32	2.3.4 Standard axles ECO Plus 3	58
1.3.3 Wheel brakes	33	2.4 Self-steering axles	60
1.3.4 Brake system	35	2.4.1 Reasons for use; VECTO Bonus	60
1.3.5 Offset for single wheels (disc brake)	36	2.4.2 Functional principle of undulated pressure disc, expert opinion	61
1.3.6 Benefits of Air suspension compared to Mechanical suspension	37	2.4.3 Reversing	62
1.4 Website / Configurator / Further products	38	2.4.4 Auxiliary steering with ARC (Active Reverse Control)	63
1.4.1 bpw.de	38	2.4.5 Steering angle and limitation	64
1.4.2 Configurator	39	2.4.6 Steering damper	65
1.4.3 Landing gear	40	2.4.7 Installation angular position at nominal ride height	66
		2.4.8 Optimized installation in the unit (3D Trailing arm, Channel crossmember)	67

2.5 Forced steering axles	68	3.2 Brake cylinder.....	96
2.5.1 Advantages and operating principle	68	3.2.1 Functions and features	96
2.5.2 Variants of important details	69	3.2.2 Versions	99
2.5.3 Installation of angular position at nominal ride height	70	3.2.3 Test reports	100
2.6 Stub axles	71	3.3 ABS sensor, exciter ring	101
2.6.1 Application, features, advantages	71	3.3.1 Versions	101
2.7 Swing axles.....	72	3.3.2 Retrofit ABS sensor	102
2.7.1 Functional principle	72	3.3.3 EBS installation and number of axles to be sensed	103
2.7.2 Construction	73	3.4 Base plates for drum brake axles.....	104
2.7.3 Single tyres, offset and track width	74	3.4.1 General	104
2.7.4 Twin wheels and track width	75	3.4.2 Versions	105
2.8 Additional equipment.....	76	3.5 Slack adjuster ECO-Master.....	109
2.8.1 Odometer ECOMETER	76	3.6 Drum brake ECO Drum.....	111
2.8.2 Tyre pressure monitoring system TPMS	78	3.6.1 Transport and storage	111
2.8.3 Tyre pressure control system AirSave	79	3.6.2 Installation and adjustment *	112
2.8.4 Electrohydraulic auxiliary steering Active Reverse Control (ARC)	80	3.7 Disc brake ECO Disc.....	116
2.8.5 Generator axle ePower	82	3.7.1 Transport and storage	116
2.8.6 Lightweight aluminum hub	86	3.7.2 Installation	117
2.8.7 iC Plus running gear	87	3.7.3 Brake pad wear sensing	120
3 Brakes	88	3.7.4 Dust cover	126
3.1 Design, test reports, calculation.....	89	3.8 Disc and drum brake: operating instructions.....	128
3.1.1 Brake system design	89		
3.1.2 Brake data disc brakes	91		
3.1.3 Brake data drum brakes	92		
3.1.4 Test reports, expert opinions	93		
3.1.5 Brake calculation data sheet	95		

4 Suspension systems	131		
4.1 Air suspension ECO Air	132		
4.1.1 Notes, design, system kit	132		
4.1.2 Force calculations	137		
4.1.3 Installation and welding specifications of hanger brackets	141		
4.1.4 Hanger bracket gusseting	146		
4.1.5 Spring bolt bearing	150		
4.1.6 Air bags	151		
4.1.7 Shock absorber	157		
4.1.8 Alignment	159		
4.1.9 Air suspension installation	162		
4.1.10 Axle lifts; VECTO Bonus	170		
4.1.11 Tightening torques	176		
4.1.12 Surface treatment	177		
4.1.13 Characteristic curves and data sheets on My BPW	178		
4.2 Air suspensions Airlight II and SL.....	182		
4.2.1 Notes and design	182		
4.2.2 Force calculations	185		
4.2.3 Installation and welding specifications of hanger brackets	189		
4.2.4 Hanger brackets, channel crossmembers, gusseting	193		
4.2.5 Trailing arm and spring bolt bearing	203		
4.2.6 Axle beam welding and connection	206		
4.2.7 Air bags	208		
4.2.8 Shock absorbers	215		
4.2.9 Alignment	218		
4.2.10 Air suspension installation	223		
4.2.11 Axle lifts	231		
4.2.12 U-stabilizer	238		
4.2.13 Tightening torques	239		
4.2.14 Surface treatment	240		
4.2.15 Characteristic curves and data sheets on My BPW	241		
4.3 Mechanical suspension ECO Cargo VB.....	244		
4.3.1 Notes, features, series	244		
4.3.2 Function, ABS, axle loads	247		
4.3.3 Axle beam welding guidelines	250		
4.3.4 Installation and bracing	251		
4.3.5 U-stabilizer	257		
4.3.6 Alignment	258		
4.3.7 Tightening torques	263		
4.4 Mechanical suspension ECO Cargo W	264		
4.4.1 Features and series	264		
4.4.2 Installation	266		
4.4.3 Alignment	267		

Editorial

This AxleGuide represents an interactive design manual with catalog function on BPW running gears for commercial vehicles. The document integrates the most important technical information previously only available separately, as well as installation instructions. It explains functional relationships using newly created overviews and contains links to data sheets, test protocols and further information.

The AxleGuide is primarily aimed at vehicle manufacturers and their employees in development, design, production, purchasing and sales. But vehicle operators or workshops, as well as those involved in training or further education, can also benefit from this.

Additional documentation can still be found at www.bpw.de. Warranty documents, maintenance and workshop manuals or spare parts documentation, for example, also remain there and are therefore not integrated into the AxleGuide. These must be observed for further information such as safety instructions and tightening torques for maintenance or repair.

The recommendations described reflect the many years of experience of BPW application engineering. In special cases, please get in touch with your BPW contact person.

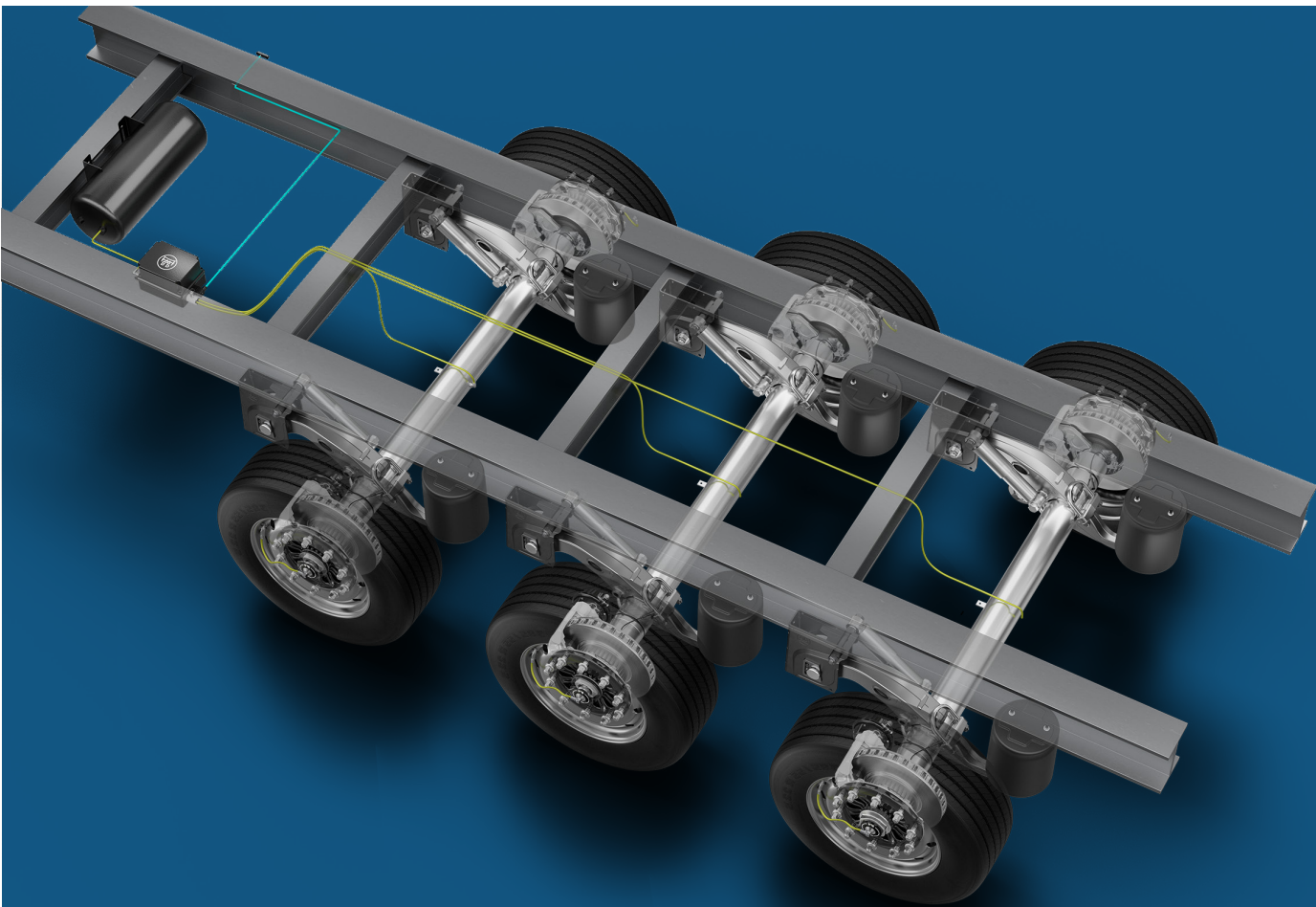

1

PROGRAM RUNNING GEARS FOR COMMERCIAL VEHICLES

- 1.1 Overview
- 1.2 Running gears
- 1.3 Recommendation for use
- 1.4 Website / Configurator / Further products

1.1 Overview

Air suspension units ECO Air, SL, ALII

Rigid, self-steering or forced-steering

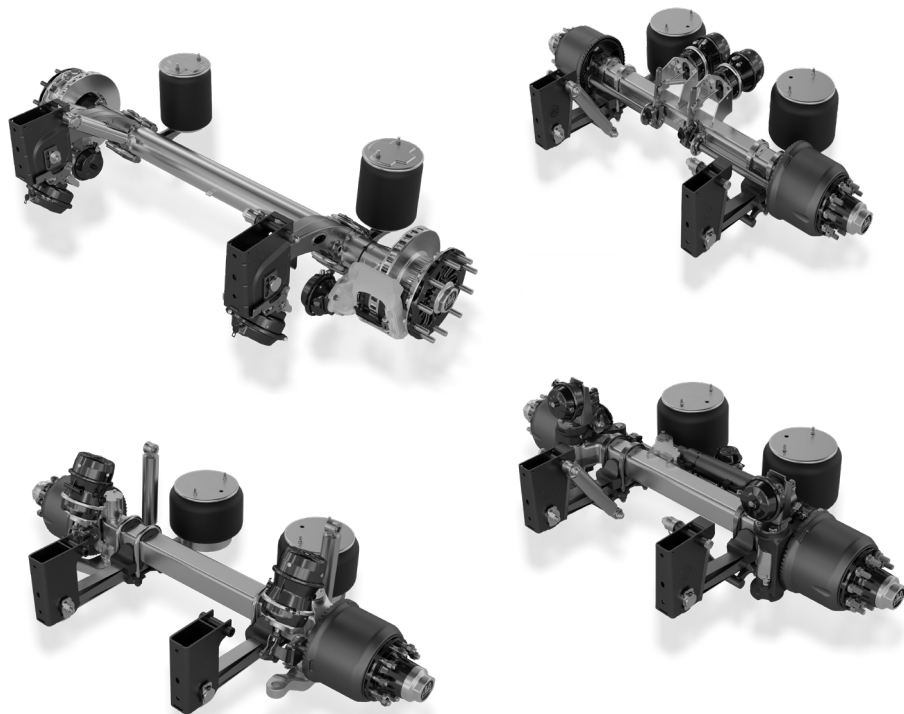

Mechanically suspended units ECO Cargo VB, ECO Cargo W, stub axles and swing axles

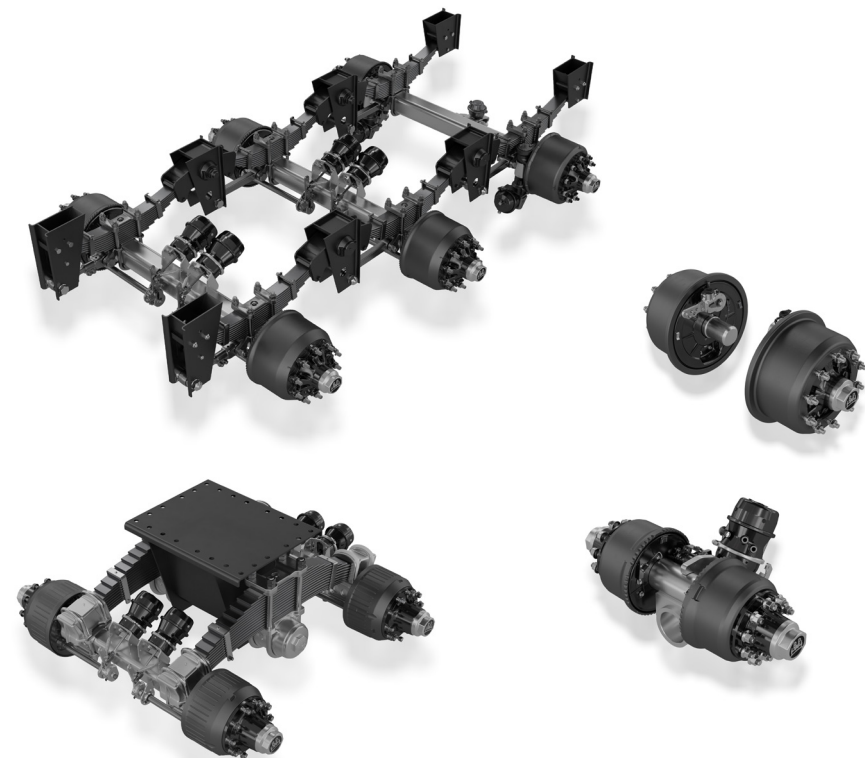

1.2 Running gears

1.2.1 Drum brake axles



Series axle Series brake	N SN 3010	N SN 3012	N SN 3015	N SN 3020	K SN 3620	H, M SN 4212	R, H, M SN 4218	H, M SN 4220	M SN 5020
Drum dimension Diameter x brake shoe width	300 x 100	300 x 120	300 x 150	300 x 200	360 x 200	420 x 120	420 x 180	420 x 200	500 x 200
Typical axle load	5.5t	6 t	7t	12t	12t	6.5t	9 t / 10 t	12t	30t
Suitable for wheels (Single wheels with offset 0 or twin wheels) Rim diameter	9"-12" 15"-19.5"	15" - 17.5" 19.5"	15"-17.5" 19.5"	17.5" 19.5"	19.5" 22.5"	22.5"	22.5"	20" 22.5"	24"
Typical wheel con- nection Pitch circle / number of wheel studs	Ø 155 / 6 Ø 205 / 6	Ø 225 / 10	Ø 275 / 8 Ø 225 / 10	Ø 225 / 10	Ø 275 / 8 Ø 335 / 10 Ø 225 / 10	Ø 335 / 10	Ø 335 / 10	Ø 335 / 10	Ø 425 / 24
Axle beam Square or Round	Round 101.6	Square 90 Square 120	Square 120 Round 127 *	Square 120	Square 120	Square 90 Square 120	Square 120 Square 150 Round 146	Square 120 Square 150	Square 150

*only for swing axles

SN = S-Cam brake, air operated

1.2.2 Disc brake axles

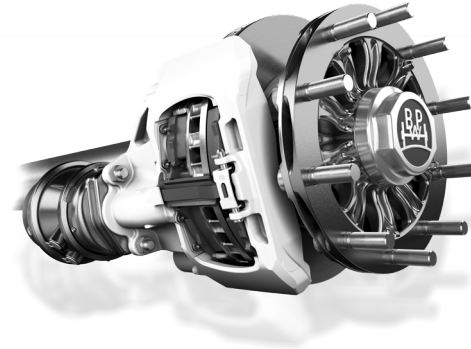

Series axle Series brake	SN SB 3307	SKR, SKH TS2 3709	SR, SH TS2 4309	SH TSB 4312
Brake disc dimension Diameter x thickness	Ø 330 x 34	Ø 374 x 45	Ø 430 x 45	Ø 430 x 45
Typical axle load	5.5 t	9 t 10 t (19.5" only)	9 t 10 t	12 t
Suitable for wheels Offset Rim diameter	ET 0 or twin 17.5"	ET 0 or twin; ET 120 at 9 t 19.5" / 22.5"	ET 0 or twin; ET 120 at 9 t 22.5"	ET 0 or twin 22.5"
Wheel connection Pitch circle / number of wheel studs	Ø 205 / 6	Ø 335 / 10 Ø 275 / 8	Ø 335 / 10	Ø 335 / 10
Axle beam Square or Round	Round 101.6	Square 120 Round 146	Square 120 Round 146	Square 150

Principle floating caliper, air operated

TSB = Trailer disc brake 1st generation

TS2 = Trailer disc brake 2nd generation

SB = Disc brake

1.2.3 Axles with air suspension | Overview

				
Air suspension series	SL / Light	ECO Air (EA)	Airlight II (ALII)	SL / HEAVY
Use	light	Standard	Special requirement	Heavy Duty
Type	Trailing arm width 70 mm	Cast trailing arm, Large volume rubber bush	Trailing arm width 70 mm	Trailing arm width 100 mm
Axle load Wheels	4 - 5.5 t Single and twin	9 t Single	9 - 12 t Single and twin	12 - 14 t Single and twin
Axle beam Axle clamping	Round 101.6 mm Welded spring seats	Round 146 mm Clamped spring seats	Round 146 mm, Square 120 mm Clamped or welded spring seats	Square 150 mm Welded spring seats
Compatible with steering axles	No	No	Yes	Yes
Brake	Drum or disc			

1.2.4 Rigid and self-steering axles with air suspension

The data sheets are available in the download area on My BPW. More detailed explanations of the tables:

[see chapter 4.1.13](#)

[see chapter 4.2.15](#)

Airlight II
Air suspension axles with disc brake TS2 3709 (9 t)
Series ALO, air bag 30 / 30K

Ride height 390 - 565 mm for trailer and semi-trailer

AL II - TS2.0 Sheet 1

ECO Air
Air suspension axles with drum brake SN 4218

Ride height 250 - 510 mm Long stroke air bags

EA Sheet 2c

Ride height 205 - 510 mm Standard air bags

EA Sheet 1a

Series, main features	Data sheet
ECO Air up to 9 t with drum and disc brake, round axle beam 146 mm	EA
Airlight II up to 12 t with drum brake and square axle beam 120 mm	AL II - SN.0
Airlight II up to 10 t with disc brake and square axle beam 120 mm	AL II - TS2.0
Airlight II up to 9 t as ALO and ALM, with drum brake and round axle beam 146 mm	AL II - SN.0-R
Airlight II up to 9 t as ALO and ALM, with disc brake and round axle beam 146 mm	AL II - TS2.0-R
SL up to 12 t with drum brake, square axle beam 150 mm	SL - SN.01
SL up to 14 t with drum brake, square axle beam 150 mm	On request
SL up to 12 t with disc brake, square axle beam 150 mm	SL - SB.01
SL up to 5.5 t with disc and drum brake, round axle beam 101.6 mm	TD 3030.0

SN = S-cam brake (= drum brake)

TS2 = 2nd generation trailer disc brake

SB = disc brake

1.2.5 Forced steering axles | L series, 9...14 t axle load

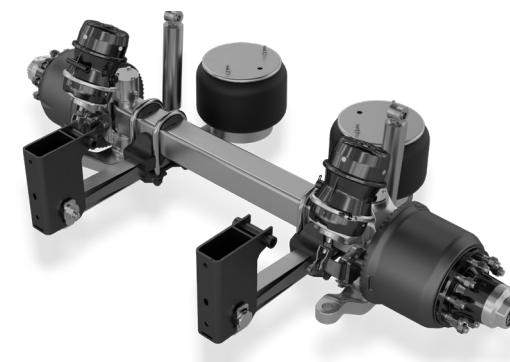

Type ¹⁾	Permissible axle load up to 105 km/h (kg)	Brake	Tyre	Wheels	Wheel connection		max. steering angle (°)
					Wheel stud	∅ H / K (mm)	
NHZFL	9,000	SN 3020	245/70 R17.5	17.5 x 6.75	10 x M22 x 1.5	225 / 175.8 ²⁾	45
NHZFL	12,000	SN 3020	245/70 R17.5	17.5 x 6.75	10 x M22 x 1.5	225 / 175.8	45
KMSFL	12,000	SN 3620	445/45 R19.5	19.5 x 14.00	8 x M22 x 1.5	275 / 220.8	45
KMZFL	12,000	SN 3620	285/70 R19.5	19.5 x 8.25	8 x M22 x 1.5	275 / 220.8	45
HSFL	9,000	SN 4218	385/65 R22.5	22.5 x 11.75	10 x M22 x 1.5	335 / 280.8	40
MSFL	12,000	SN 4220	445/65 R22.5	22.5 x 14.00	10 x M22 x 1.5	335 / 280.8	40
MZFL	12,000	SN 4220	275/70 R22.5	22.5 x 8.25	10 x M22 x 1.5	335 / 280.8	40
MSFL	14,000	SN 4220	12 R22.5	22.5 x 8.25	10 x M22 x 1.5	335 / 280.8	35

¹⁾ With lightweight hollow axle beams available in conjunction with BPW AL II air suspension and max. 1240 mm track - spring center differential

²⁾ H = pitch circle; K = center hole

1.2.6 Axles with mechanical suspension | Overview

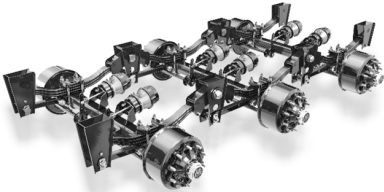
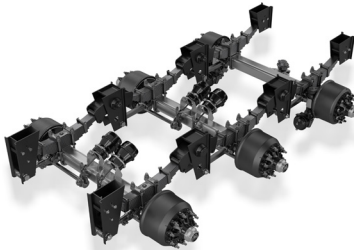
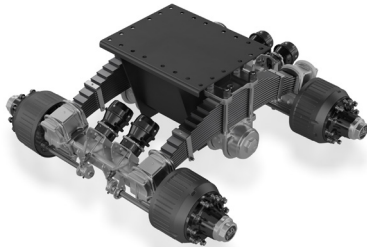
				
Series mechanical suspension	ECO Cargo VB(T)	ECO Cargo VB (M/ME)	ECO Cargo VB(T) (HD/HDE)	ECO Cargo W
Use	light	Standard (M series)	Heavy Duty (HD series)	Heavy Duty (HD)
Federtyp	Parabolic springs 80 mm wide (T) = Springs underslung	Parabolic springs or multi-leaf springs 76 mm wide	Multi-leaf springs 100 mm wide (T) = Springs underslung	Multi-leaf springs 90 or 120 mm wide
Axle load Wheels	5.5t Single and twin	9 - 12 t Single and twin	12 - 20 t Twin	10 - 20 t Twin
Axle beam Spring seat arrangement	Round 101.6 mm Welded spring pads	Square 120 mm, Square 150 mm Welded spring pads	Square 150 mm Welded spring pads	Square 150 mm Welded spring pads
Compatible with steering axles	No	No	Yes	No
Brake	Brake drum			
Bearing equalizer	Rubber bush	M: Rubber bush ME: Bronze bush	HD: Rubber bush HDE: Bronze bush	-

1.2.6 Axles with mechanical suspension | ECO Cargo VB(T), 5.5 t axle load

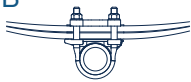
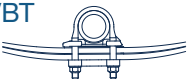
Type	Axle load (kg)	Wheelbase (mm)	Leaf spring width (mm)	Leaf spring thickness (mm)	Unit type	Ride height (FH)	
						laden (mm)	unladen (mm)
VB 	5,500	990	80	2 x 18	Single axle unit	254	275
					Tandem axle unit	256	277
VBT 					Single axle unit	81	102
					Tandem axle unit	83	104

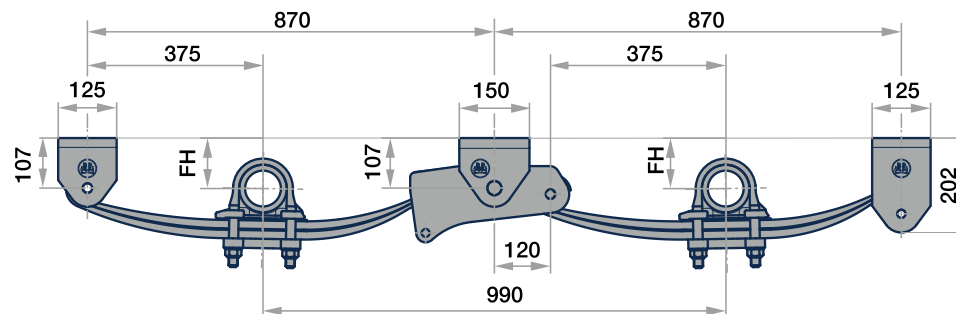

1.2.6 Axles with mechanical suspension | ECO Cargo VB, 9 - 12 t Axle load

The illustration shows an example of a three-axle unit with the main dimensions for a preselection. The table of common designs on the following pages refers to this.

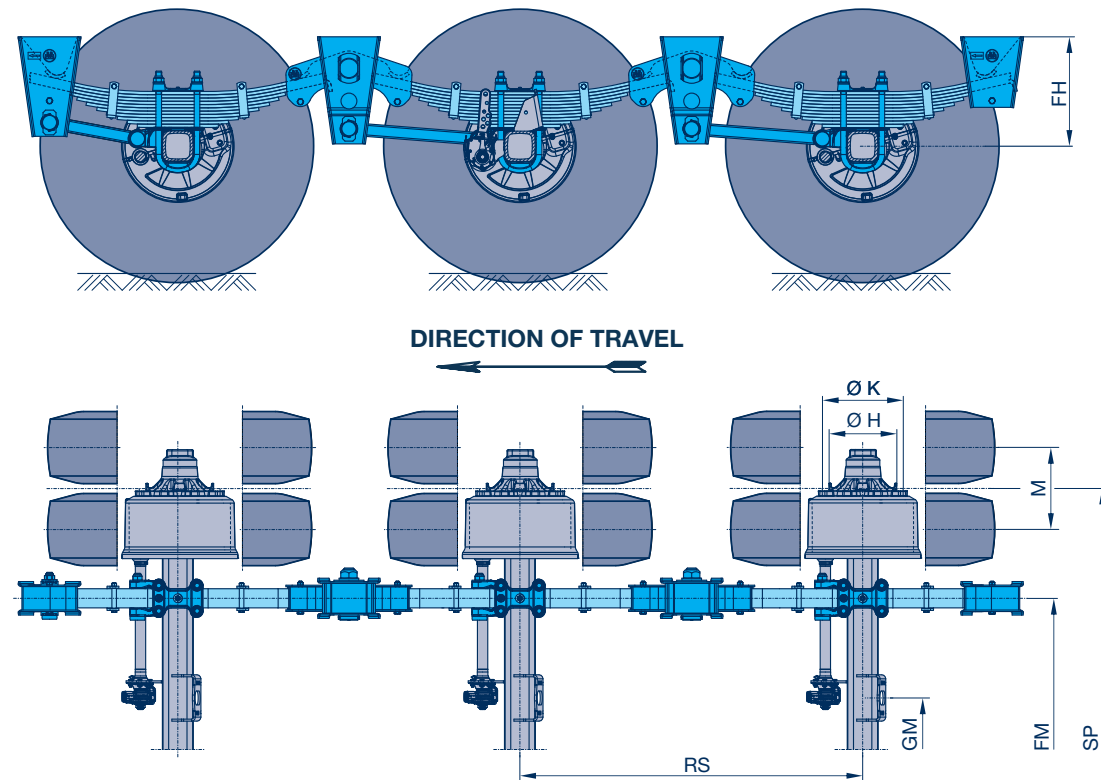

1.2.6 Axles with mechanical suspension | ECO Cargo VB, 9 - 12 t Axle load

No.	Type	Single axle	2-axle unit	3-axle unit	Axle beam	S-Cam brake	Track (mm)	Spring centre (FM) (mm)	Brake chamber bracket centre (mm)	Example tyre ²⁾ (mm)	M = Rim center distance ET = Offset
1	HSFVB	9010	2/9010	---	120	SN 4218	2,040	1,300	525	385/65 R22.5	ET 0
2	HSFVB	9010	2/9010	3/9010	120	SN 4218	2,040	1,300	525	385/65 R22.5	ET 0
3	HSFVB	9010	2/9010	3/9010	120	SN 4218	2,040	1,300	525	385/65 R22.5	ET 0
4	HSFVB	9010	2/9010	3/9010	120	SN 4218	2,040	1,300	525	385/65 R22.5	ET 0
5	HSFVB	9010	2/9010	3/9010	120	SN 4218	2,010	1,200	495	385/65 R22.5	ET 0
6	HZFVB	9010	2/9010	3/9010	120	SN 4218	1,820	900	335	275/70 R22.5	M = 320
7	NHZFVB	12010	2/12010	---	120	SN 3020	1,830	980	239	245/70 R17.5	M = 290
8	NHZFVB	12010	2/12010	3/12010	120	SN 3020	1,950	1,100	243	245/70 R17.5	M = 290
9	HSFVB	12010	2/12010	3/12010	150	SN 4220	2,040	1,300	365	445/65 R22.5	ET 0
10	HSFVB	12010	2/12010	3/12010	150	SN 4220	2,040	1,300	365	445/65 R22.5	ET 0
11	HZFVB ¹⁾	12010	2/12010	3/12010	150	SN 4220	1,820	900	261	295/80 R22.5	M = 330
12	HSFVB	12010	2/12010	3/12010	150	SN 4220	2,040	1,300	365	445/65 R22.5	ET 0
13	HSFVB	12010	2/12010	3/12010	150	SN 4220	2,000	1,200	325	445/65 R22.5	ET 0
14	HSFVB	12010	2/12010	3/12010	150	SN 4220	2,040	1,300	365	445/65 R22.5	ET 0
15	HSFVB	12010	2/12010	3/12010	150	SN 4220	2,000	1,200	325	445/65 R22.5	ET 0
16	HZFVB ¹⁾	12010	2/12010	3/12010	150	SN 4220	1,820	900	261	295/80 R22.5	M = 330
17	HZFVB ¹⁾	12010	2/12010	3/12010	150	SN 4220	1,850	980	241	295/80 R22.5	M = 330
18	HZFVB ¹⁾	---	2/12010	3/12010	150	SN 4220	1,820	900	261	295/80 R22.5	M = 330
19	HZFVB ¹⁾	---	2/12010	3/12010	150	SN 4220	1,850	980	241	295/80 R22.5	M = 330

P. 19

¹⁾ Also available as Trilex version: Type designation HIZVB ... Track widths vary according to tyre size and spacer ring.

²⁾ Observe any specifications from tyre manufacturers for load index and dimensions.

1.2.6 Axles with mechanical suspension | ECO Cargo VB, 9 - 12 t Axle load

	No.	Total construction width over tyres (mm)	Wheel connection		Wheelbase (mm)	Hanger version	Ride height (mm)				Unit weight ⁴⁾ (kg)		
			Wheel stud	Diameter H / K (mm)			with multi-leaf spring		with parabolic spring		Single axle	2-axle unit	3-axle unit
							laden ³⁾	unladen	laden ³⁾	unladen			
	1	2,435	10 x M22 x 1.5	280.8 / 335	1,310	low	---	---	232	256	427	896	---
	2	2,435	10 x M22 x 1.5	280.8 / 335	1,310	moderate	---	---	268	292	430	891	1,353
	3	2,435	10 x M22 x 1.5	280.8 / 335	1,360	moderate	337	379	---	---	489	1,009	1,530
	4	2,435	10 x M22 x 1.5	280.8 / 335	1,360	high	367	409	---	---	494	1,015	1,536
	5	2,405	10 x M22 x 1.5	280.8 / 335	1,360	high	367	409	---	---	493	1,013	1,533
	6	2,432	10 x M22 x 1.5	280.8 / 335	1,360	high	367	409	---	---	491	1,009	1,527
	7	2,365	10 x M22 x 1.5	175.8 / 225	1,310	low	---	---	232	256	429	900	---
	8	2,485	10 x M22 x 1.5	175.8 / 225	1,310	moderate	---	---	268	292	445	921	1,368
	9	2,505	10 x M22 x 1.5	280.8 / 335	1,310	high	---	---	313	337	502	1,031	1,560
	10	2,505	10 x M22 x 1.5	280.8 / 335	1,360	high	---	---	388	412	529	1,084	1,640
	11	2,465	10 x M22 x 1.5	280.8 / 335	1,360	high	---	---	388	412	530	1,086	1,643
	12	2,505	10 x M22 x 1.5	280.8 / 335	1,360	moderate	375	417	---	---	578	1,189	1,799
	13	2,465	10 x M22 x 1.5	280.8 / 335	1,360	moderate	375	417	---	---	577	1,187	1,796
	14	2,505	10 x M22 x 1.5	280.8 / 335	1,360	high	405	447	---	---	584	1,194	1,805
	15	2,465	10 x M22 x 1.5	280.8 / 335	1,360	high	405	447	---	---	583	1,192	1,802
	16	2,465	10 x M22 x 1.5	280.8 / 335	1,360	high	405	447	---	---	585	1,196	1,808
	17	2,495	10 x M22 x 1.5	280.8 / 335	1,360	high	405	447	---	---	592	1,210	1,829
	18	2,465	10 x M22 x 1.5	280.8 / 335	1,820	high	405	447	---	---	---	1,232	1,879
	19	2,495	10 x M22 x 1.5	280.8 / 335	1,820	high	405	447	---	---	---	1,246	1,900

For higher axle loads, choose the tried and tested ECO Cargo VB HD. Please get in touch for more information.

Please consult with BPW about offers for 4-axle combinations.

All multi-axle versions are available with rubber or bronze bushings on the equalising beam.

³⁾ For axle units, make space for dynamic travel and equalizing movement.

⁴⁾ Weight without wheels and tyres: Weight deviations are within permitted DIN tolerances for respective production processes.

1.2.6 Axles with mechanical suspension | ECO Cargo VB HD, 14 - 20 t Axle load

The illustration shows an example of a three-axle unit with the main dimensions for a preselection. The table of common designs on the following pages refers to this.

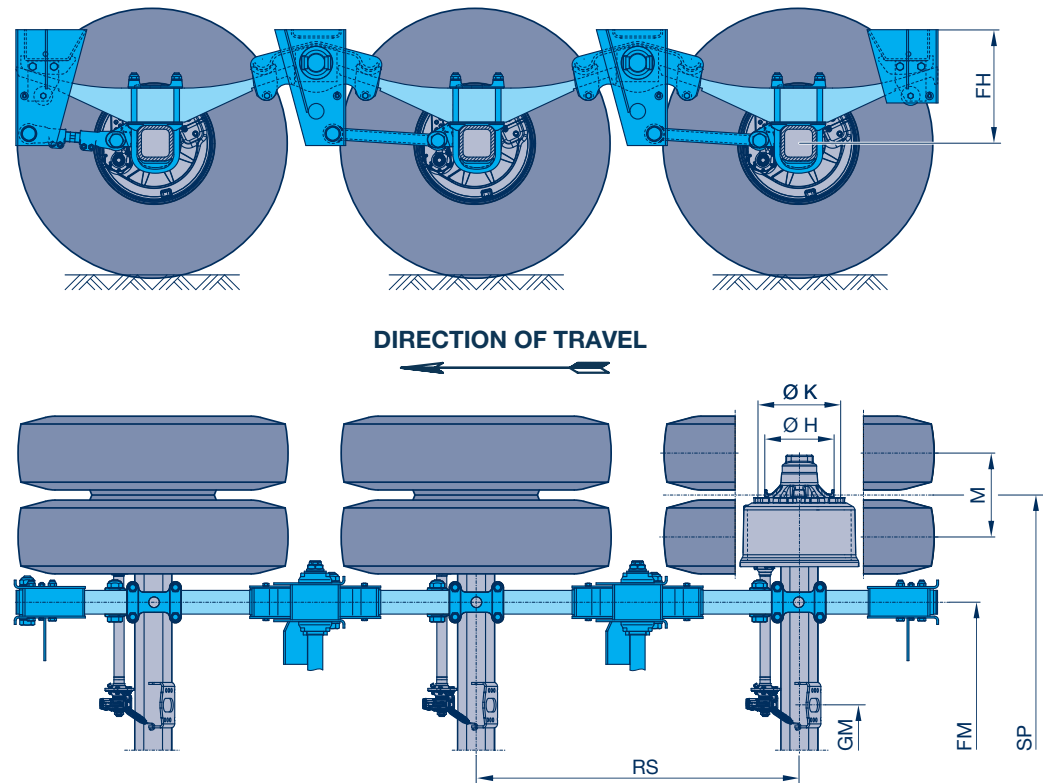

1.2.6 Axles with mechanical suspension | ECO Cargo VB HD, 14 - 20 t Axle load

No.	Type ¹⁾	Single axle	2-axle unit	3-axle unit	Version ²⁾	S-Cam brake	Track (SP) (mm)	Spring centre (FM) (mm)	Brake chamber bracket centre (mm)	Wheelbase (RS) (mm)
1	HZFBV		2/14010	3/14010	HD/HDE	SN 4220	1,820	900	266	1,360
2	HZFBV		2/14010	3/14010	HD/HDE	SN 4220	1,820	900	266	1,410
3	HZFBV	14,010	2/14010	3/14010	HD/HDE	SN 4220	1,820	900	266	1,500
4	HZMBV		2/16010	3/16010	HDE	SN 4220	1,820	900	261	1,360
5	HZMBV		2/16010	3/16010	HDE	SN 4220	1,950	900	281	1,410
6	HZMBV		2/16010	3/16010	HDE	SN 4220	2,250	1,200	505	1,500
7	HZMBV	16,010	2/16010	3/16010	HDE	SN 4220	1,820	900	261	1,500
8	HZMBV	18,010	2/18010	3/18010	HDE	SN 4220	1,820	900	261	1,500
9	HZMBV	18,010	2/18010	3/18010	HDE	SN 4220	1,950	900	281	1,500
10	HZMBV	18,010	2/18010	3/18010	HDE	SN 4220	2,320	1,200	407	1,500
11	HZMBV	20,010	2/20010	3/20010	HDE	SN 4220	1,950	900	278	1,500
12	HZMBV	20,010	2/20010	3/20010	HDE	SN 4220	2,200	1,100	354	1,500
13	HZMBV	20,010	2/20010	3/20010	HDE	SN 4220	2,400	1,300	554	1,500

P. 22

¹⁾ Also available as Trilex version: Type designation HIZVB ... Track widths vary according to tyre size and spacer ring.

²⁾ HD: Swing arm bearing in rubber-steel bushings / HDE: Swing arm bearing in bronze bushings.

1.2.6 Axles with mechanical suspension | ECO Cargo VB HD, 14 - 20 t Axle load

	No.	Example tyre ³⁾ (mm)	M = Rim center distance	Total construction width over tyres (mm)	Wheel connection		Ride height (FH) (mm)		Unit weights (kg) ⁵⁾		
					Wheel stud	Ø H / K (mm)	laden ⁴⁾	unladen	Single axle	2-axle unit	3-axle unit
	1	12 R20	M = 350	2,496	10 x M22 x 1.5	280.8 / 335	430	475		1,527	2,300
	2	12 R24	M = 360	2,509	10 x M22 x 1.5	280.8 / 335	435	480		1,548	2,331
	3	12 R24	M = 360	2,509	10 x M22 x 1.5	280.8 / 335	455	500	814	1,592	2,432
	4	12 R20	M = 350	2,496	10 x M22 x 1.5	280.8 / 335	475	500		1,640	2,469
	5	12 R24	M = 360	2,639	10 x M22 x 1.5	280.8 / 335	460	495		1,678	2,525
	6	12 R24	M = 360	2,939	10 x M22 x 1.5	280.8 / 335	490	530		1,767	2,659
P.21	7	12 R24	M = 360	2,509	10 x M22 x 1.5	280.8 / 335	490	530	864	1,715	2,581
	8	12 R24	M = 360	2,496	10 x M22 x 1.5	280.8 / 335	460	480		1,735	2,612
	9	14 R20	M = 428	2,776	10 x M22 x 1.5	280.8 / 335	460	480		1,757	2,645
	10	14 R20	M = 428	3,146	10 x M22 x 1.5	280.8 / 335	460	480	940	1,817	2,735
	11	14 R20	M = 428	2,776	10 x M24 x 1.5	280.8 / 335	455	480		1,885	2,837
	12	14 R20	M = 428	3,026	10 x M24 x 1.5	280.8 / 335	455	480		1,931	2,906
	13	14 R20	M = 428	3,226	10 x M24 x 1.5	280.8 / 335	455	480	1,015	1,967	2,960

³⁾ Observe any specifications from tyre manufacturers for load index and dimensions.

⁴⁾ For axle units, make space for dynamic travel and equalizing movement.

⁵⁾ Weight without wheels and tyres; Weight deviations are within the permissible DIN tolerances for the respective manufacturing process.

1.2.6 Axles with mechanical suspension | ECO Cargo W, 20 - 40 t Unit load

The illustrations show exemplarily two units, once with high support block (left) and once with low support block (right), with the main dimensions for a preselection. The table of common designs on the following pages refers to this.

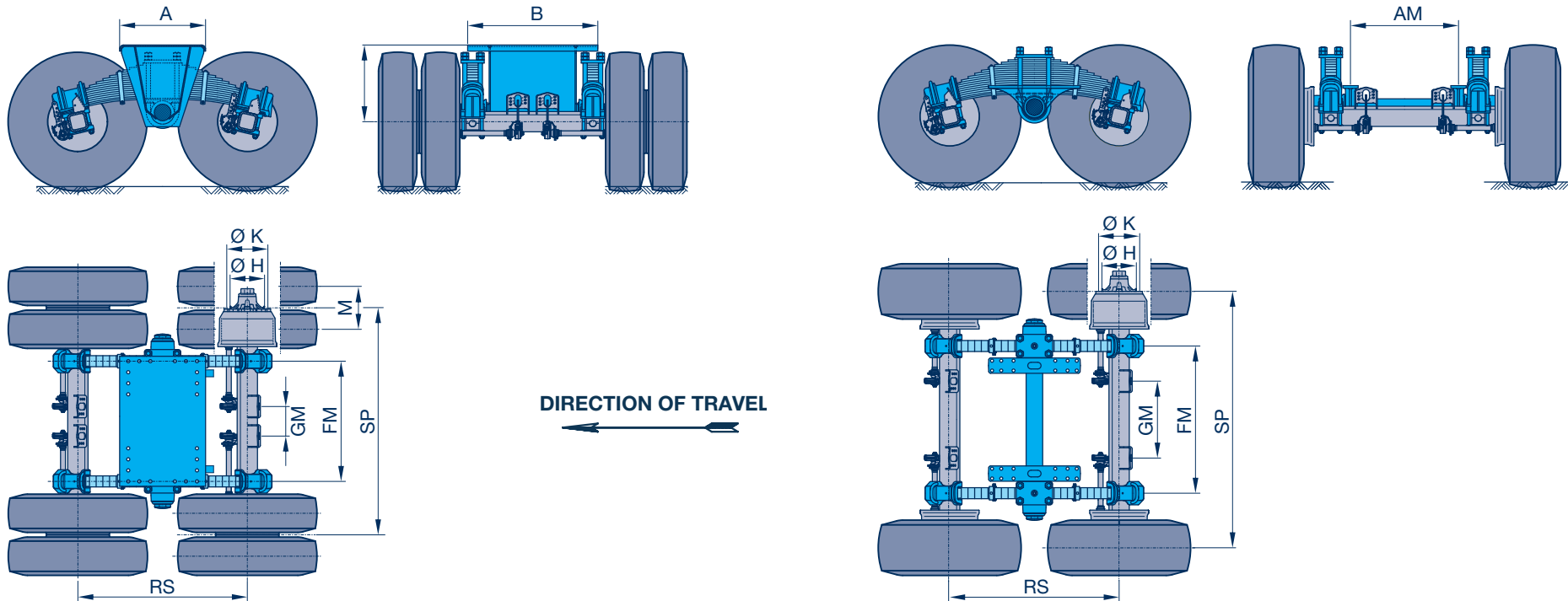

1.2.6 Axles with mechanical suspension | ECO Cargo W, 20 - 40 t Unit load

No.	Type	Axle unit loads up to 105 km/h (kg)	S-Cam brake	Track (mm)	Spring centre (FM) (mm)	Brake chamber bracket centre (mm)	Support centre (mm)	High support (A x B x H) (mm)	Wheelbase (RS) (mm)
1	HZFW 2/10010	20,000	SN 4220	1,820	980	261	660		1,400
2	HZFW 2/10010	20,000	SN 4220	1,820	980	261		700 x 1,060 x 550	1,400
3	HZFW 2/12010 B ¹⁾	24,000	SN 4220	1,820	980	261	660		1,400
4	HZFW 2/12010 B ¹⁾	24,000	SN 4220	1,820	980	260		700 x 1,060 x 600	1,400
5	HZFW 2/12010 C ²⁾	24,000	SN 4220	1,820	980	261	660		1,500
6	HZFW 2/12010 C ²⁾	24,000	SN 4220	1,820	980	261		700 x 1,060 x 600	1,500
7	HZ(M)W 2/14010-1	28,000	SN 4220	1,820	900	266	520		1,500
8	HZ(M)W 2/14010-1	28,000	SN 4220	1,820	900	266		800 x 980 x 600	1,500
9	HZ(M)W 2/14010-1	28,000	SN 4220	1,920	900	290	520		1,650
10	HZ(M)W 2/14010-1	28,000	SN 4220	1,920	900	290		800 x 980 x 600	1,650
11	HZMW 2/16010	32,000	SN 4220	1,800	900	241	520		1,550
12	HZMW 2/16010	32,000	SN 4220	1,800	900	241		800 x 980 x 600	1,550
13	HZMW 2/16010	32,000	SN 4220	2,150	1,150	367	770		1,550
14	HZMW 2/16010	32,000	SN 4220	2,150	1,150	367		800 x 1,230 x 600	1,550
15	HZMW 2/18010	36,000	SN 4220	1,800	900	241	520		1,550
16	HZMW 2/18010	36,000	SN 4220	1,800	900	241		800 x 980 x 600	1,550
17	HZMW 2/18010	36,000	SN 4220	2,150	1,150	367		800 x 1,230 x 600	1,550
18	HZMW 2/18010	36,000	SN 4220	2,320	1,150	407		800 x 1,230 x 700	1,650
19	HZMW 2/20010	40,000	SN 4220	1,950	900	278		800 x 980 x 700	1,550
20	HZMW 2/20010	40,000	SN 4220	2,200	1,150	354		800 x 1,230 x 700	1,550

P. 25

Trilex version also available.

¹⁾Version for heavy-duty use.²⁾Version for road use.

1.2.6 Axles with mechanical suspension | ECO Cargo W, 20 - 40 t Unit load

No.	Ride height (mm)		Wheel connection		Example tyre ³⁾	Rim center distance (M)	Total construction width over tyres (mm)	Unit weight (kg) ⁴⁾
	laden	unladen	Wheel stud	Ø H / K (mm)				
1	213	253	10 x M22 x 1.5	280.8 / 335	11 R20	M = 348	2,482	1,650
2	588	628	10 x M22 x 1.5	280.8 / 335	11 R20	M = 348	2,482	1,840
3	213	253	10 x M22 x 1.5	280.8 / 335	12 R20	M = 350	2,496	1,710
4	638	678	10 x M22 x 1.5	280.8 / 335	12 R20	M = 350	2,496	1,862
5	207	253	10 x M22 x 1.5	280.8 / 335	12 R24	M = 360	2,509	1,650
6	630	675	10 x M22 x 1.5	280.8 / 335	12 R24	M = 360	2,509	1,820
7	214	259	10 x M22 x 1.5	280.8 / 335	12 R20	M = 350	2,496	2,126
8	614	659	10 x M22 x 1.5	280.8 / 335	12 R20	M = 350	2,496	2,202
9	209	262	10 x M22 x 1.5	280.8 / 335	14 R20	M = 428	2,746	2,272
10	609	662	10 x M22 x 1.5	280.8 / 335	14 R20	M = 428	2,746	2,345
11	210	257	10 x M22 x 1.5	280.8 / 335	12 R24	M = 350	2,489	2,210
12	610	657	10 x M22 x 1.5	280.8 / 335	12 R24	M = 350	2,489	2,309
13	210	257	10 x M22 x 1.5	280.8 / 335	12 R24	M = 350	2,839	2,329
14	610	657	10 x M22 x 1.5	280.8 / 335	12 R24	M = 350	2,839	2,412
15	217	259	10 x M22 x 1.5	280.8 / 335	12 R24	M = 350	2,489	2,256
16	617	659	10 x M22 x 1.5	280.8 / 335	12 R24	M = 350	2,489	2,440
17	617	659	10 x M22 x 1.5	280.8 / 335	14 R20	M = 428	2,976	2,542
18	709	762	10 x M22 x 1.5	280.8 / 335	14 R24	M = 430	3,150	2,911
19	717	759	10 x M24 x 1.5	280.8 / 335	14 R20	M = 428	2,776	2,710
20	717	759	10 x M24 x 1.5	280.8 / 335	14 R20	M = 428	3,026	2,943

³⁾ Observe any specifications from tyre manufacturers for load index and dimensions.

⁴⁾ Weight without wheels and tyres: Weight deviations are within permitted DIN tolerances for respective production processes.

1.2.7 Stub axles | 6 - 60 t axle load

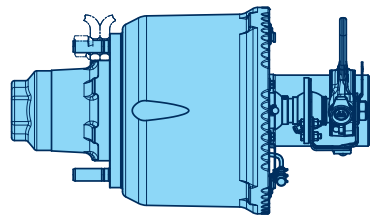
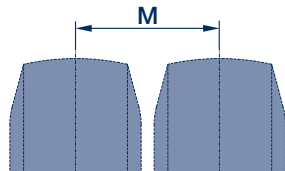
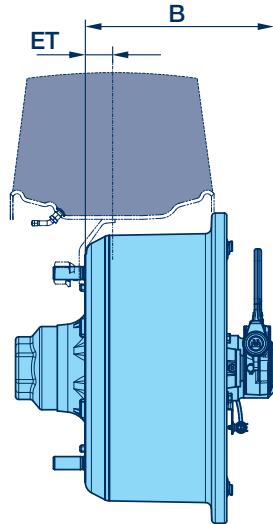

BPW Axle stub for low loader tyres 15" bis 19.5"

Axle type	Axle load	Wheel stud	Ø H / K (mm)	Brake	ET/M	Dimension B	Tyre
NRD ...	6 t	10 x M22 x 1.5	225 / 175.8	SN 3012	ET = 55	311	245/70 R17.5
NRD ...	12t	10 x M22 x 1.5	225 / 175.8	SN 3020	M = 290	382	235/75 R17.5

BPW Axle stub for tyres 20" bis 24"

Axle type	Axle load	Wheel stud	Ø H / K (mm)	Brake	ET/M	Dimension B	Tyre
RDV ...	7.1t	10 x M22 x 1.5	335 / 280.8	SN 4212	ET = 88	310	275/70 R22.5
RDS ...	10t	10 x M22 x 1.5	335 / 280.8	SN 4218	ET = 0	371	385/65 R22.5
RDZ ...	16t	10 x M22 x 1.5	335 / 280.8	SN 4220	M = 432	316	14.00 R20
MVB ...	10t	10 x M22 x 1.5	335 / 280.8	SN 4218	ET = 40/65		385/65 R22.5
RDZ ...	14 t	10 x M22 x 1.5	335 / 280.8	SN 4220	M = 344		12.00 R20
MZM ...	20t	10 x M24 x 1.5	335 / 280.8	SN 4220	M = 360		325/95 R24

BPW Heavy duty stub axles for industrial applications

Axle type	Axle load	Wheel stud	Ø H / K (mm)	Brake	Tyre
NMZ ...	28 t at 10 km/h	10 x M22 x 1.5	225 / 175.8	SN 3020	15" Pneumatic tyres
MZM ...	60 t at 5 km/h	24 x M22 x 1.5	425 / 370.8	SN 5020	from 24" pneumatic tyres

Other versions on request, as well as stub axles without brake.

The specified axle loads apply with pneumatic tyres up to 105 km/h. The following axle load increases are permissible for vehicles with a lower permissible maximum speed: Vmax. 40 km/h +10 %, Vmax. 25 km/h +25 %, Vmax. 10 km/h +40 %.

1.2.8 Swing axles | 6 - 60 t axle load

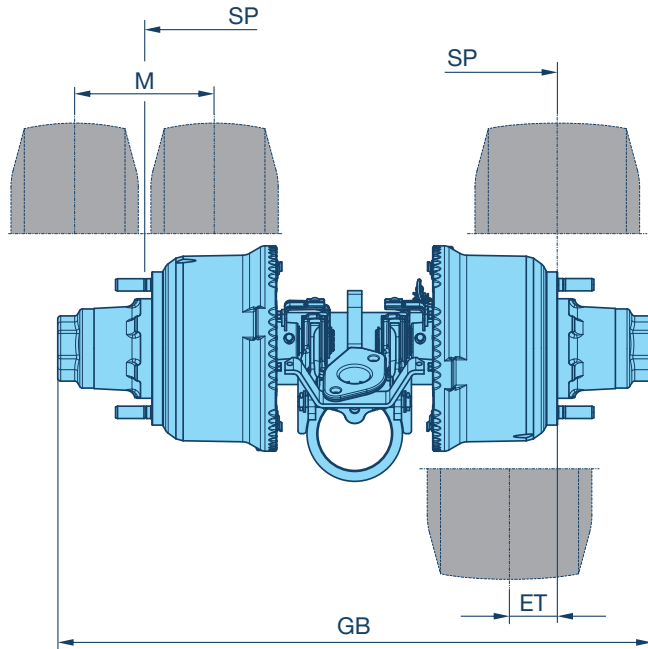

BPW swing axles for 15" to 24" tyres

Axle type	Axle load	Wheel stud	Ø H / K (mm)	Brake	SP	GB	ET/M	Tyre
NRD ...	6 t	10 x M22 x 1.5	225 / 175.8	SN 3012	454	690	ET = 55	245/70 R17.5
NRD ...	9 t	10 x M22 x 1.5	225 / 175.8	SN 3015	680	928	ET = 0	285/70 R19.5
NRD ...	12 t	10 x M22 x 1.5	225 / 175.8	SN 3020	910	1234	M = 290	235/75 R17.5
MSF ...	12 t	10 x M22 x 1.5	335 / 280.8	SN 4218	845	1189	ET = 0	385/65 R22.5
MZM ...	16 t	10 x M22 x 1.5	335 / 280.8	SN 4220	960	1382	M = 360	325/95 R24
NRD ...	7 t	10 x M22 x 1.5	225 / 175.8	SN 3012	518	794	ET = 66	285/70 R19.5
NRD ...	12 t*	10 x M22 x 1.5	225 / 175.8	SN 3015	735	1047	M = 248	215/70 R17.5
NMZ ...	13 t	10 x M22 x 1.5	225 / 175.8	SN 3020	800	1140	M = 280	235/75 R17.5
MZM ...	14 t	10 x M22 x 1.5	335 / 280.8	SN 4220	960	1306	M = 350	12.00 R20
MZM ...	20 t	10 x M22 x 1.5	335 / 280.8	SN 4220	1120	1622	M = 360	325/95 R24

* Technical axle load max. 9.7 t

BPW Heavy duty swing axles for industrial applications

Axle type	Axle load	Wheel stud	Ø H / K (mm)	Brake	SP	GB	ET/M	Tyre
NMZ ...	18 t at 25 km/h	10 x M22 x 1.5	225 / 175.8	SN 3020	800	1140		15" (pneumatic and CSE tyres *)
RDB ...	25 t at 5 km/h	10 x M22 x 1.5	335 / 280.8	SN 4218	600	974	ET=66	22.5" Pneumatic tyres
MZM ...	40 t at 15 km/h	10 x M24 x 1.5	335 / 280.8	SN 4220	1120	1581		20" (pneumatic and CSE tyres *)
MZM ...	60 t at 5 km/h	24 x M22 x 1.5	425 / 370.8	SN 5020	1320	1799		from 24" pneumatic tyres

* CSE = Solid rubber tyres

1.2.8 Swing axles | Tandem swing axles, 2 x 12 - 20 t axle load

For heavy low-loader special vehicles, BPW also offers tandem swing axles with load compensation but without suspension.

A pendulum beam mounted around the transverse axis connects two swing axles mounted to rotate around the longitudinal axis so that the wheels can follow any unevenness in the ground.

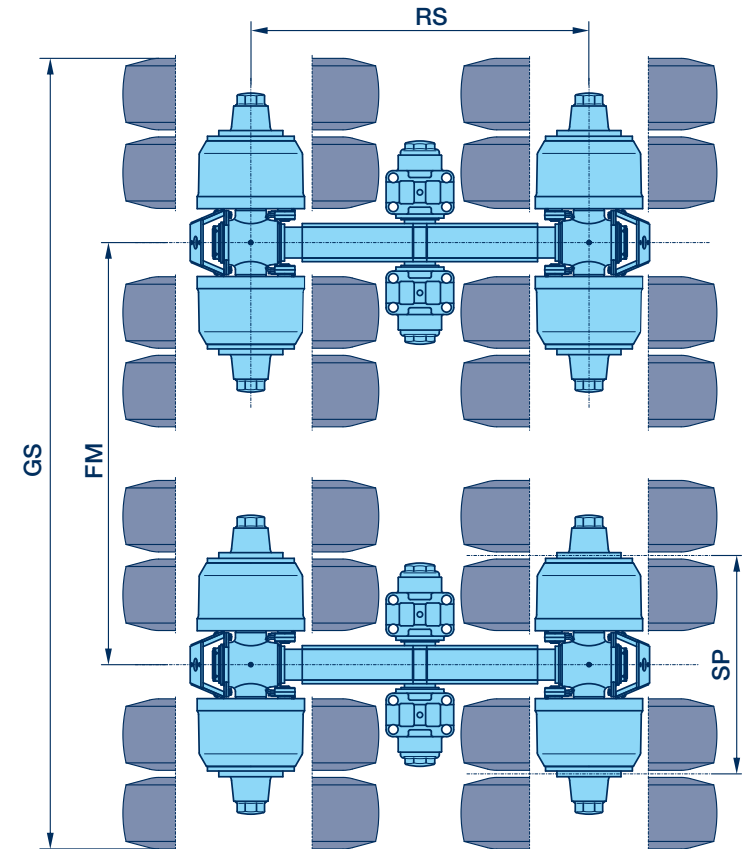

BPW tandem swing axles for 15" to 24" tyres

Axle type	Axle load	Wheel stud	Ø H / K (mm)	Brake	SP	RS	FM	GS	Tyre
NMZ ...	2 x 12 t	10 x M22 x 1.5	225 / 175.8	SN 3015	890	1350	1600	3025	235/75 R17.5
MZF ...	2 x 12 t	10 x M22 x 1.5	335 / 280.8	SN 4220	960	1480	1800	3420	12.00-20
MZM ...	2 x 16 t	10 x M22 x 1.5	335 / 280.8	SN 4220	960	1550	1840	3457	12.00-20
NMZ ...	2 x 13 t	10 x M22 x 1.5	225 / 175.8	SN 3020	950	1350	1800	3995	315/70 R15
MZF ...	2 x 14 t	10 x M22 x 1.5	335 / 280.8	SN 4220	955	1480	1800	3417	12.00-20
MZM ...	2 x 20 t	10 x M22 x 1.5	335 / 280.8	SN 4220	1125	1700	2170	4097	14.00 R20

1.2.9 Turntables

Turntables are used as 360° pivot bearings between the chassis and the bogie (turntable) on turntable trailers and on positively steered semi-trailers. BPW offers turntables with double row of balls for the highest requirements. The upper ring is connected to the lower ring by the supporting balls and the retaining balls. The supporting ball row primarily transmits the vertical weight force, while the retaining ball row supports the horizontal force transmission.

- Maximum safety and service life even in off-road applications thanks to double-row bearing arrangement
- Rings are made of high-strength steel (cold-formed, butt-welded and calibrated)
- Ball chambers are permanently protected against contamination by labyrinth seals
- Best surface protection due to impact, corrosion and weather resistant paint (deep black RAL 9005), which passes the salt spray test according to DIN EN ISO 9227

[Brochure BPW turntables](#)

[Installation and maintenance instruction BPW turntables](#)

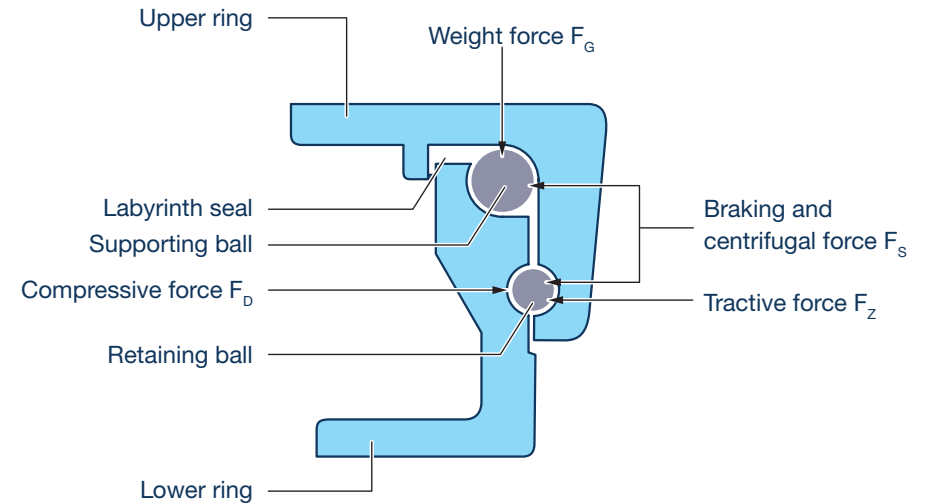

1.3 Recommendation for use

1.3.1 Axles and air suspensions (Europe)

S = Single wheels

Z = twin wheels

* LightTube available for ALO, ALM, ALU

¹⁾ ALO / ALM / ALMT

²⁾ ALU

Recommendation	Use	Axle load	Air suspension series	Tyres	Spring centre	Trailing arm 70 mm 100 mm	Axle beam	Clamping	Notes and options
1	On-road conditions	9t	ECO Air (EA)	S	≥ 1200	Trailing arm		Clamped	Lines 1 - 3 and 7 - 9 Vehicles with split air bag (combi-airbag) must not be moved in the unvented condition when manoeuvring in ferry traffic. Lines 1 - 11 The use of a stroke limitation is required for container and coil vehicles. The use of a lowering device or stroke limitation is required for tippers. Lines 7 - 11 Optional use of HD components for sophisticated applications - HD shock absorbers for rough road usage and for high off-road speeds - Ø 360 mm air bag (for fast height adjustment with sudden loading) with reinforced bag plate
2			AL II			1 x 56*	○ 146 x 10 ¹⁾ □ 120 x 10 ²⁾		
3						1 x 62			
4		S / Z		≥ 1100	□ 120 x 15				
5		Z	< 1100						
6		S / Z		1 x 65		Welded	□ 120 x 17		
		11.8 t for SN 4220 12 t for SN 3020 / SN 3620							
7	Off-road conditions	9t	ECO Air (EA)	S	≥ 1200	Trailing arm		Clamped	Lines 9 - 11 Toughest off-road use, e.g. mining operations or use on unconsolidated, heavy grounds, which are navigable only with all-wheel drive machines. Mandatory use of air bags with reinforced bag plate.
8			AL II			1 x 62	○ 146 x 10 ¹⁾ □ 120 x 15 ²⁾		
9						1 x 65			
10		S / Z			□ 120 x 17				
11		10 t - 12 t	SL			1 x 57 / 2 x 43	□ 150 x 16	Welded	

- Deviations from the required equipment features may impact the extent and validity of the ECO Plus warranty. Your BPW contact person is at your disposal for further information and a personal consultation.
- The data sheets of the BPW air suspension must be observed for the exact specification of the air suspension modules according to the application areas and the possible combinatorial function of the components mentioned incl. TE-3075.0).

- Disc brake cover plate
On-Road: In on-road use, a cover plate is generally not required. Rough use: In rough use cover plates are recommended. In addition to off-road use, rough use also includes more difficult on-road use (e.g. high levels of dirt, lots of ice and snow).
- Beyond an axle load of 10 t, the use of Ø 360 mm air bags is mandatory.

1.3.1 Axles and air suspensions | ECO Plus warranty

For air-suspended running gears, without mileage limit

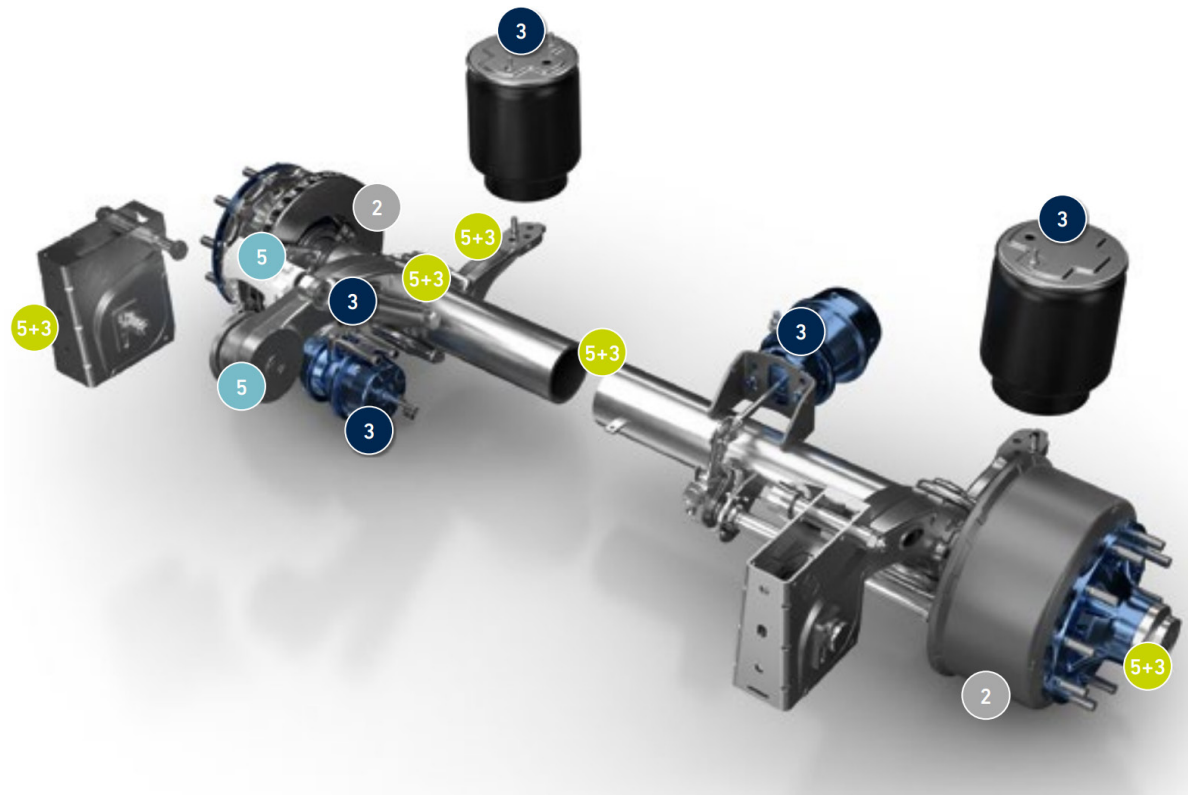

Example table: for 9 t BPW air suspension systems in on-road and standard off-road use in Europe

- Full service check at a BPW service workshop for 5+3 year warranty
- also for trailers from 2. hand

● 2 years	● 3 years	● 5 years	● 5+3 years
Brake disc	Brake cylinder	Brake caliper	Axle beam
Brake drum	Air bag	Air suspension rubber bushing	Hanger brackets
	Shock absorber	Trailing arm	Hub and wheel bearing
		Air bag carrier	Clamping

More information about the ECO Plus Warranty: [ECO Plus Warranty documents](#)

1.3.2 Axle loads and speed

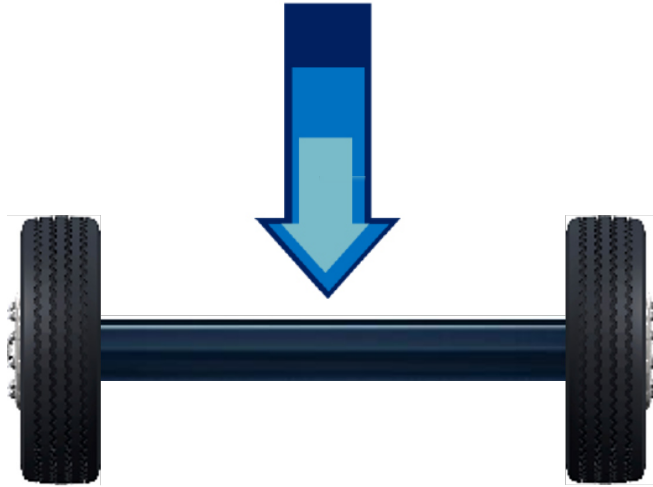

Vmax 40 km/h => +10 % Axle load

Vmax 25 km/h => +25 % Axle load

Vmax 10 km/h => +40 % Axle load

- The axle loads indicated on the nameplate are maximum values on the ground up to 105 km/h.
- For higher loads at lower speeds, confirmation from BPW is required.
- For vehicles with a maximum permissible speed of less than 80 km/h, the above axle load increases are generally possible (exceptions for steering and special axles).
- The suspension must always be considered separately.

1.3.3 Wheel brakes

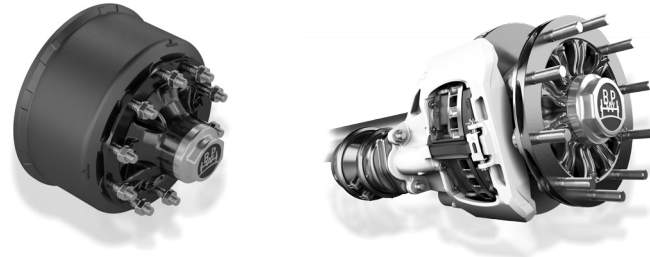

- + advantageous
- 0 neutral
- disadvantageous

	Drum brake	Disc brake	Comment
Robustness in general	++	+	Drum brake more capable of overload as well as better when the vehicle is stationary for a long time
Braking distance	+	+	Depending on braking system (EBS is better)
Fading	-	+	Fading of the drum brake presents itself predictably
Insensitivity to poor compatibility	++	0	Drum brake can also be combined well with older motor vehicles (ABS instead of EBS)
Insensitivity to coarse dirt	++	0	Closed drum brake design; covers available for disc brake
Brake force dosing	0	+	More uniform braking forces left / right with disc brake
Weight	+	++	Particularly low with ET0 disc brakes

1.3.3 Wheel brakes | Disc brake versions



- + advantageous
- 0 neutral
- disadvantageous

	TS2 3709	TS2 4309	TSB 4312	Comment
Ordinary forwarding company	+	+	+	
High percentage of mountainous routes	-	+	+	
Regional distribution traffic	-	+	+	
Frequently changing combinations	-	+	+	
Off-road conditions	-	0	0	Only with cover plates
Construction site vehicles	--	-	-	
Lightweight construction	+	0	0	

1.3.4 Brake system

- + advantageous
- 0 neutral
- disadvantageous

Motor vehicle	Trailer			
	EBS + Disc brake:	ABS + Disc brake:	EBS + Drum brake:	ABS + Drum brake:
EBS + Disc brake:	+	0	+	0
ABS + Disc brake:	+	0	+	0
EBS + Drum brake:	0	--	+	+
ABS + Drum brake:	-- ¹⁾	- ²⁾	-	+

¹⁾ Unacceptable response and fading of the towing vehicle.

²⁾ Equip trailer with an adjustment valve (only in this case!).

EBS stands for „Electronically Controlled Braking System“. The signal from the brake pedal is sent electronically to the control unit, from where the brakes on the wheels are activated pneumatically. EBS systems have, among other things, an integrated ABV function (automatic anti-lock braking system: short braking distance, optimum driving stability and steerability; also called ABS for anti-lock braking system) and react faster than conventional braking systems.

1.3.5 Offset for single wheels (disc brake)

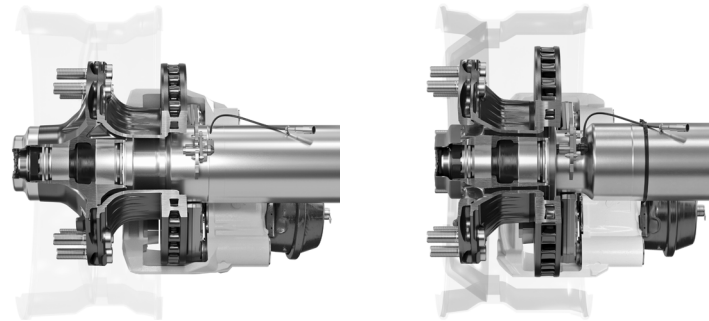

- + advantageous
- 0 neutral
- disadvantageous

	Offset 0	Offset 120	Comment
Weight	+	0	ET 120 is the market standard for TS2 4309; ET 0 is weight benchmark, esp. with TS2 3709 (difference ET 0 / ET 120 up to 10 kg / axle incl. wheels)
Free space in the center of the axle; compactness	0	+	Important for large spring centers with underslung trailing arms
Protected position of the brake	Airstream cools the brake disc	Protection from moisture and dirt	Brake disc cover plates available for ET 120, and shaft cover for ET 0
Multiple usability of the wheels	Same wheels for drum braked axles as for disc braked axles	Often same wheels as for truck front axle	Argument in the mixed fleet, or in the event of a breakdown

1.3.6 Benefits of Air suspension compared to Mechanical suspension

- Maximum ride comfort and safety for load, vehicle, driver in all load conditions (load-dependent spring characteristics)
- Low dynamic wheel loads and large axle load compensation travel (high driving safety, significantly less road damage)
- Braking force compensation of the axles and simple realization of the load-dependent braking force, thus also tyre protection
- Maintenance-free and low-noise
- Height adjustability for easy loading and unloading
- Combination with axle lifts, drive height control or load measurement
- BPW air suspension systems have been used successfully for decades, even under off-road conditions

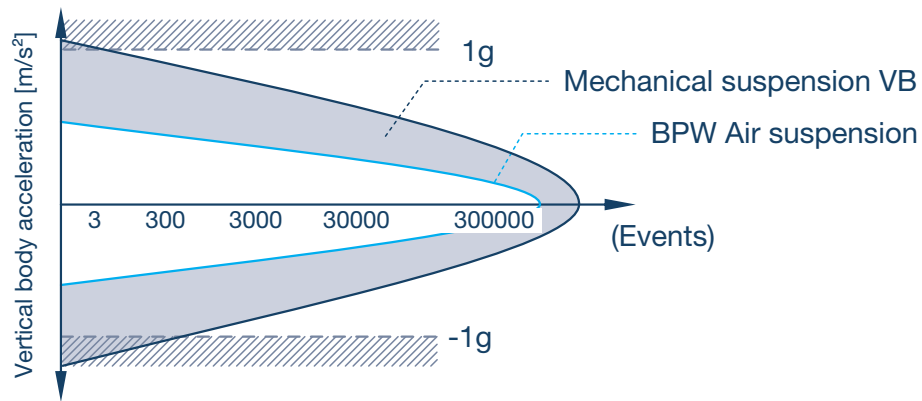

Spring characteristics

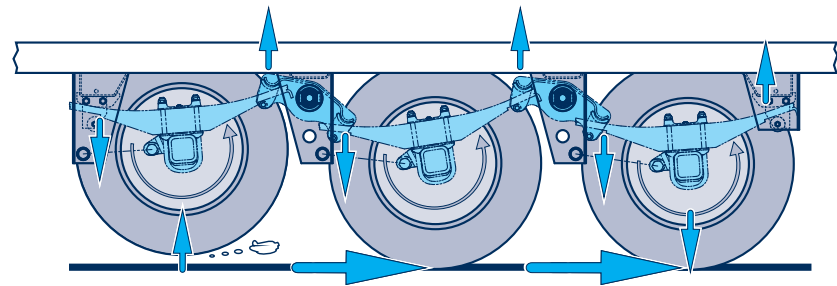
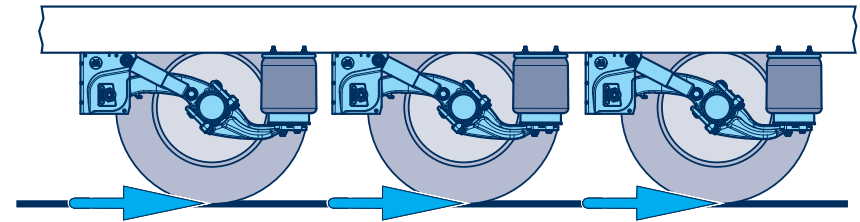

Brake force compensation

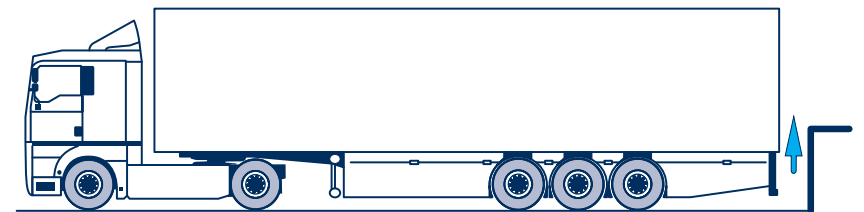

Height adjustment

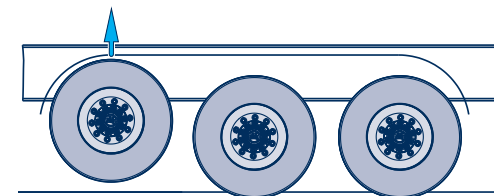

Axle lift

1.4 Website / Configurator / Further products

1.4.1 bpw.de

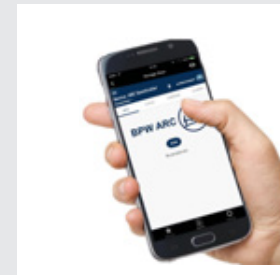
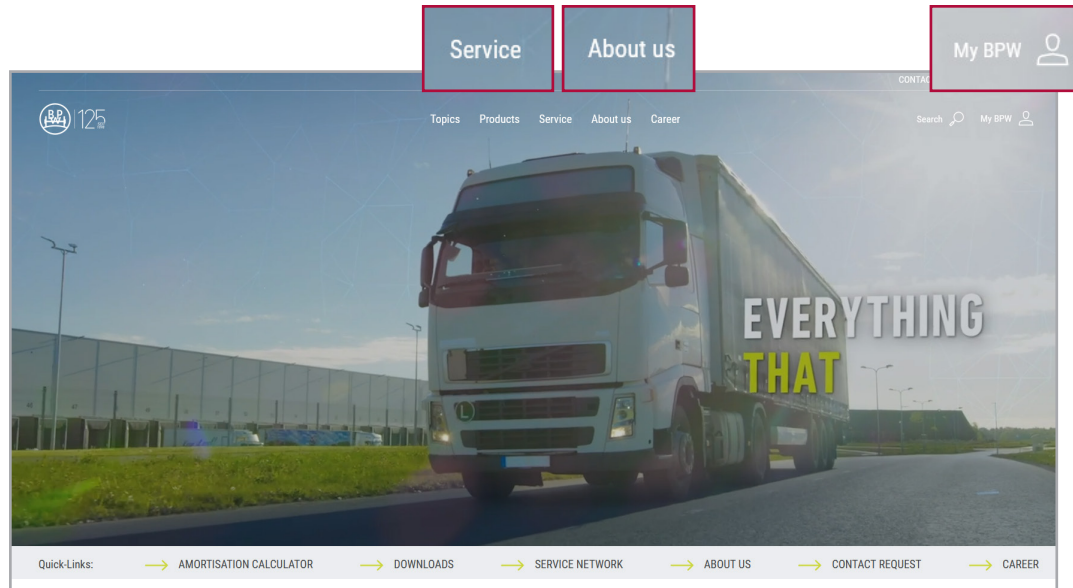

My BPW

Easy access for customers: to drawings, spare parts lists, data sheets, technical information, test reports / approvals, ...

[My BPW](#)

About us / BPW Fanshop

Here you will find reference books and other articles related to BPW.



Our books in the publishing house Moderne Industrie:

[Running gear systems for towed vehicles](#)

[Electric drives for light commercial vehicles](#)

Service / Downloads

Here you can find information about all products. Also search/filter function for workshop manuals, spare parts information, installation instructions etc..

[Service / Downloads](#)

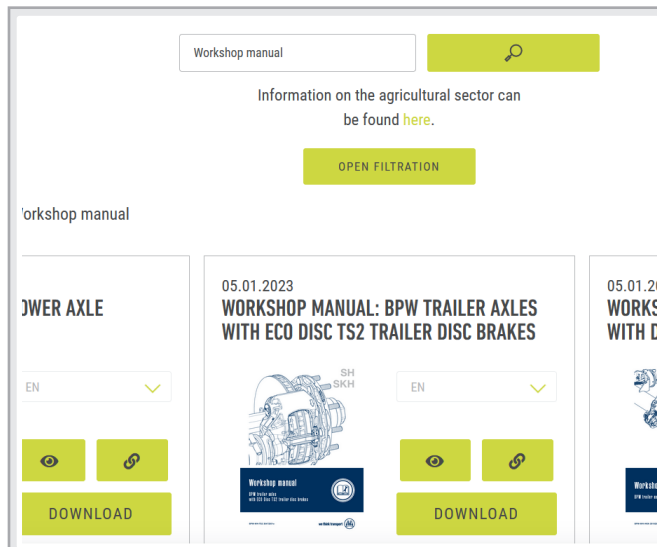

1.4.2 Configurator

[Configurator](#)

Make things simple!

+ BRAKE
TS2 3709
TS2 4309

Configure and order online

we think transport 

The advertisement features a 3D exploded view of a commercial vehicle brake assembly. The components, including a brake caliper, disc, and various mounting parts, are shown in a semi-transparent, exploded state against a dark, textured concrete wall background. A prominent white text overlay reads "Make things simple!". A yellow circular icon with a shopping cart symbol and the text "Configure and order online" is positioned in the upper right. A semi-transparent information box in the lower center, containing a plus sign, the word "BRAKE", and the part numbers "TS2 3709" and "TS2 4309", is highlighted with a mouse cursor. The BPW logo and the slogan "we think transport" are located in the bottom right corner.

1.4.3 Landing gear

BPW landing gears ensure safe and efficient parking and coupling of the trailer. Features of the current generation are:

- Lifting load per set 24 tonnes; test load per set 50 tonnes
- Weight-reduced construction with continuous screw-on plate for flexible mounting
- Reinforced leg ends for maximum strength
- Optimised gearbox for low crank forces and simplified shifting between high and low gears
- Long-term lubrication with 3 years maintenance-free operation
- Other versions available as drawbar supports
- Extended warranty period of 36 months

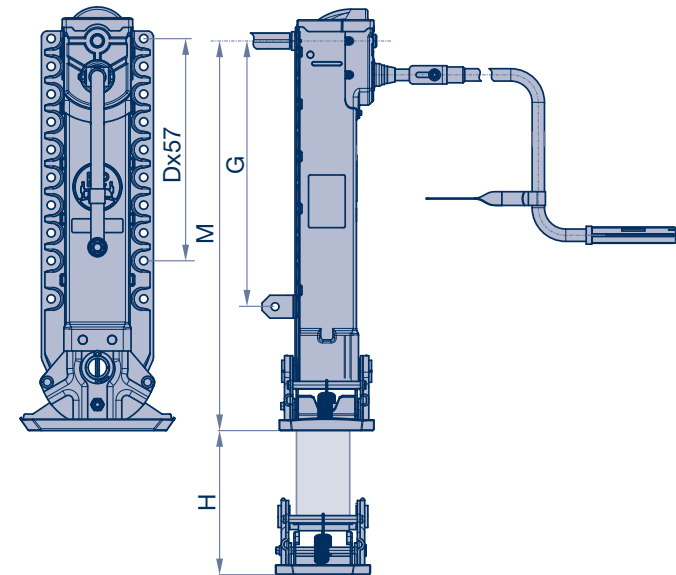

Standard versions

Length M	Hub H	G	D
650	305	380	6
700	355	430	7
750	405	480	8
800	455	530	8
850	505	580	9
900	540	630	9

Support feet

Version S	Version T	Version R	Version A



[Product information drawbar supports](#)

[Product information landing gear](#)

[Installation and operating instructions](#)

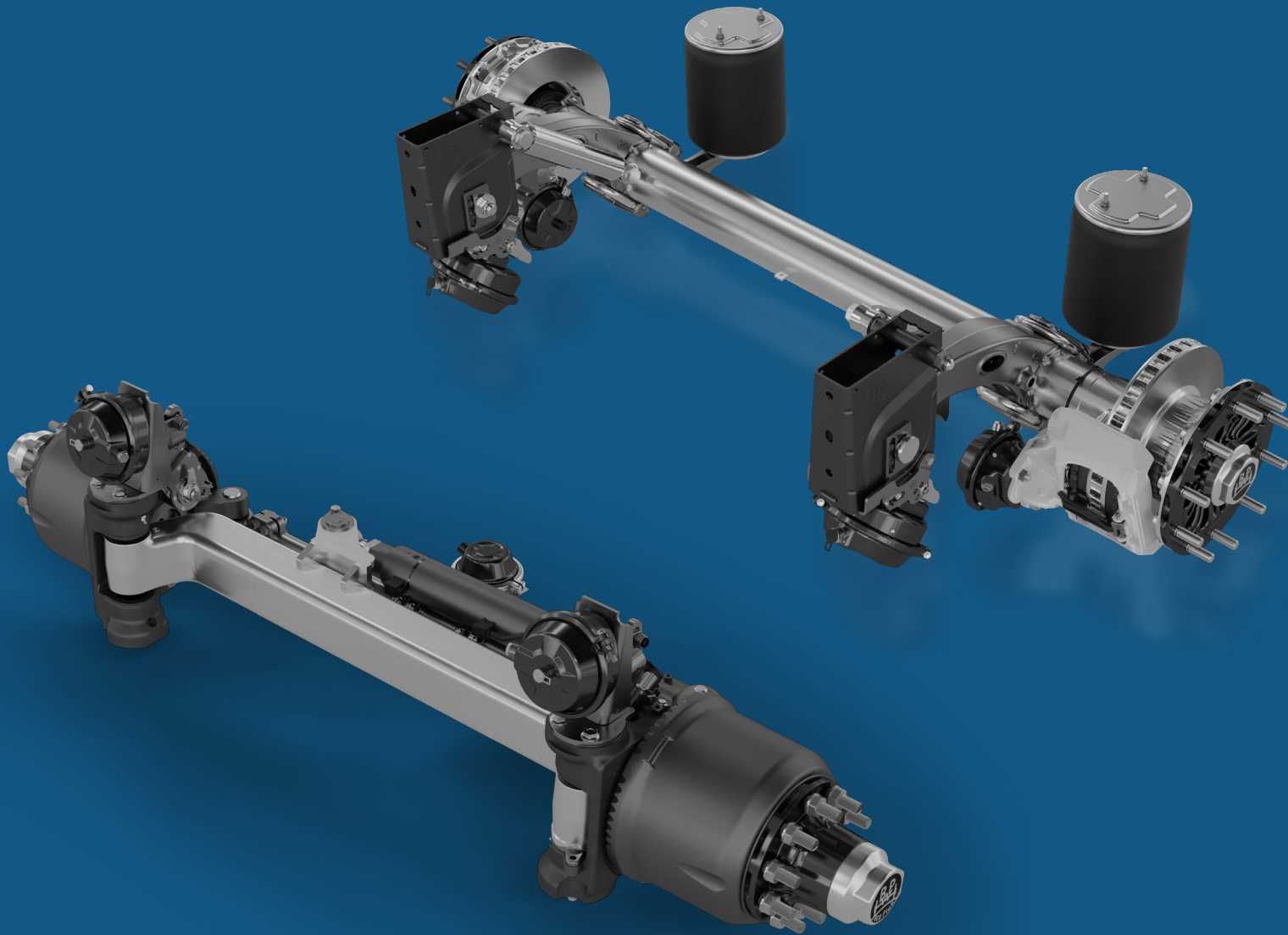

2

AXLES

- 2.1 Identification
- 2.2 Track width
- 2.3 Wheel connections
- 2.4 Self-steering axles
- 2.5 Forced steering axles
- 2.6 Stub axles
- 2.7 Swing axles
- 2.8 Additional equipment

2.1 Identification

2.1.1 Type plate of the axles

The type plate of the axle contains the most important information on the specification and date of manufacture of the axle with brake. Bar and QR codes make reading easier.

19	05	5	0	771	
19					Year
	05				Calendar week
		5			Day of this calendar week
			0		Production facility
				771	Sequential production number

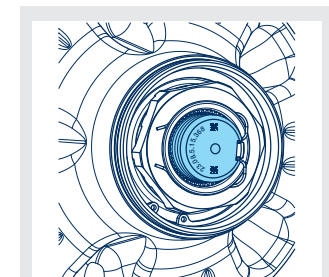
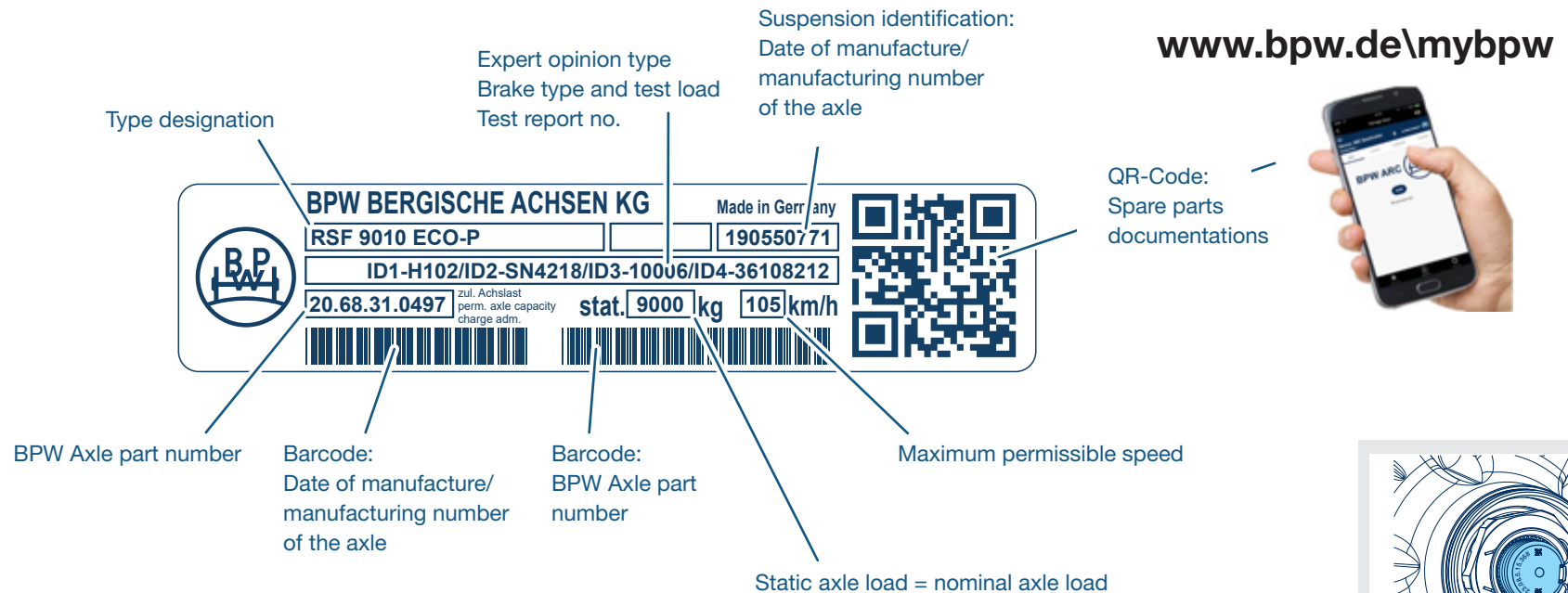

If the type plate is lost: Use the axle beam welding number on the spindle (right side).

2.1.2 Important type designations for axles

Example:

H	S	F	A	H	LL	9010	12"	ECO Plus 3
---	---	---	---	---	----	------	-----	------------

		Axle beam	Brake	Tyre	Year of manufacture
H		□			1982-
R		○	SN 420	20 - 24"	1982-
M		●			1982-
KH		□	SN 360	19.5"	as of 1988
KM		■			1985-
KR		○			1985-
KRD		●			1985-
NH		□	SN 300	15/17.5" (12")	as of 1993
NR		○			1982-
NRD		●			1982-
NM		■			1982-
SH		□	SB 4345	20 - 24"	1996 - 2010
		□	SB 4309	22.5"	2003 - 2010
		□	TSB 4312	20 - 24"	2010-
		□	TSB 4309	22.5"	2010-
		□	TS2 4309	22.5"	2019-
SR		○	TS2 4309	22.5"	2019-
SKH		□	SB 3745	19.5"	1998 - 2010
		□	TSB 3709	19.5"	2010-
		□	TS2 3709	19.5" (22.5")	2019-
SKR		○	TS2 3709	19.5" (22.5")	2019-
SNR		○	SB 3307	17.5"	2005-
SM		■	SB 4345	20 - 24"	1996 - 2010
		■	TSB 4309	22.5"	2010-
		■	TS2 4309	22.5"	2019
SKM		■	SB 3745	19.5"	1998 - 2010
		■	TSB 3709	19.5"	2010-

2.1.2 Important type designations for axles

Example:

H	S	F	A	H	LL	9010	12"	ECO Plus 3
---	---	---	---	---	----	------	-----	------------

				Wheel version	
B				For single wheels, wheels with offset	
S				For single wheels, wheels without offset	
Z				For twin wheels	
I				Wheel spiders for TRILEX wheel rims, single wheels	
IZ				Wheel spiders for TRILEX wheel rims, twin wheels	
	F			Wheel studs M 22 x 1.5, without wheel nuts	
	M			Wheel nuts for stud or hub centering separate	
		A		For hub centering / for aluminium wheels	
			A	With aluminium hub	
			H	For hanging brake cylinders	
				L	Steering axle for positive steering series L
				LL	Self-steering axle series LL
				P	Swing axle
				ST	Stub axle
				6006 to 20010	Axle load (kg) + quantity of wheel studs per hub
				-15	Axle beam - wall thickness, e.g. 15 mm
				-1	Hub bearing version (e.g. 14 t)
				/3	Wheel connection - 10 wheel studs, pitch circle 335 mm (only K.)
				/12° to /45°	Steering angle of steering axle
				Hub bearing versions	
				ECO	Trailer axle with ECO Unit
				ECO MAXX	Weight optimised trailer axle with ECO Unit
				ECO ^{Plus}	Weight-optimised trailer axle with ECOPlus Unit
				ECO PLUS 2	Weight-optimised trailer axle with ECO Plus 2 Unit 2007 -
				ECO PLUS 3	Weight-optimised trailer axle with ECO Plus 3 Unit 2015 -
				MAXX	Weight-optimized trailer axle with conventional hub system

2.1.3 Important type designations for air suspension units

Example:

HSF	ALO	A	LL	3/	9010	/12°	V	30 K	ECO Plus 3
-----	-----	---	----	----	------	------	---	------	------------

		Axle type	
H...		See explanation of axle types siehe Kapitel 1.2.1	
K...			
N...			
R...			
u. a.			
		Air suspension series	Nominal ride height
SLO		Straight overslung trailing arms	420 - 490
SLM		Cranked overslung trailing arms	360 - 440
SLU		Underslung trailing arms	220 - 330
ALO		Straight overslung trailing arms	380 - 490
ALM		Cranked overslung trailing arms	305 - 420
ALMT		Cranked overslung trailing arms	245 - 290
AL		Underslung trailing arms	175 - 300
EAAU		ECO Air	205 - 350
EAAM			245 - 370
EAAO			335 - 385
EABU			260 - 330
EABM			300 - 425
EABO			330 - 510

2.1.3 Important type designations for air suspension units

Example:

HSF	ALO	A	LL	3/	9010	/12°	V	30 K	ECO Plus 3
-----	-----	---	----	----	------	------	---	------	------------

								Air suspension series	
A								With axle lift device	
R								With auxiliary frame (= FH + 100 mm)	
U								With U-stabiliser	
	L							With steering axle, series L steering angle max. 45°	
	LL							With self-steering axle, series LL steering angle max. 27°	
		-						Single axle	
		2/						Tandem axle suspension	
		3/						Tri-axle suspension	
			6006 to 13010					Axle load (kg) + quantity of wheel studs per hub	
				/12° to /45°					Steering angle of steering axle
								Hanger bracket version	
		A						Aluminium hanger brackets	
		C						Channel crossmember	
		D						Hanger brackets with top plate	
		E						Hanger brackets without top plate	
		K						Bolted on hanger brackets	
		S						Taper mounted hanger brackets (70 mm wide)	
		T						with member (trailing axle)	
		V						Adjustable hanger brackets	
		X						With stainless steel hanger brackets	
		Y						Without mounted hanger brackets, hanger brackets separate	

2.1.3 Important type designations for air suspension units

Example:

HSF	ALO	A	LL	3/	9010	/12°	V	30 K	ECO Plus 3
-----	-----	---	----	----	------	------	---	------	------------

Air bag versions	
30	Air bag Ø 300 mm, for stroke 220 mm (standard)
30 K	Ø 300 mm, for stroke 190 mm
36	Ø 360 mm, for stroke 220 mm (standard)
36-1	Ø 360 mm, for stroke 260 mm
36-2	Ø 360 mm, for stroke up to 450 mm
36 K	Ø 360 mm, for stroke 190 mm
G	Air bags with split piston
Z	Air bags loose, separate
Hub bearing version	
ECO	Trailer axle with ECO Unit, 1996 (1998) -
ECO MAXX	Weight optimised trailer axle with ECO Unit, - 2003
ECO Plus	Weight-optimised trailer axle with ECO ^{Plus} Unit, 2003 - 2023
ECO Plus 2	Trailer axle with ECO Plus 2 Unit, 2007 - 2015
ECO Plus 3	Trailer axle with ECO Plus 3 Unit, 2015 -
MAXX	Weight-optimized trailer axle with conventional hub bearing

2.1.4 Important type designations for mechanical suspension units

Example:

HSF	VB	U	LL	3/	9010	/12°	M	ECO Plus 3	ECO Cargo
-----	----	---	----	----	------	------	---	------------	-----------

		Axle type	
H...		See explanation of axle types siehe Kapitel 2.1.2	
K...			
N...			
u. a.			
		Suspension series	
VB		Mechanical suspension without braking load compensation, leaf springs overslung	
VBT		as before, but leaf springs underslung	
W		Double-axle unit, rigid, with two leaf springs and support axle, bearing blocks between the springs	
BW		Double axle unit, rigid, with two leaf springs and support axle, bearing blocks above the springs, with bronze bushes	
GW		Double axle unit, rigid, with two leaf springs and support axle, bearing blocks above the springs, with rubber bushes	
	U	With U-stabiliser	
	LL	With self-steering axle, series LL steering angle max. 27°	
		-	Single axle
		2/	Tandem axle suspension
		3/	Tri-axle suspension
		6006 to 13010	Axle load (kg) + quantity of wheel studs per hub
		/12° to /45°	Steering angle of steering axle

2.1.4 Important type designations for mechanical suspension units

Example:

HSF	VB	U	LL	3/	9010	/12°	M	ECO Plus 3	ECO Cargo
-----	----	---	----	----	------	------	---	------------	-----------

Version index	
B	Reinforced
BE	Reinforced, equaliser bearing with bronze bushes
C	
HD	Heavy duty version
HDE	Heavy duty version, equaliser bearing with bronze bushes
E	Equaliser bearing with bronze bushes
K	
KE	Equaliser bearing with bronze bushes
KN	Low construction height
L	Reinforced
LE	Reinforced, equaliser bearing with bronze bushes
M	Reinforced
ME	Reinforced, equaliser bearing with bronze bushes
MN	Reinforced, low construction height
MNE	Reinforced, low construction height, equaliser bearing with bronze bushes
Hub bearing versions	
ECO	Trailer axle with ECO Unit, 1996 (1998) -
ECO MAXX	Weight optimised trailer axle with ECO Unit, - 2003
ECO Plus	Weight-optimised trailer axle with ECO ^{Plus} Unit, 2003 - 2023
ECO Plus 2	Trailer axle with ECO Plus 2 Unit, 2007 - 2015
ECO Plus 3	Trailer axle with ECO Plus 3 Unit, 2015 -
MAXX	Weight-optimized trailer axle with conventional hub bearing
ECO Cargo	New running gear system as from 2013

2.1.5 Explanation of item numbers

In the BPW part number key you will find all the information on the type designations and part numbers clearly explained.

[Part number code](#)

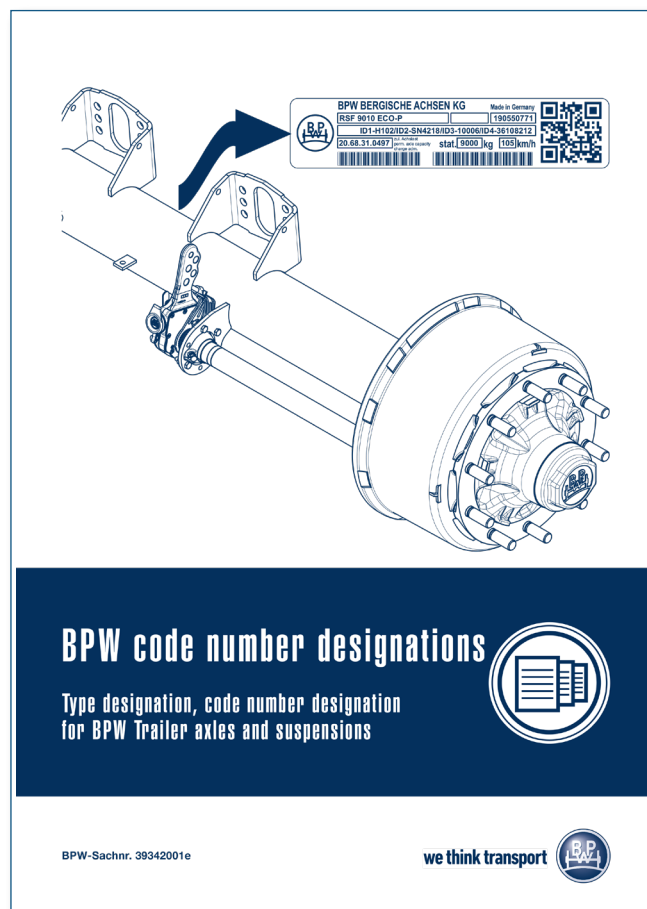

2.2 Track width

2.2.1 BPW declaration

- The track width is defined in DIN 70020-1 as the transverse distance between the tyre centers. For BPW axles without camber, this also corresponds to the track width at the hub flange in the case of offset = 0 mm and single tyres.
- For BPW axles with camber (only for square axles), the track width on the ground is specified for the unloaded axle. The tyre diameter has an influence on this nominal track width dimension on the ground. At BPW, it is usually not known which tyre size is mounted. Therefore, the following typical tyre radius is assumed to match the axle:

NH (17.5"-Wheels)	KH / SKH (19.5"-Wheels)	H / SH (22.5"-Wheels)
350 mm	350 mm	500 mm

The difference between the track width on the ground (unloaded) and the track width on the hub flange is therefore 4...5 mm

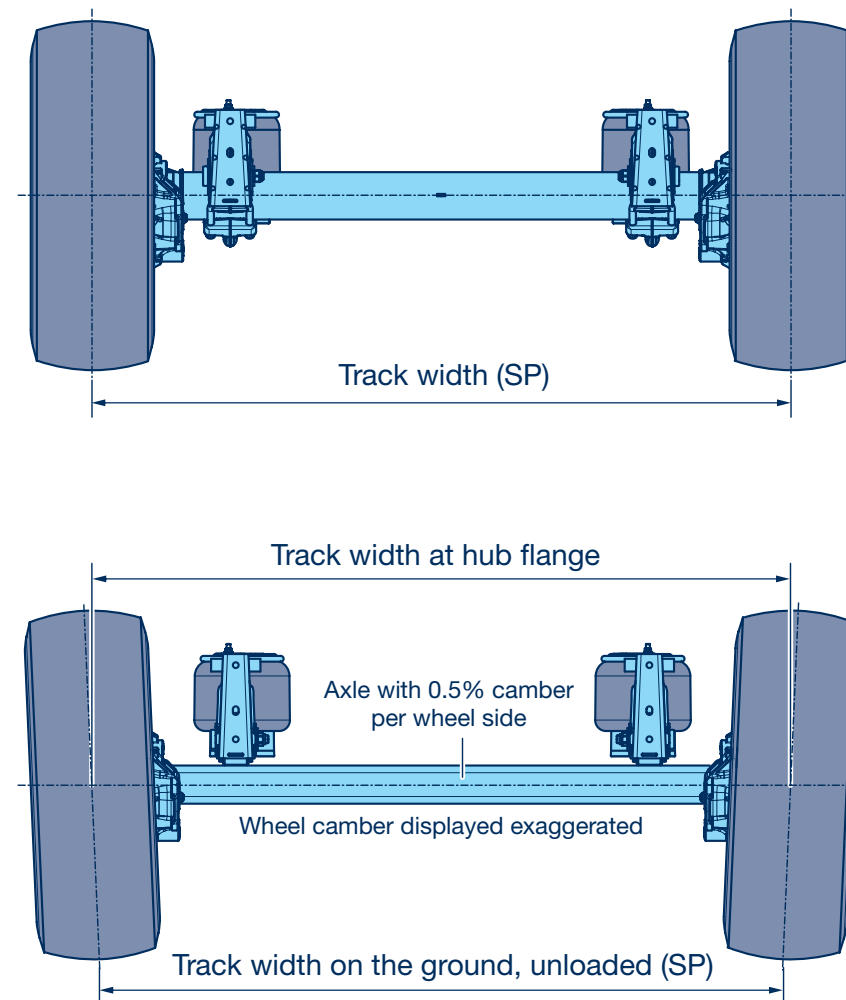

2.2.2 Twin wheels

- For twin wheels, the track width specification according to DIN 70020-1 refers to the contact area between the wheel discs. Therefore, in order to specify a track width, an assumption for the wheel disc strength t is necessary. This is additionally dependent on the wheel material, as aluminum wheels have thicker wheel discs than steel wheels.
- BPW works with the following assumptions:

Axle series	NH (17.5"-Wheels)	KH / SKH (19.5"-Wheels)	H / SH (22.5"-Wheels)
Steel wheels	$t = 10$	$t = 15$	$t = 10$
Aluminium wheels	$t = 20$	$t = 25$	$t = 20$

- Example: The nominal track width of an axle for 22.5" aluminum wheels (twin) is $2 \times 20 \text{ mm} = 40 \text{ mm}$ larger than the nominal track width of an axle for single wheels (made of aluminum or steel, because for single wheels the wheel disc thickness is not relevant for the track width).

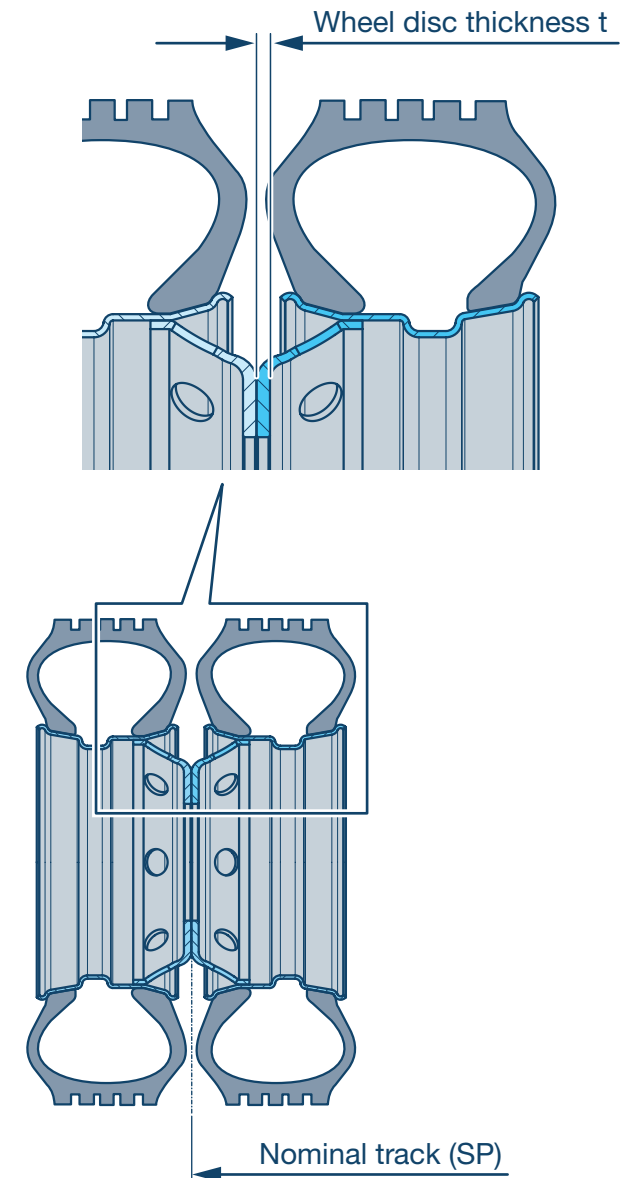

2.3 Wheel connections

2.3.1 General

For the safe attachment of wheels to BPW axles and their safe operation, it is essential to observe the following:

- Axle, wheels and tyres must be approved for the intended load. The components used must be matched to each other (e.g. centering, bolt hole and nut design, offset).
 - The contact surface between the wheel and hub must be clean, flat and free of top coat paint layers (*see chapter 3.7.2*).
 - The prescribed tightening torques must be observed in order to ensure that the wheels are securely fastened! The wheel studs must be clean and free of damage, and the nuts must be smooth-running. If necessary, lightly oil the contact surface between the wheel nut and the pressure plate. Do not oil or grease the thread of the wheel studs and wheel nuts. Retighten wheel nuts after the first load run.
 - If BPW axles **are supplied with wheel nuts** for centering already fitted, the type designation of the axles contains an M, e.g. HZM ...
 - BPW axles **without mounted wheel nuts** have a type designation with the identifier F, e.g. HSF....
- In the case of twin tyres, the centering seat of the hub must be at least 5 mm longer than the disc thickness of one wheel so that the outer wheel is centered on the hub.
 - when the wheel nuts are tightened, the wheel bolts must protrude at least 3 mm beyond the wheel nut. If this cannot be ensured for aluminum wheels, for example, longer wheel studs or shaft nuts and the corresponding wheels with a $\varnothing 32$ bore must be used.

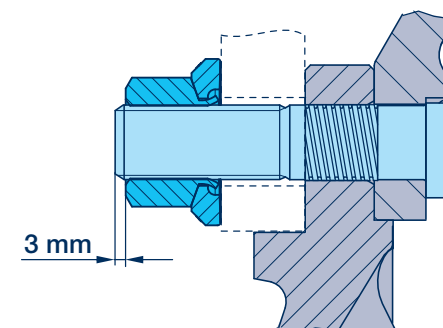
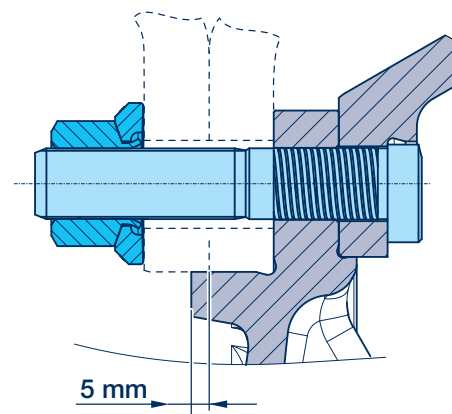

2.3.1 General

After pre-tightening, the wheel nuts must be tightened in the sequence shown (crosswise) to the specified tightening torque:

Stud alignment	Tightening torque
M14 x 1.5	125 Nm (120 - 130 Nm)
M18 x 1.5	290 Nm (275 - 305 Nm)
M20 x 1.5	380 Nm (360 - 400 Nm)
M22 x 1.5	510 Nm (485 - 535 Nm)
M22 x 2	460 Nm (435 - 485 Nm)



Spigot alignment	Tightening torque
M18 x 1.5	350 Nm (330 - 370 Nm)
M20 x 1.5	480 Nm (455 - 505 Nm)
M22 x 1.5	630 Nm (600 - 660 Nm)
M 22 x 1.5 aluminium wheels	630 Nm (600 - 660 Nm)
M24 x 1.5	860 Nm (820 - 900 Nm)

Wheel nut with pressure plate

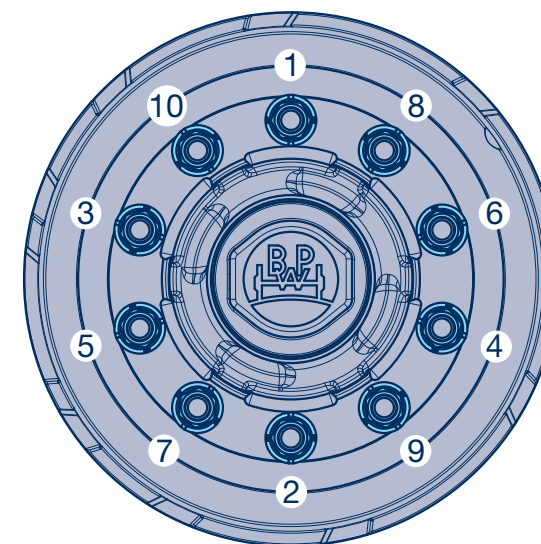
2.3.2 Centering

Wheel connections for commercial vehicle trailers are described in DIN 74361. A distinction is made according to the pitch circle diameter, the number and thread of the wheel studs and the diameter of the center hole. The wheels are centered differently on the hub.

- **Stud centering:** The wheel is centered by the special shape of the wheel stud holes in the wheel disc and by conical elements on the wheel nut and hub
- **Hub centering:** The wheel is centered on the hub seat of the axle via the center hole (both with close tolerances)

Depending on the system used, the wheels and axles must therefore be suitable. Wheel nuts and accessories must be selected appropriately.

Example	Pitch circle diameter	Quantity	Thread	Center hole Ø
Ø 205 / 6	205 mm	6	M18 x 1.5	160.8 mm
Ø 225 / 10	225 mm	10	M22 x 1.5	175.8 mm
Ø 275 / 8	275 mm	8	M22 x 1.5	220.8 mm
Ø 335 / 10	335 mm	10	M22 x 1.5	280.8 mm

Stud centering

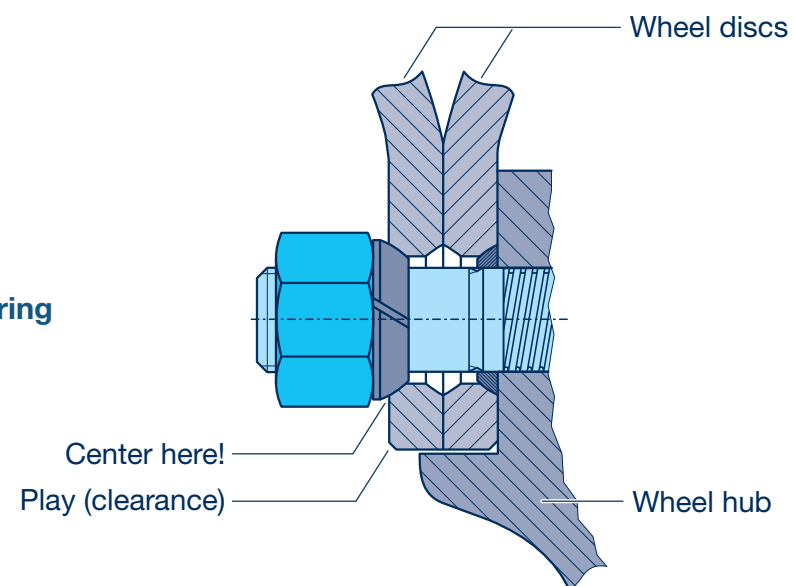

Hub centering

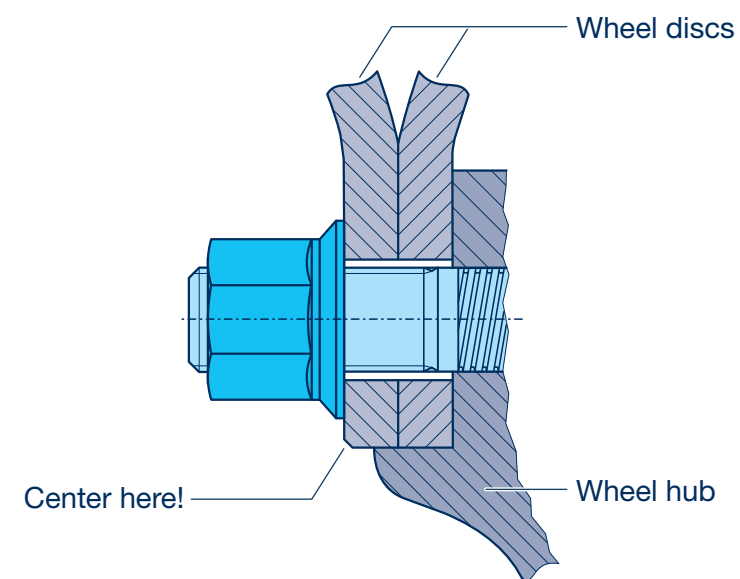

2.3.2 Centering

- **Double centering:** So-called double-centered wheels are used for the widespread double centering. These are steel wheels that are suitable for both hub and stud centering due to the design of the bolthole geometry and the close tolerance center hole design.

When mounting double-centered wheels on axles with wheel nuts for centering (pressure plate N, see DIN 74361-3), shaft inserts (1) must be used at 2 opposite positions. These are of different lengths for single or twin tyres:

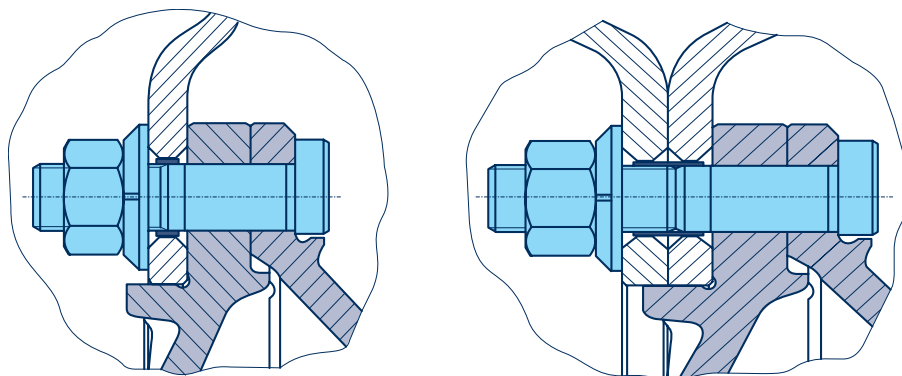

Double centering

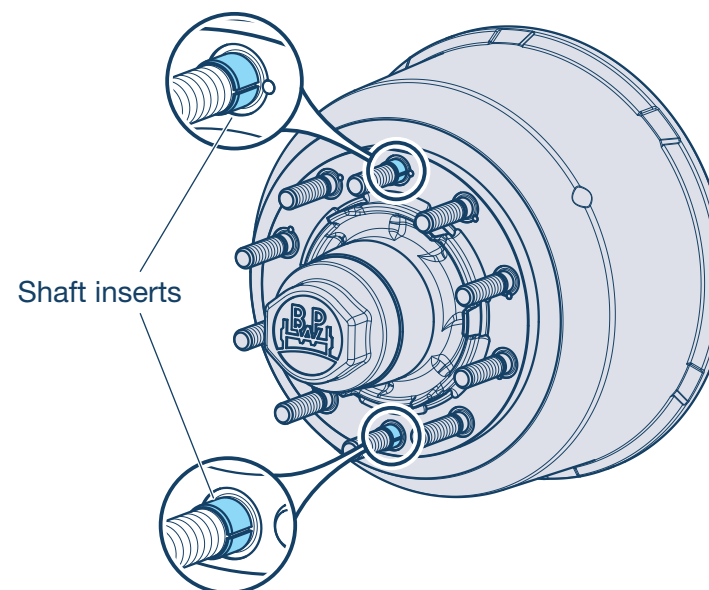
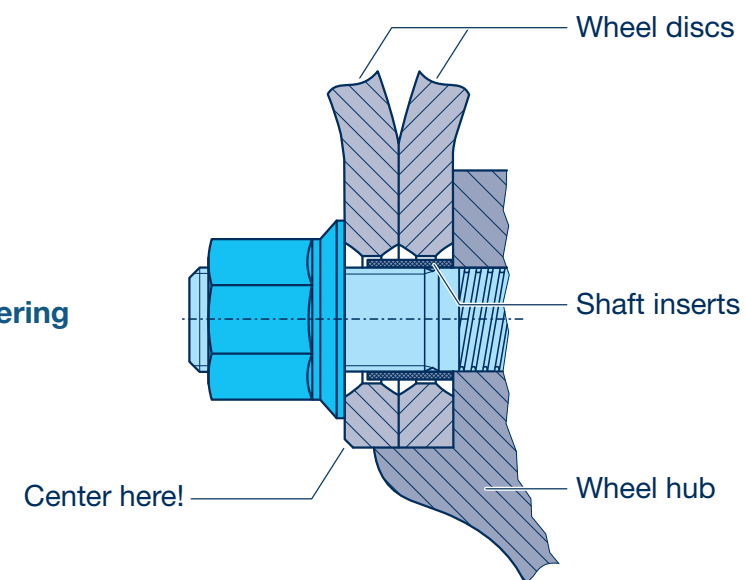

2.3.3 Aluminium wheels

- Commercial vehicle aluminum wheels are usually designed for hub centering. Wheel nuts with pressure plates must be used for mounting.
- Since the flange thickness of aluminium wheels is greater than that of steel wheels, it must be checked whether the wheel studs of the axles are long enough for mounting aluminium wheels with stud hole $\text{Ø } 26$.
- If the wheel bolt length is not sufficient (e.g. for axles with disc brakes), aluminum wheels with bolt hole $\text{Ø } 32$ can be used in conjunction with shaft nuts. However, the outer twin wheel must still be guided on the hub seat by at least 5 mm; this must be checked carefully. The shaft nuts alone would not provide secure wheel centering, and wheel mounting, for example after a flat tyre, would then hardly be possible.

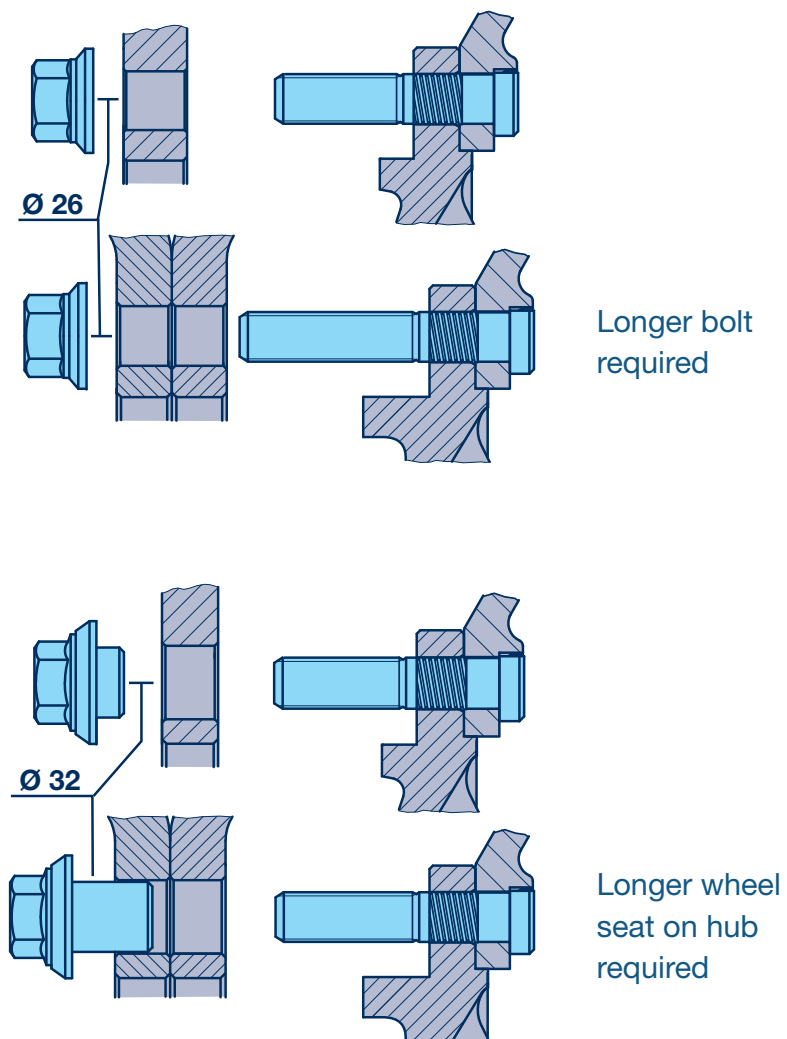

2.3.4 Standard axles ECO Plus 3 | 9 t

	TS 2 ET=0			TS 2 ET=120	SN 4218			SN 3620
	S	Z		B	S		Z	S
Wheel connection	335 / 10	335 / 10	335 / 10	335 / 10	335 / 10	335 / 10	335 / 10	335 / 10
Wheel bolt length	93	93	93	93	93	93	93	93
max. clamping length	29	29	not possible because of wheel seat hub	28	29	29	not possible because of wheel seat hub	29
Wheel nut	Standard		Standard	Standard		Standard		Standard
Wheel	Steel	Aluminium	Steel	Aluminium	Steel	Aluminium	Steel	Aluminium

	TS 2 3709 ET=0			SN 3620				
	S	Z		S	Z			
Wheel connection	275 / 8	275 / 8	275 / 8	275 / 8	275 / 8	275 / 8	225 / 10	225 / 10
Wheel bolt length	93	93	97	93	93	117	89	117
max. clamping length	27	27	52	27	27	52	26	54
Wheel nut	Standard		Standard	Shaft nut	Standard			Standard
Wheel	Steel	Aluminium	Steel	Aluminium	Steel	Aluminium	Steel	Aluminium

	SN 3020		
	S	Z	
Wheel connection	225 / 10	225 / 10	225 / 10
Wheel bolt length	93	93	117
max. clamping length	26	26	54
Wheel nut	Standard		
Wheel	Steel	Aluminium	Aluminium

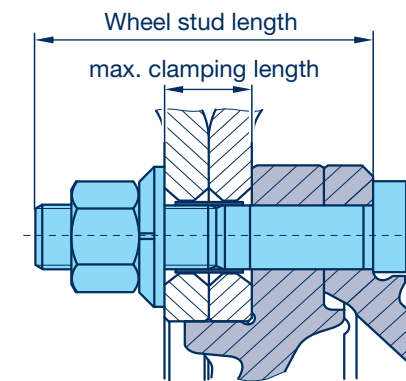
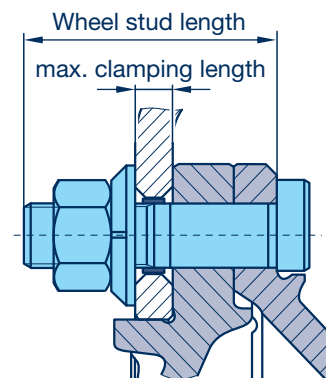

2.3.4 Standard axles ECO Plus 3 | 10 - 12 t

	TS 2 ET=0 (3709 and 4309, max. 10 t)				SN 4220			
	S		Z		S		Z	
Single / Twin	S		Z		S		Z	
Wheel connection	335 / 10	335 / 10	335 / 10	335 / 10	335 / 10	335 / 10	335 / 10	335 / 10
Wheel bolt length	89	97	97	97	89	97	97	117
max. clamping length	25	32	32	54	24	31	31	52
Wheel nut	Standard		Standard	Shaft nut	Standard		Standard	
Wheel	Steel	Aluminium	Steel	Aluminium	Steel	Aluminium	Steel	Aluminium

	TS 2 ET=0 (3709, max. 10 t)				SN 3620					
	S		Z		S		Z			
Single / Twin	S		Z		S		Z			
Wheel connection	275 / 8	275 / 8	275 / 8	275 / 8	275 / 8	275 / 8	275 / 8	275 / 8	225 / 10	225 / 10
Wheel bolt length	89	97	97	97	89	97	97	117	97	117
max. clamping length	25	32	32	54	26	33	33	54	33	48
Wheel nut	Standard		Standard	Shaft nut	Standard		Standard			
Wheel	Steel	Aluminium	Steel	Aluminium	Steel	Aluminium	Steel	Aluminium	Steel	Aluminium

	SN 3020	
Single / Twin	Z	
Wheel connection	225 / 10	225 / 10
Wheel bolt length	97	117
max. clamping length	33	48
Wheel nut	Standard	
Wheel	Steel	Aluminium

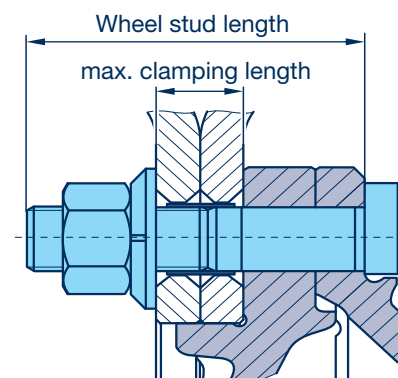
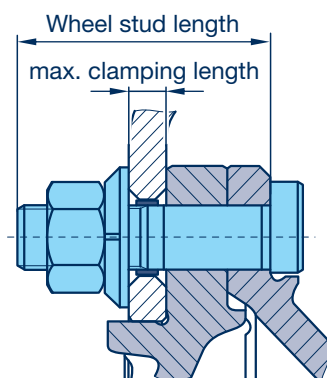

2.4 Self-steering axles

2.4.1 Reasons for use; VECTO Bonus

In general, steering axles make it possible to comply with the legal requirements (e.g. 97/27/EC Annex I) when driving in circles or around corners (Swedish Corner). This is particularly important for large wheelbases (distance between kingpin and center of axle unit). With lifted trailer front axles (picture on the right), this wheelbase is extended.

Other reasons and advantages of steering axles:

- Better manoeuvrability and reduced road space requirement.
- Reduction of rolling resistance, resulting in longer tyre life and uniform tyre wear on all axles.
- Lower fuel consumption of the motor vehicle, especially in regional and urban traffic. In the VECTO calculation (for O3 and O4 trailers or semitrailers with closed, box-shaped bodies), vehicles with steering axles therefore receive a bonus. For example, 3 % fuel consumption is accounted for in the case of three-axle trailers in regional traffic, and 4.5 % in urban traffic. With additional use of axle lifts, this bonus increases again.
- Protection of vehicle and road surface due to reduced lateral forces on the wheels, avoidance of collision damage to tyres and roadside barrier.

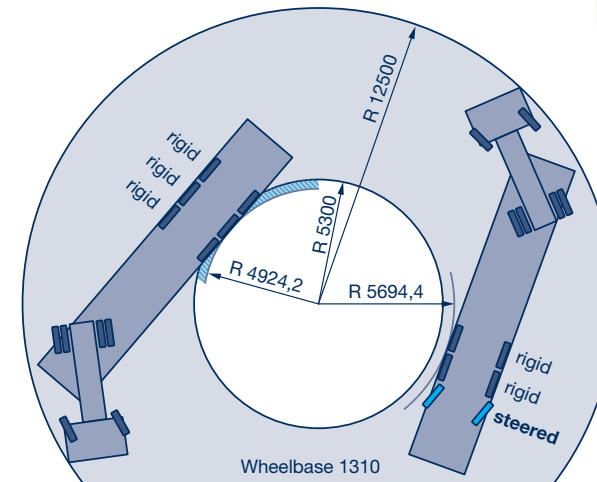

Semi trailer without lift axle

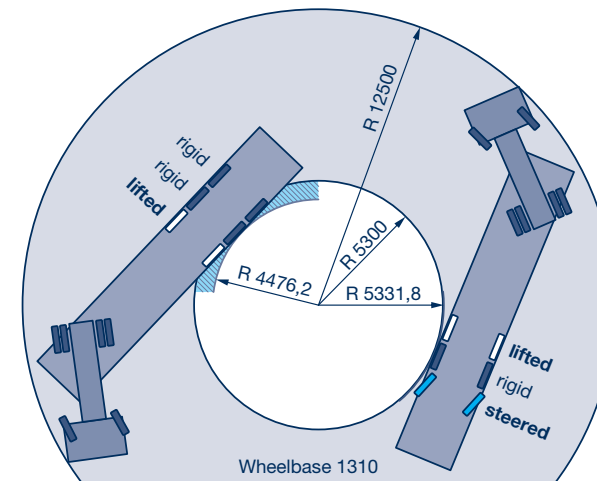

Semi trailer with lift axle

2.4.2 Functional principle of undulated pressure disc, expert opinion

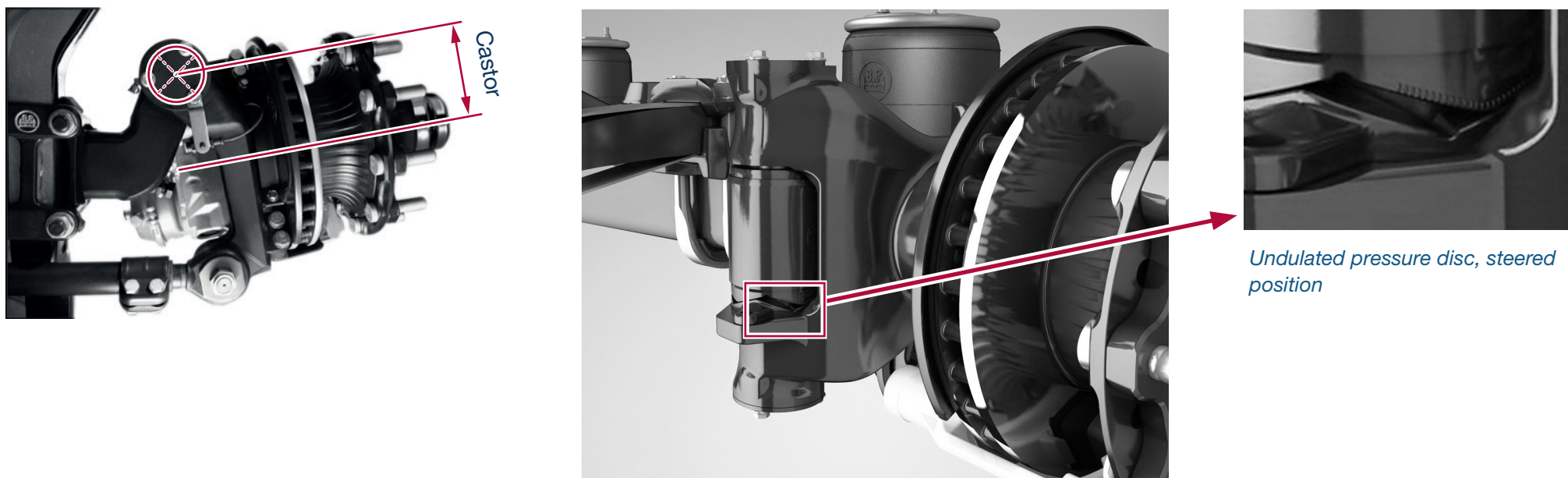

Due to the design castor (150 mm), the steering is triggered by lateral forces on the rolling wheel when driving forward in a curve (friction steering). The eponymous load-dependent steering stabilization (LL) is realized by undulated pressure discs. The steering movement is thus superimposed by a lifting movement that ensures straight-line stability again after cornering.

Use of the self-steering axle in the trailer: According to ECE-R79 section 5.2.1 always to be combined with at least one rigid or positively steered axle according to RDW expert opinion.

[RDW expert opinion](#)

2.4.3 Reversing

- A pneumatic locking cylinder actuates a spring-loaded bolt which, when depressurized, connects the axle beam and track rod in the straight-ahead position without play (steering lock). Compressed air in the locking cylinder (signal via EBS and reversing light) moves this latch and unlocks the steering function.
- When reversing, monitoring of the reversing light in the EBS locks the steering axle. For maximum driving stability at high speed, additional speed-dependent locking (parameterization in EBS, e.g., from 30 km/h) is possible.
- The locking cylinder is mounted from above at the factory. Mounting from below requires approval by BPW.
- On a consolidated surface, a self-steering axle in steered position usually passes through the straight-ahead position having reversed for a few metres, meaning that the pretensioned lock engages.

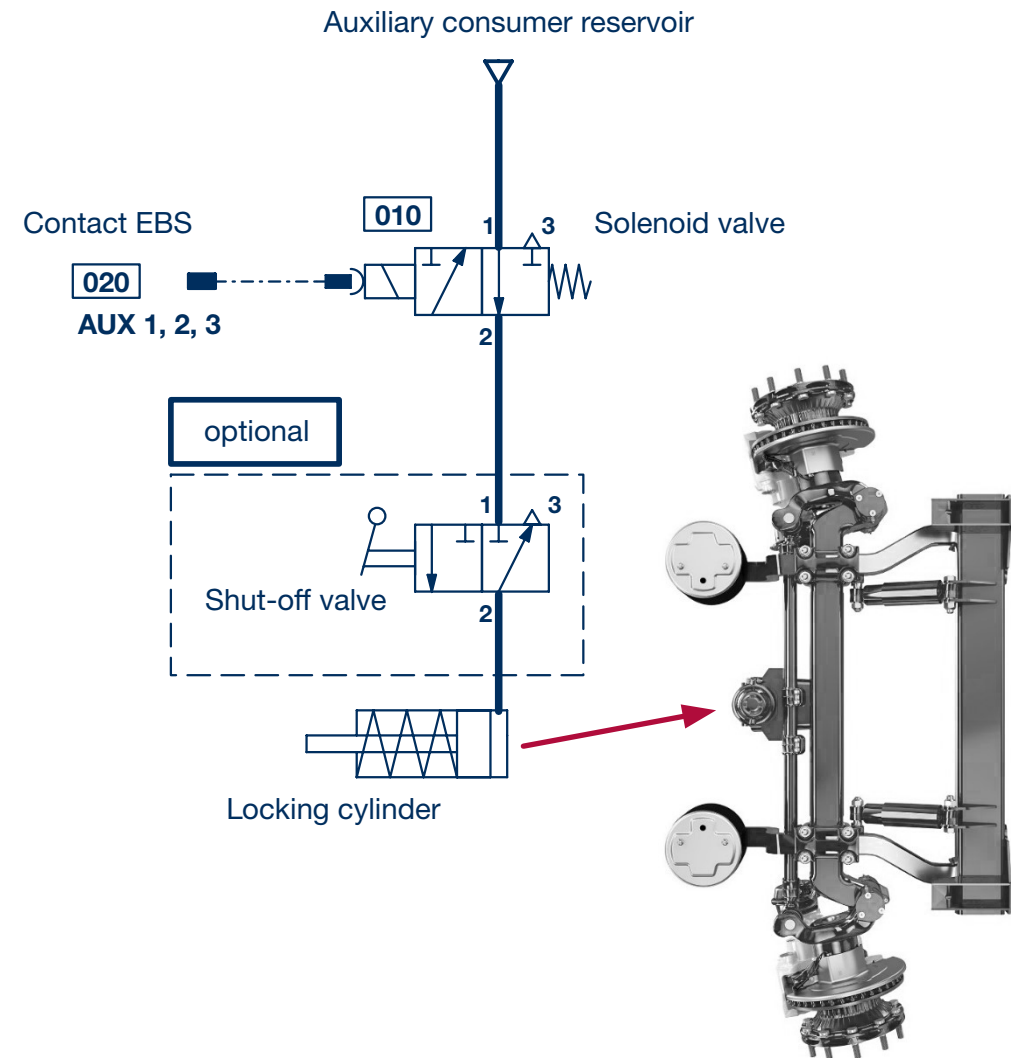

2.4.4 Auxiliary steering with ARC (Active Reverse Control)

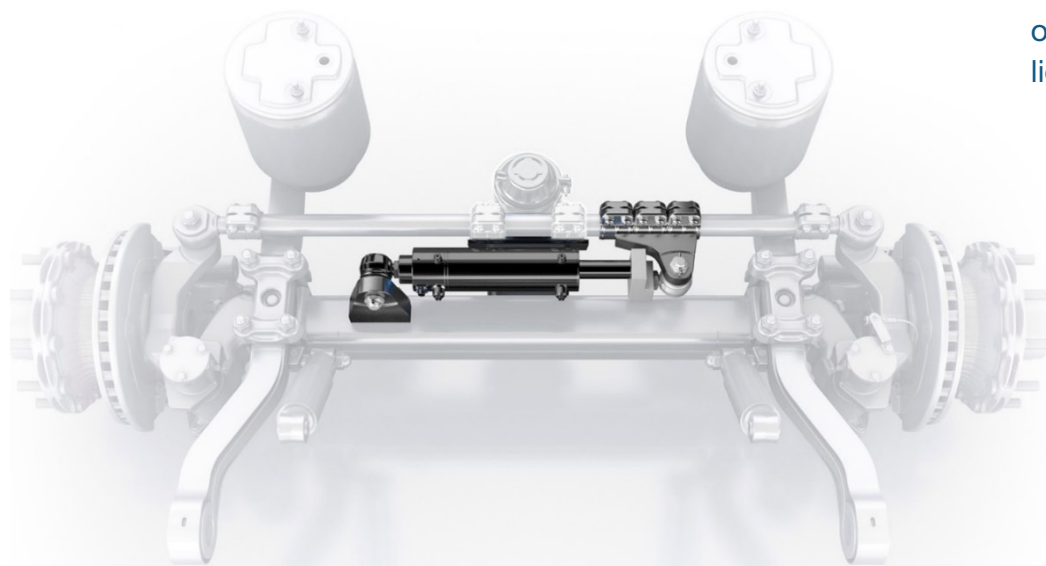

The optional electrohydraulic plug-and-play system ARC automatically ensures the correct steering angle in every situation. The locking cylinder is only required in the event of a malfunction of the ARC (manual on / off switch). The switching signal comes via the EBS or the reversing light.

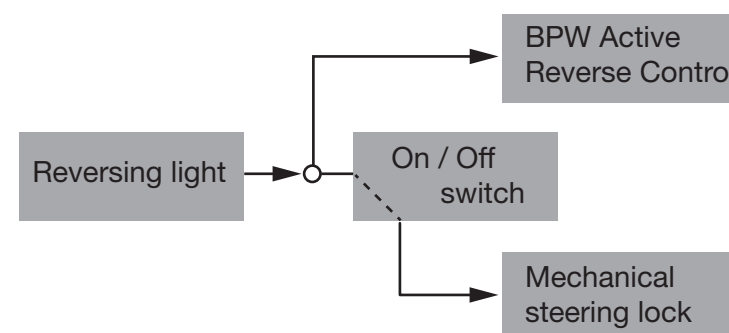

2.4.5 Steering angle and limitation

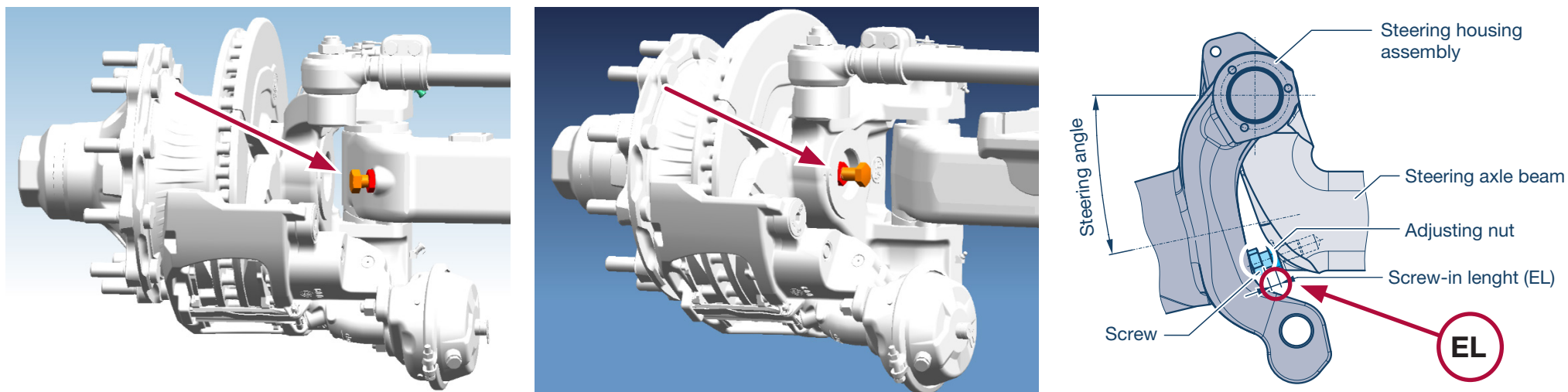

BPW self-steering axles are designed for steering angles of up to 20°. A special axle beam shape is optionally available that allows a steering angle of up to 27° (only for square 120 solid).

On axles for 20° steering angle, the limitation is realized directly via the contact between the steering housing and the steering knuckle; an adjusting screw is then not included in the scope of delivery (exceptions K...LL and TSB 4312).

For all other versions, an M20 x 1.5 stop screw is mounted either on the axle beam (left picture) or on the spindle (center picture). This means that the steering angle is set in accordance with the order ex works, but can also be changed subsequently (e.g. if there is a lack of clearance for the pivoting wheels). On request, BPW will provide assembly drawings with reference of the screw-in length (EL) to the steering angle (example on the right).

2.4.6 Steering damper

- Retrofittable solution for damping steering vibrations
- up to 23° steering angle
- Simple and quick mounting due to screw solution and two-piece clamp
- Various parts sets available depending on axle and unit design

Application recommended for:

- equal number of rigid axles and steering axles in the trailer (1:1) or when using an axle lift in the triple-axle unit
- Where steering axle king pin bearings are connected to a central lubrication system
- Vehicles with high centers of gravity and large wheelbases

The use of steering dampers can be dispensed with when using an automatic speed-dependent locking function (switched by EBS).

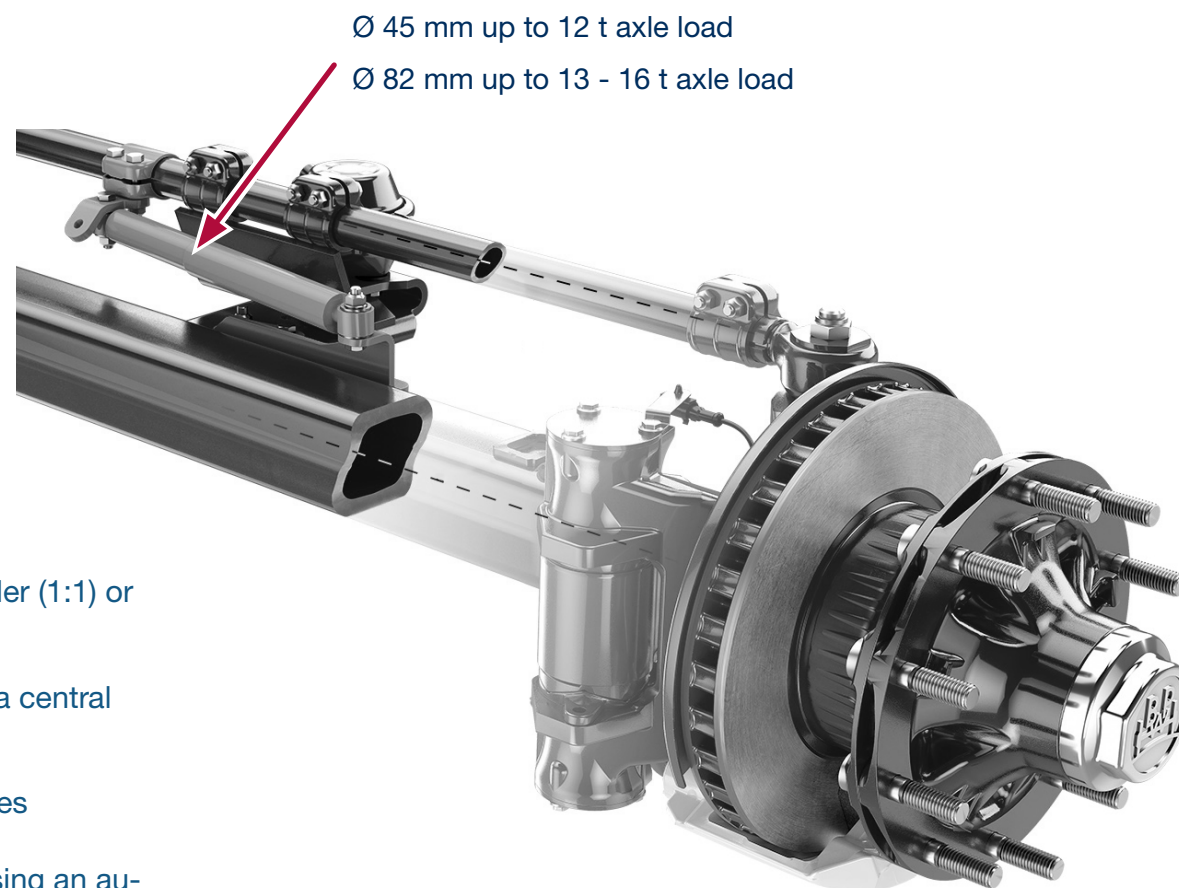

2.4.7 Installation angular position at nominal ride height

Setting the nominal driving height changes the angular position of the axle and thus the castor on the ground. BPW therefore recommends the following restriction for the best possible function of the steering system:

H / M.....LL, 22.5" wheels: **0 to +7°**

NH / NM.....LL, 17.5" Wheels: **0 to +10°**

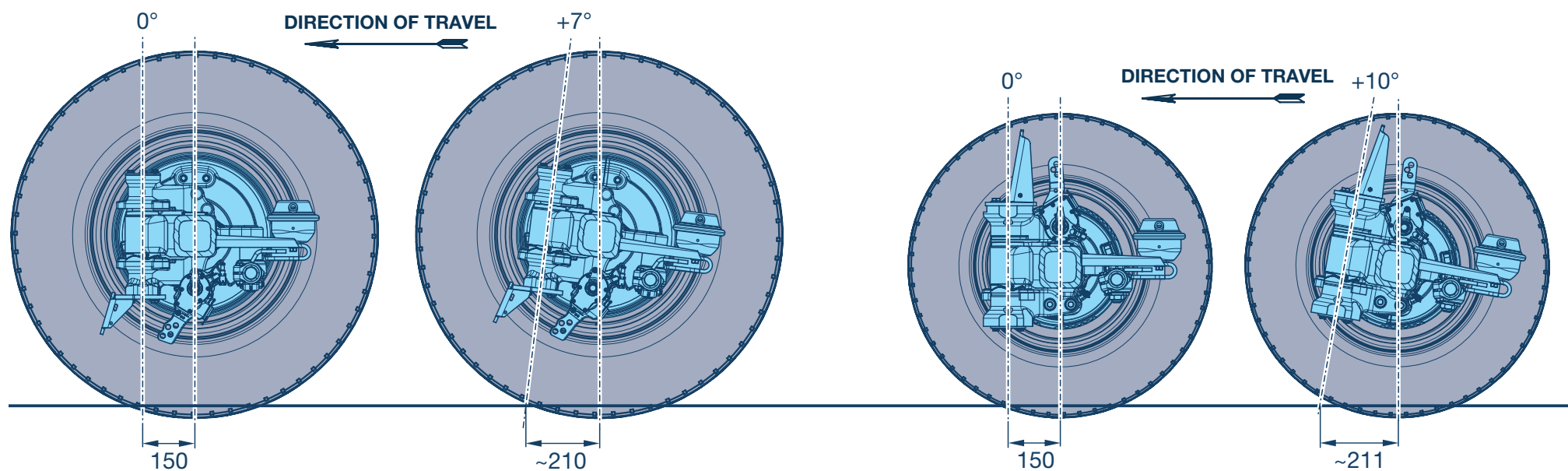

2.4.8 Optimized installation in the unit (3D Trailing arm, Channel crossmember)

Due to the space required for the steering wheels at the rear, the distance between the two air bags must be smaller than for rigid axles. However, the forward offset steering center (castor) also means that this additional installation space requirement in the front wheel area is less.

- Due to the BPW 3D trailing arm, the spring center at the hanger bracket is 2 x 110 mm wider than at the axle. The longitudinal members of the vehicle frame can thus be built without lateral offset in many cases.
- BPW offers a channel crossmember as an alternative or in addition in order to realize a further offset between the spring center hanger bracket and the chassis frame center. A shock absorber connection is then also integrated.
- The design of the self-steering axle usually determines the entire axle unit. BPW therefore requires the following information for optimum design: Axle load, brake and trailing arm design (ride height), tyre and wheel size, chassis frame center, desired steering angle, maximum overall width over the tyres.

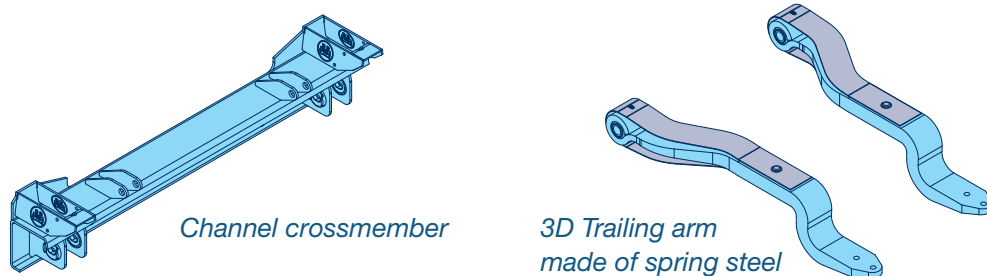
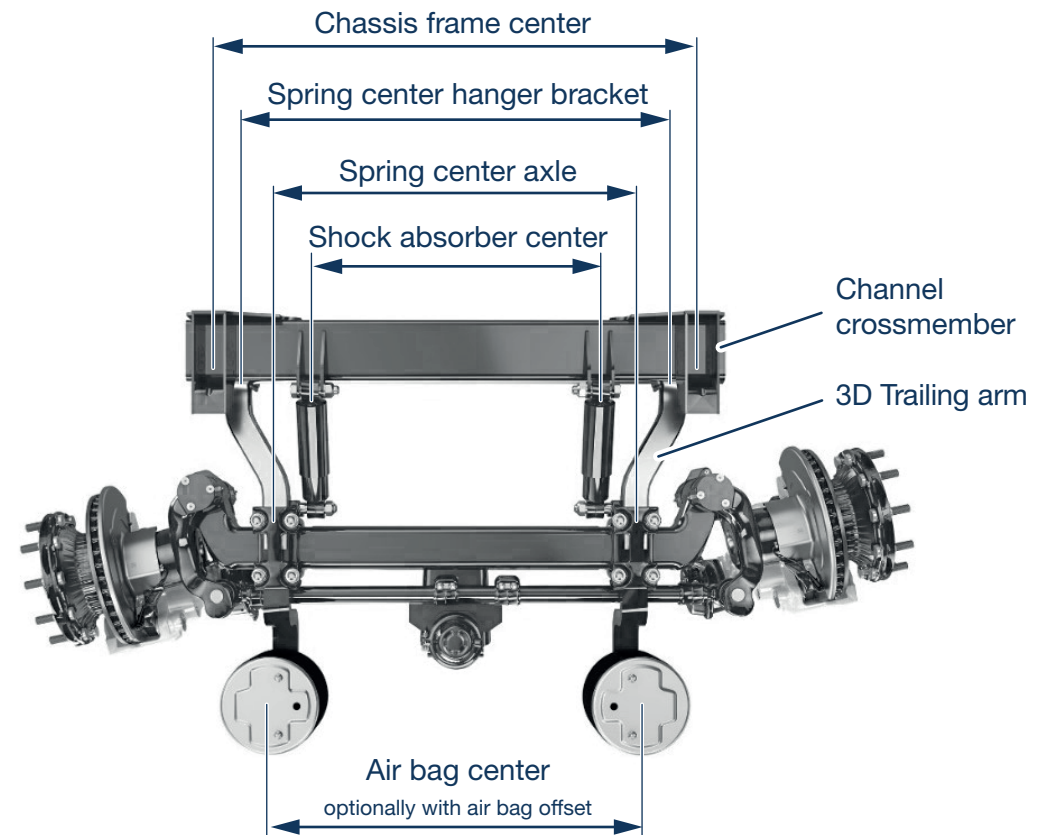

2.5 Forced steering axles

2.5.1 Advantages and operating principle

The advantages described in 2.4.1 also apply to forced steering axles, as does the VECTO bonus.

Unlike self-steering axles, however, these have no offset in the longitudinal direction between the axis of rotation of the steering housing and the center of the wheel. The steering must be operated by a steering system (mechanical or hydraulic) (forced steering).

- Characteristic geometric features are: Track, steering bolt center, spring center, steering angle
- The steering roll radius (*track minus steering bolt center*) : 2) determines the installation space required for the steering wheels.
- The steering lever geometry (length, angular position, cranking) determines the position and length of the steering rod.
- BPW requires the following information for optimum design: Axle load, brake and spring design (ride height), tyre and wheel size, chassis frame center, desired steering angle, maximum overall width over the tyres, intended steering system.

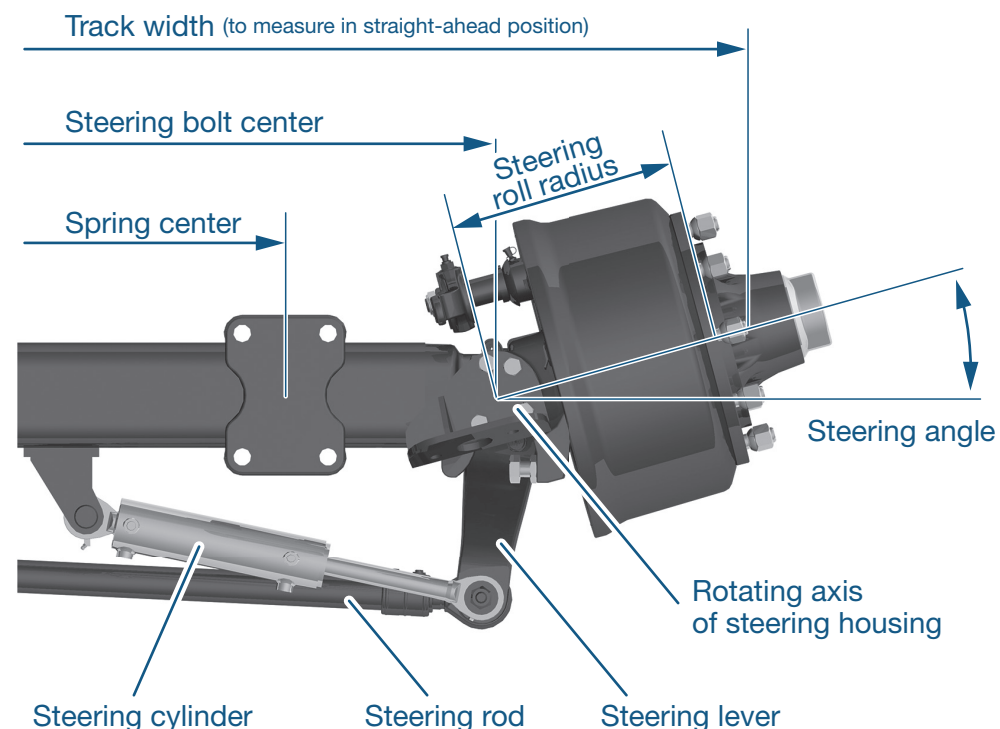

2.5.2 Variants of important details

Option pre-assembly of suitable brake cylinders
(for lever lengths 150 or 165 mm)

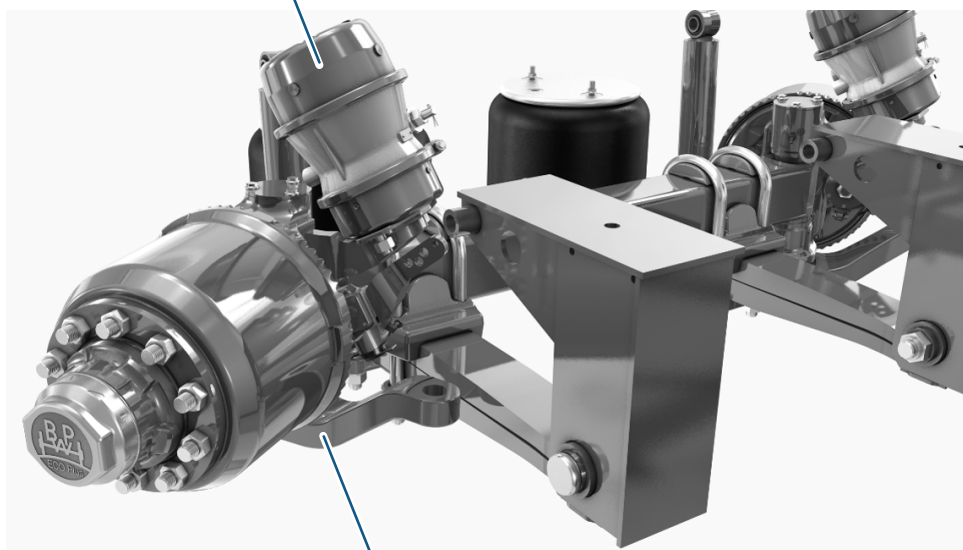

Steering levers in various lengths (300...420 mm), offsets (70...170 mm) and angular positions (0...13°), to match the suspension unit and the steering system

Standing base plates for different brake cylinder positions

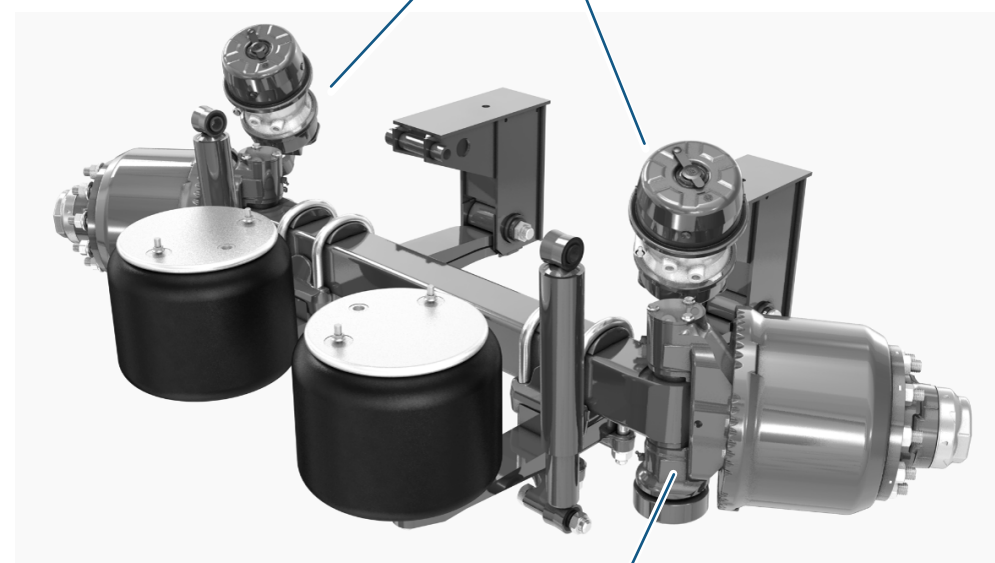

Steering angle max. 35° (square 150 solid) or 34° (square 120 solid).

Optional axle beams for steering angles up to 45° also available for this purpose

2.5.3 Installation of angular position at nominal ride height

Adjusting the nominal ride height changes the geometries and forces in the steering system. This is because the wheels make an additional lifting movement during steering when the axle has an angular position. BPW recommends the following upper limits:

H / M.....L, 22.5" wheels: **-5 to +5°**

NH / NM.....L, 17.5" wheels: **-7 to +7°**

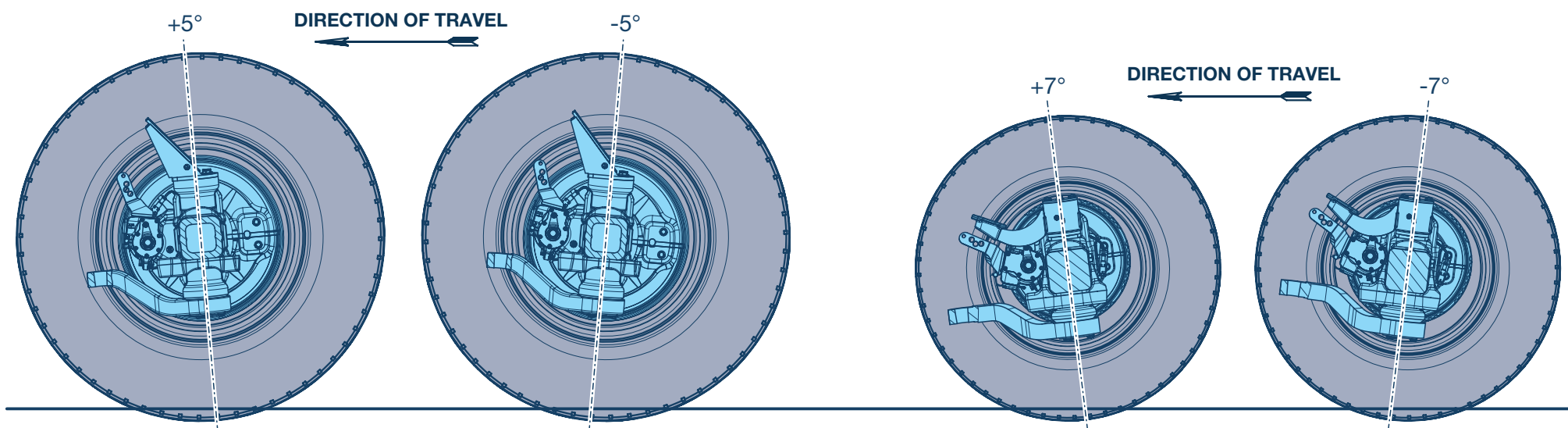

2.6 Stub axles

2.6.1 Application, features, advantages

- When transporting heavy and bulky loads such as large glass panes or precast concrete parts, in-loader trailers have proven their worth. BPW stub axles are suspended on trailing arm swinging links on the vehicle side (not supplied by BPW), which have air or hydraulic suspension.
- The compact design with particularly narrow drum brakes and wheels with a defined offset allows maximum use of the free space in the interior for the load
- In addition to the maintenance-friendly ECO-Plus bearings, detail optimizations such as particularly high-quality sealing of the brake camshafts ensure a long service life for the running gears
- BPW also offers stub axles as customized solutions for special applications such as the transport of cable drums, in order to achieve the greatest possible design scope in the chassis

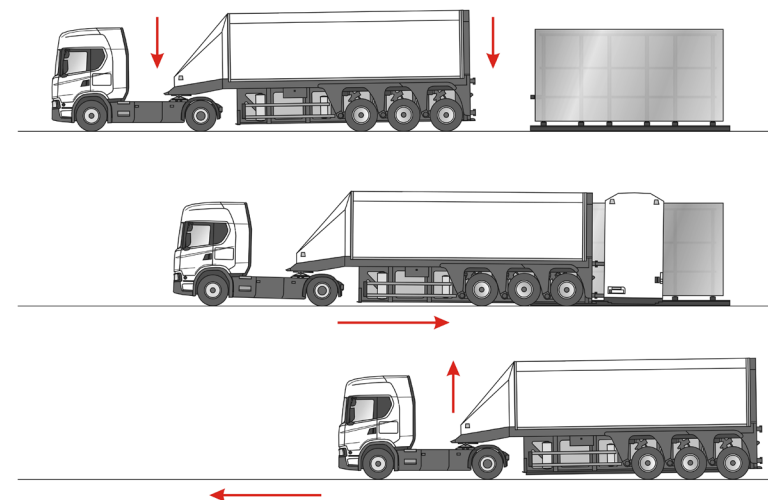

Source: Company Faymonville

2.7 Swing axes

2.7.1 Functional principle

- In vehicles with swing-mounted oscillating axes, the load is transferred particularly evenly to the road surface. In conjunction with hydraulic axle compensation, optimum distribution of axle loads is ensured even in the case of major unevenness or long vehicle units.

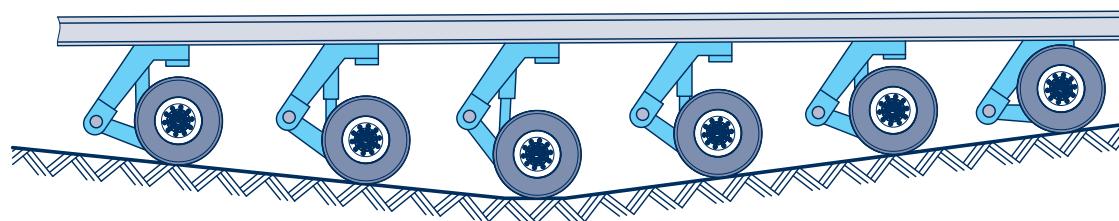
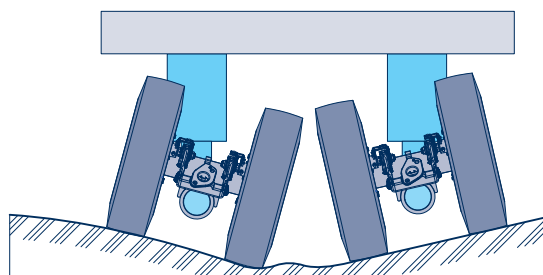

- Due to the road-saving design of these split axes, the legislator grants higher axle loads (e.g. in Germany 12 t per axle line, i.e. two swing axes) compared with rigid axle designs (in Germany max. 10 t per axle).

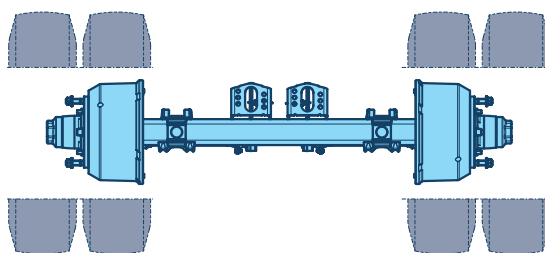

↑
10 t

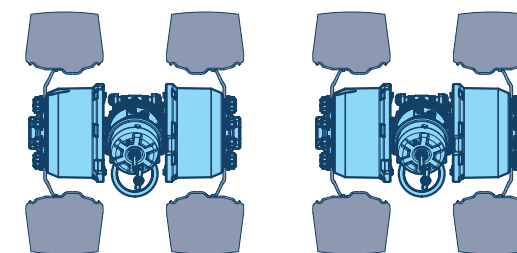

↑
2 x 6 t = 12 t

2.7.2 Construction

- In swing axles, the two brakes of the axle are actuated by only one brake cylinder for reasons of installation space. The even distribution of the braking force is achieved by means of a brake balance.
- Diaphragm cylinders type 30 or spring accumulators type 30/30 at the lever connection 180 mm are predominantly used.
- The swing bale welded to the axle beam forms the pivot joint with the swing axle rocker (not supplied by BPW).

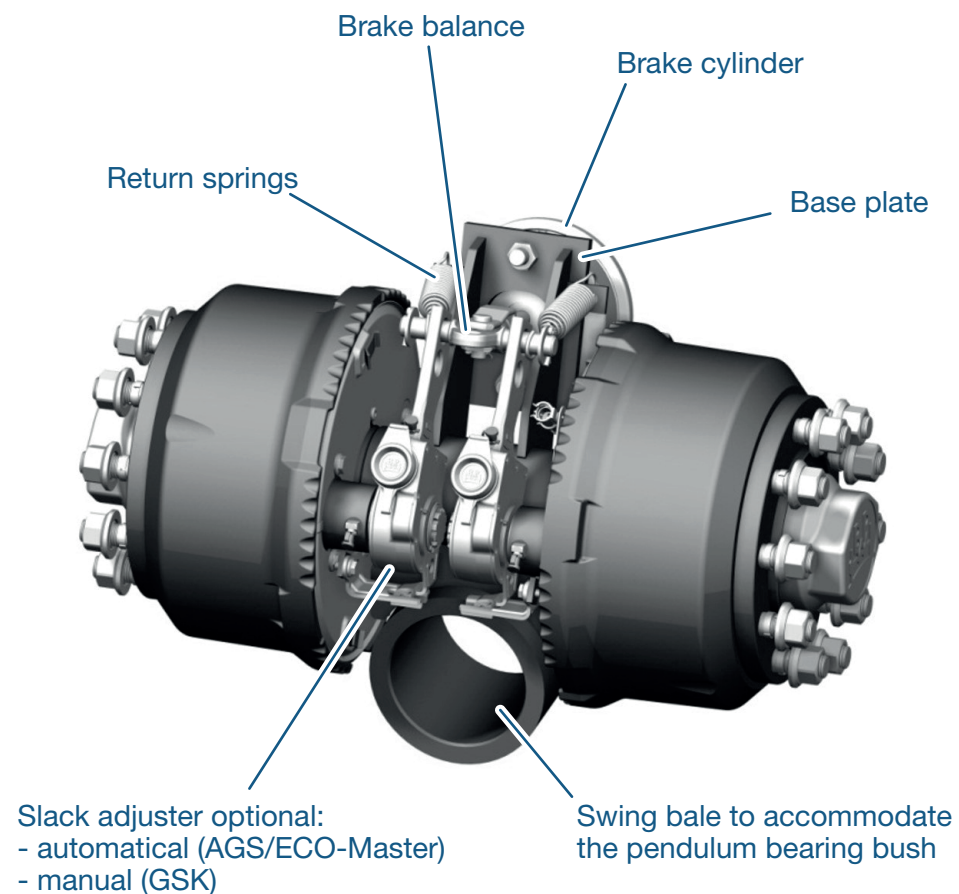

2.7.3 Single tyres, offset and track width

- The choice of tyres determines the axle load, track width and wheel end of the swing axle.
- Special wheel hub (called B-hub) for wheels with offset
- Hub cap and wheel bolts do not protrude beyond the outer edge of the tyre.

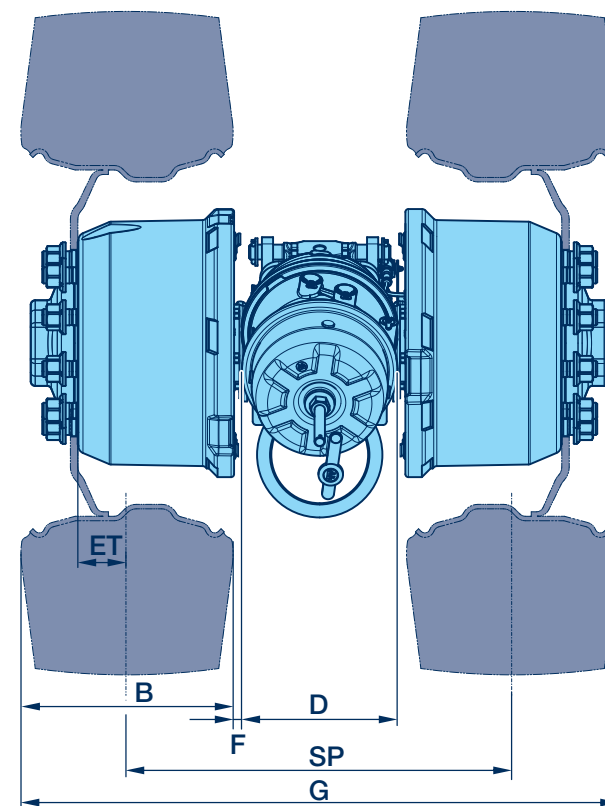

Examples of single tyres:

Tyre	Track SP	Tire Width B	Offset ET	Ø Brake cylinder D	Overall width G	Clearance F	Axle load	Application
245/70 R17.5	494	241	55	209	735	22	6 t	NRDBMP 6010
245/70 R17.5	540	241	55	209	781	45	6 t	NRDVBMP 7010
285/70 R19.5	518	285	66	209	803	12	7t	

2.7.4 Twin wheels and track width

- The choice of tyres determines the axle load, track width and wheel end of the swing axle.
- ECO Plus wheel hubs and bearing technology of the BPW series axles are used for twin tyres.

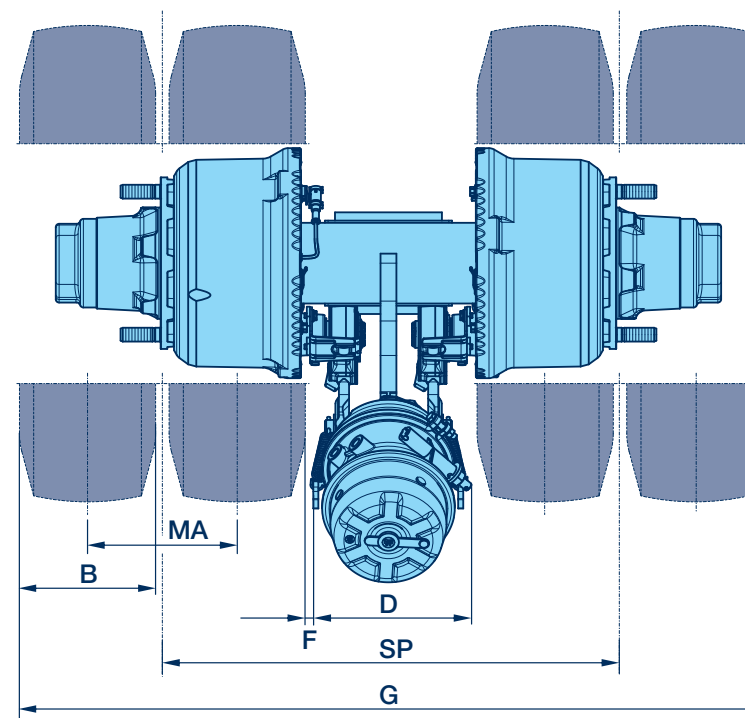

Examples of twin tyres:

Tyre	Track SP	Tyre Width B	Center distance MA	Ø Brake cylinder D	Overall width G	Clearance F	Axle load	Application
215/70 R17.5	735	221	248	209	1204	28.5	12t	NRZFP 12010
235/70 R17.5	790	241	280	209	1312	30	12t	NRZFP 12010

2.8 Additional equipment

2.8.1 Odometer ECOMETER

With the ECOMETER, BPW offers hub caps with an integrated mechanical odometer.

[Installation instructions ECOMETER](#)

ECOMETER

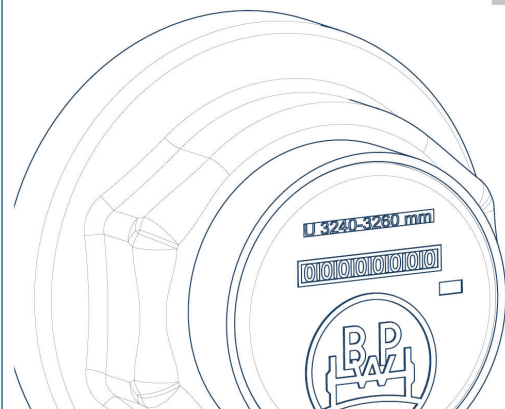

04.001.21.26.0

Montagehinweis · Radkapsel mit integriertem Kilometerzähler

Installation order · Hub cap with integrated mileage counter

Directive de montage · Capuchons avec compteur kilométrique intégré



BPW-EA-ECOMETER 37291701

we think transport 

2.8.1 Odometer ECOMETER | Overview mechanical ECOMETER for 6.5 - 12 t axle load

Consec. no.	ECO Plus 3 6.5 up to 9 t	ECO Plus 3 10 up to 12 t	Rolling circumference	Tyre size exemplary
1	05.212.75.10.0	05.212.75.52.0	2170	205/65 R17.5
2	05.212.75.11.0	05.212.75.53.0	2350	215/75 R17.5
3	05.212.75.12.0	05.212.75.54.0	2425	235/75 R17.5 245/70 R17.5
4	05.212.75.13.0	05.212.75.55.0	2560	9.50 R17.5 8.25 R15 245/70 R19.5
5	05.212.75.14.0	05.212.75.56.0	2620-2650	265/70 R19.5
6	05.212.75.15.0	05.212.75.57.0	2712-2750	285/70 R19.5
7	05.212.75.16.0	05.212.75.58.0	2730-2790	445/45 R19.5
8	05.212.75.17.0	05.212.75.46.0	2830-2860	255/70 R22.5
9	05.212.75.18.0	05.212.75.47.0	2915	275/70 R22.5
10	05.212.75.19.0	05.212.75.59.0	2960	425/55 R19.5
11	05.212.75.20.0	05.212.75.48.0	3015-3134	315/70 R22.5
12	05.212.75.21.0	05.212.75.49.0	3175-3220	10.00 R20 11.00 R22.5
13	05.212.75.22.0	05.212.75.50.0	3240-3260	385/65 R22.5
14	05.212.75.23.0	05.212.75.51.0	3280-3310	12.00 R22.5 365/80 R20
15	05.212.75.24.0	05.212.75.60.0	3410-3470	425/65 R22.5 13.00 R22.5
16	05.212.75.25.0	05.212.75.61.0	3505	445/65 R22.5

2.8.2 Tyre pressure monitoring system TPMS

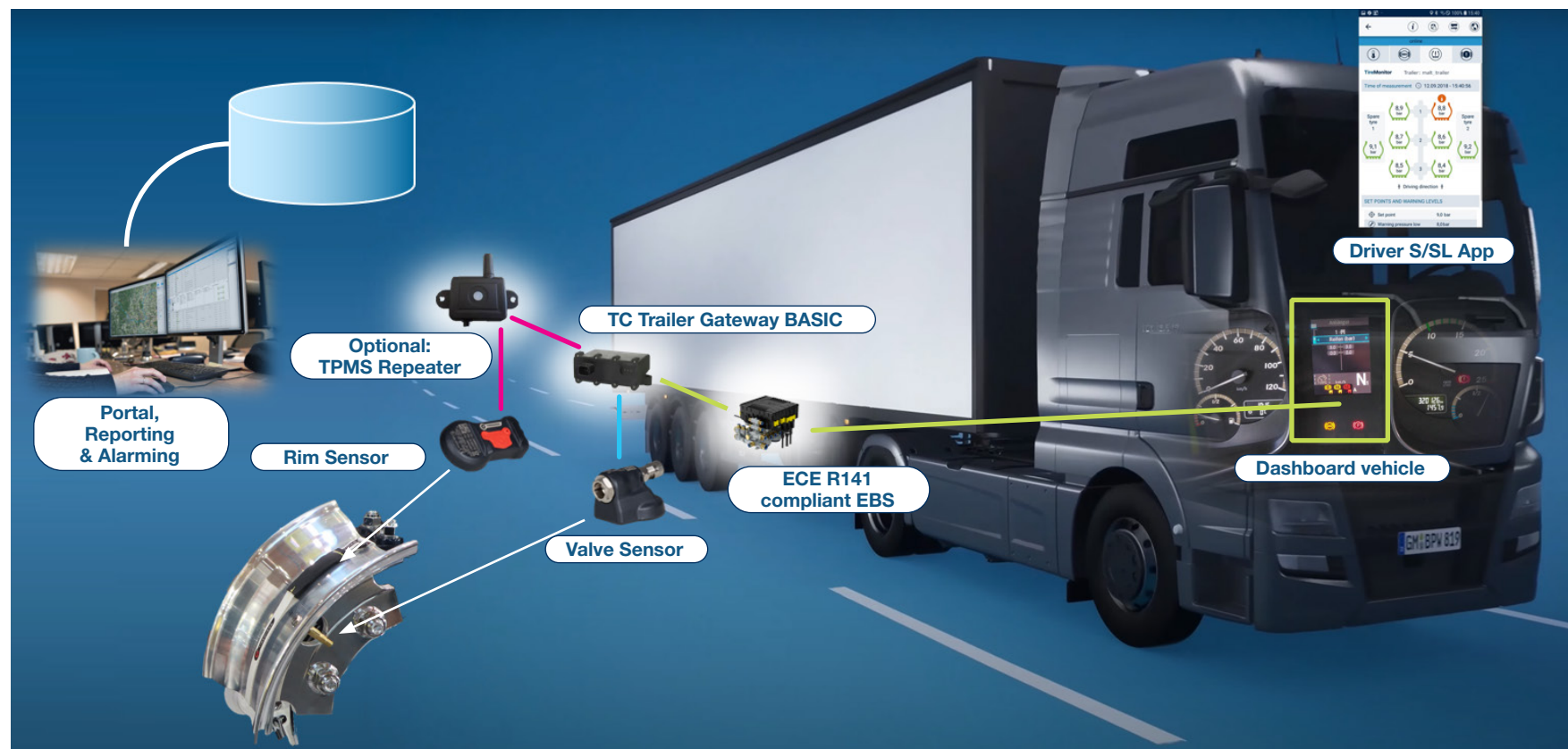

Through its subsidiary idem telematics, BPW offers the TPMS (Tire Pressure Monitoring System) wheel sensor system for recording tyre pressure and temperature for connection to the telematics system.

[Installation manual and CE Declaration Trailer Gateway BASIC](#)

2.8.3 Tyre pressure control system AirSave

With AirSave (a Tyre Pressure Regulation System / TPRS), BPW offers the tyre pressure regulation system including connection to telematics. The tyre pressure of each connected wheel is thus kept constant. Even though not every single tyre pressure is recorded here - as with the TireMonitor Hub - AirSave fulfills the legal requirements (e. g. ECE R141) of automatic tyre pressure monitoring with direct driver information via the dashboard.

[Installation and operating instruction AirSave](#)

[AirSave on youtube](#)

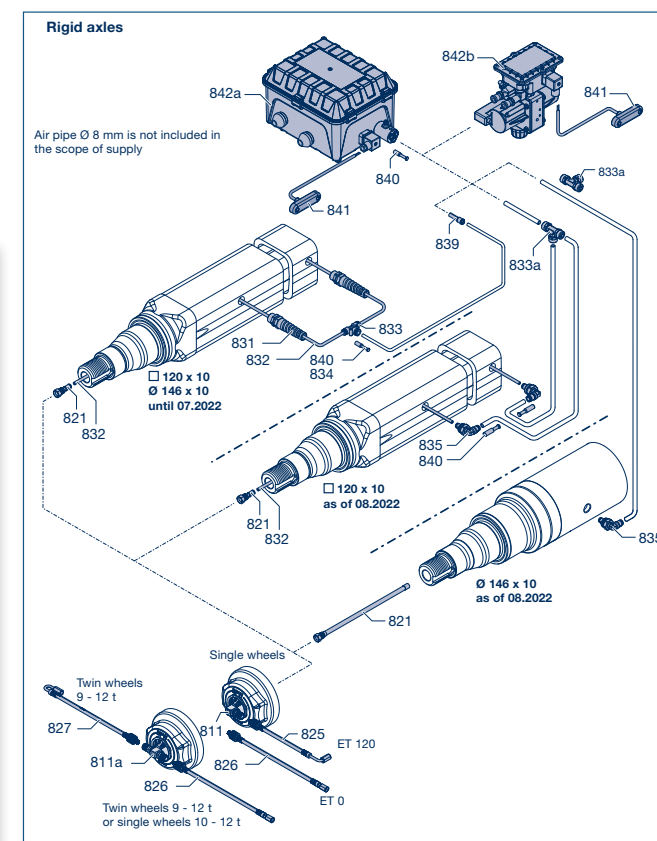
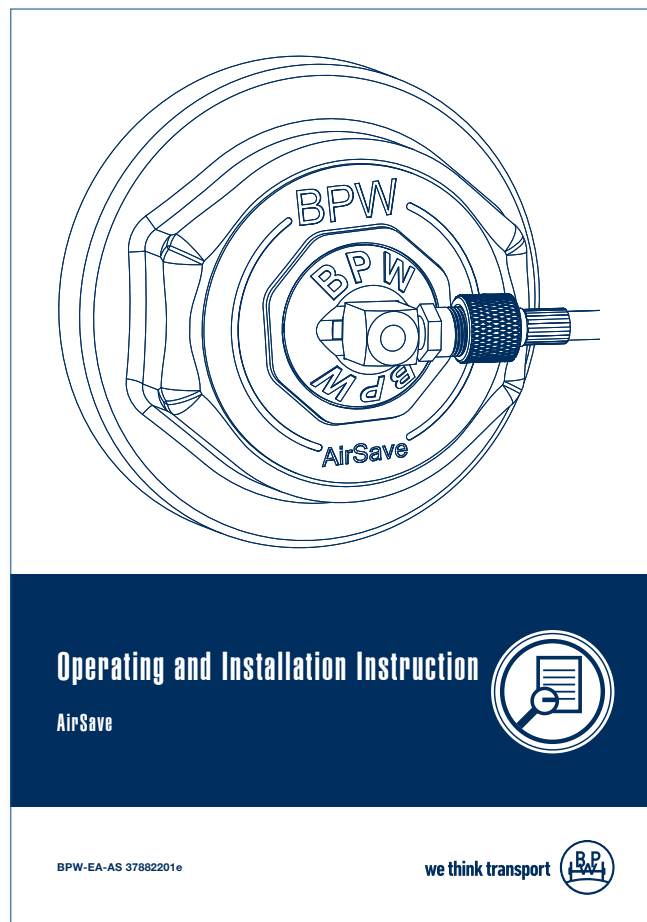

2.8.4 Electrohydraulic auxiliary steering Active Reverse Control (ARC)

With Active Reverse Control (ARC), BPW offers a pre-installed electro-hydraulic auxiliary steering system (for forwards and reverse) for BPW self-steering axles. An additional steering angle sensor on the fifth wheel coupling is not required.

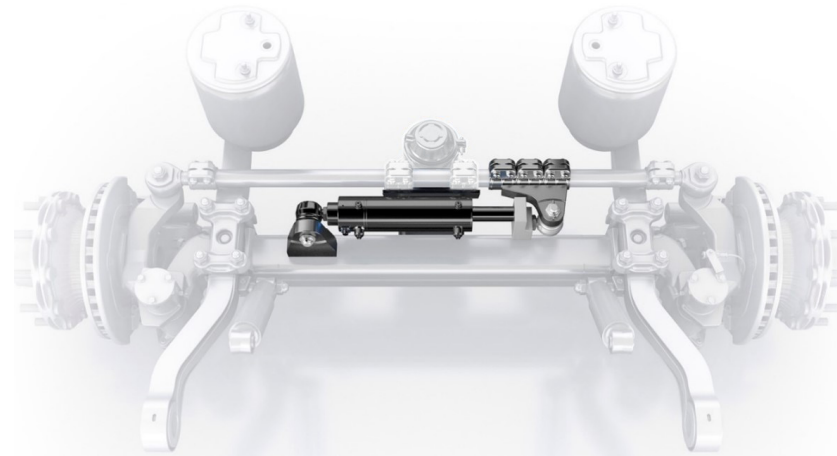

[ARC operating instructions](#)

[ARC Installation and operating instruction](#)

[ARC-App operating instructions](#)



Bedienungsanleitung /
Operating instructions /
Instructions d'utilisation /
Инструкция по эксплуатации

Active Reverse Control

BPW-BA-ARC 37502101606 - 04.001.21.48.0

we think transport

Installation and
operating instructions

Active Reverse Control

BPW-EA-ARC 377620016

we think transport

Operating instructions

Active Reverse Control - APP

BPW-BA-ARC APP 379420004

we think transport

TÜV Rheinland Group

Vizsgálati jelentés száma/Test Report No. : A-1226918R111

Típus / Type : RS Trailer / BPW Active Reverse Control

Össztípus / Manufacturer : BPW Hungary

VIZSGÁLATI JELENTÉS/TEST REPORT

Az Egyenlítő Hengerek Európai Gazdasági Bizottságának (ENSZ-EGOB) 79. –
A járművek kormányberendezéseinek jóváhagyására vonatkozó egyetemes
rendelet 03. sz. módosítás
száma / according to
Regulation No 79 of the Economic Commission for Europe of the United Nations
(UNECE) – Uniform provisions concerning the approval of vehicles with regard to
steering equipment Addendum 79: Regulation No 79
03 series of amendments

A jóváhagyás időtartama/Periodically granted

EU típus-jóváhagyás/EU type – approval : n/a

ENSZ EOB jóváhagyás/UNECE approval : n/a

Vizsgálati jelentés kiadásának/Structure of the Test Report

Item No. : 0. Általános információk/General information

1. Vizsgálati jelentés/Technical Report (Tervezési változatok / design)
2. Vizsgálati naplósajátírt record
3. Tapasztalatszerzőlap / test record
4. Megfelelésnyilatkozat/Statement of conformity

A Vizsgálati jelentés teljes tartalmában csak az ügyfél szóbeli és írásbeli nyilatkozata.
Rechtslagen, módosítások és változásokon kívül csak a Motor és Szilárdsági Osztályban engedélyezett lehet.
The Test Report shall be reproduced and published in full by the client only. It shall however
be reproduced and published jointly with the written permission of the Testing Laboratory only.

TÜV Rheinland Kft. / 1115 Budapest / Telefon: +36 1 200980 / Fax: +36 1 203107 / TRL_BPW_79_KTL_KH2_HU_RP_16_006 / Page 1 of 6

2.8.4 Electrohydraulic auxiliary steering Active Reverse Control (ARC)

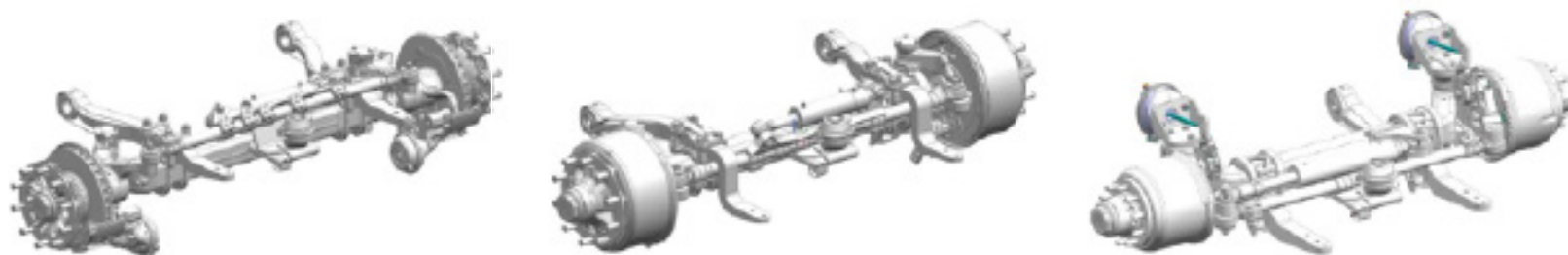

Axle series	TS2 Disc brake	SN 420 Drum brake	SN 3020 Drum brake
Tyres	R22.5 and R19.5	R22.5	R17.5
Offset	Offset 0 and offset 120	ET 0	ET 0
Single / Twin	Single tyre	Single and twin wheels	Single and twin wheels
Axle load	9 - 10 t	9 - 10 t	9 - 12 t
Suspension	ALO / ALM / ALMT / ALU	ALO / ALM / ALMT / ALU	AL
Steering angle	10° - 18°	10° - 18° LE	12° - 20°

2.8.5 Generator axle ePower

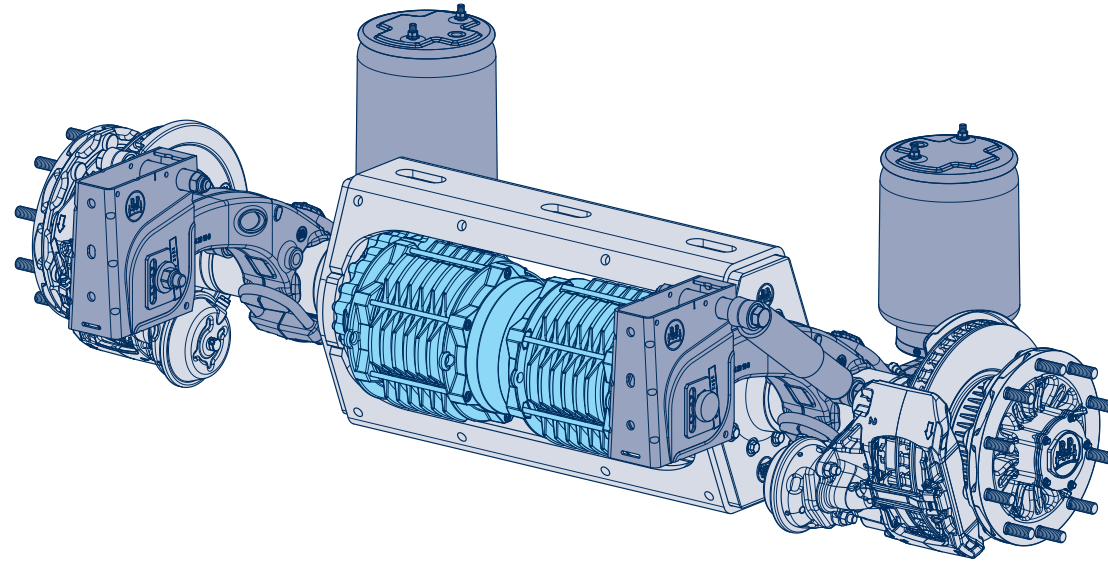

With ePower, BPW offers a trailer axle with integrated generator transmission units (GTU). These generate electricity for consumers in the trailer, e.g. for refrigeration machines, when driving downhill or decelerating the vehicle.

Technical data

- Generator power 2 x 5.5 kW nominal power (2 x 8 kW max. power)
- Axle load max. 9 t
- Recuperation from approx. 15 km/h (depending on tyre size)
- Wheelend 19.5" / 22.5", single tyres
- Disc brake TS2 3709 / 4309
- Axle weight approx. 750 kg (with generator/gearbox units)

When the axle is delivered, the so-called encoder cable is located inside the frame near the generators. Until commissioning and connection to the control electronics, the cable should remain here and must be protected from moisture.

Storage: The ePower axle must be protected from moisture due to electrical cable connections (encoder cable) as long as the final commissioning and thus the connection to the control electronics have not yet been made. Storage outdoors is thus not permitted.

Once the ePower axle has been mounted on the vehicle frame, the vehicle and thus the axle may be moved. As long as the HV connection to the control electronics is not established, no current flows.

2.8.5 Generator axle ePower | Installation and safety instructions

Installation instructions:

- The shock absorber must be mounted to the **exterior of the trailing arm**.
- The design of the vehicle must provide sufficient clearance above the ePower axle.
The ride height range must be 260 - 460 mm. No components such as air tanks or EBS may be installed 260 - 330 mm above the ePower axle.
- Installing an axle lift is not foreseen, as no electricity can be recuperated when the axle is lifted. It is in fact not possible to use an axle lift due to the higher weight of the ePower axle.
- The generator drive unit must be protected against damage during maintenance and transportation.
- The air spring valve shall be connected to the rear axle.

The air pipings must not be in contact with the axle beam or the GTU at travel level.

Safety instructions:

- Level 1 high voltage training is required for installation work.
- When carrying out installation work, the vehicle's high voltage supply must be disconnected and secured against being reconnected. Ensure that there is no power supply.
- Disconnect the negative (-) lead from the battery when carrying out electrical installation or welding work on the vehicle!
- Due to the offset centre of gravity of the ePower suspension unit, special care must be taken during handling and transportation (e.g. with a crane). If it "turns over", there is a risk of collision and injury.
- When installing ePower axles on the back, a small amount of oil may drip from the bleeder valve. Ensure that any dripping is caught.

2.8.5 Generator axle ePower | Mounting brake cylinder

When installing the brake cylinder on ePower axles with ECO Air suspension, ensure that there is sufficient clearance between it and neighbouring components.

For this reason, the brake cylinders are fitted in reverse. The compressed air connection extension must be at the front and point upwards.

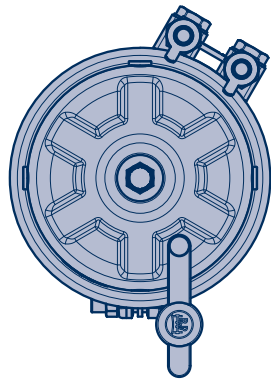

Version "A"
Even part number

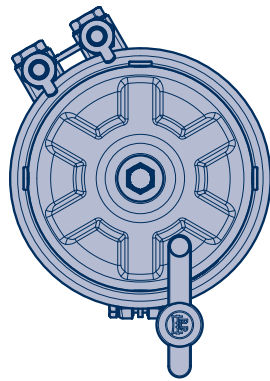

Version "B"
Odd part number



The air pipings of the brake cylinder must be routed in such a way that no damage can be caused by the axle beam.

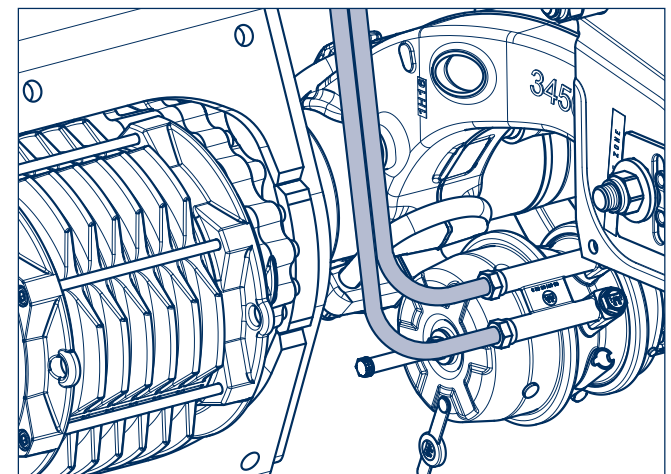
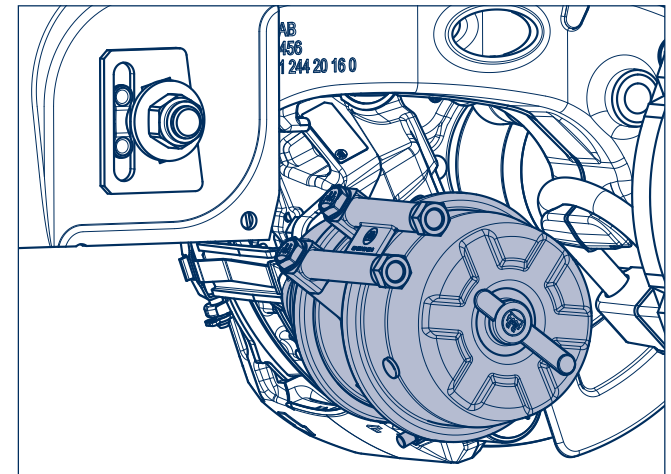

2.8.5 Generator axle ePower | ground clearance

When designing the running gear and selecting tyres, ensure that there is sufficient ground clearance as well as sufficient clearance between the brake disc and air suspension components.

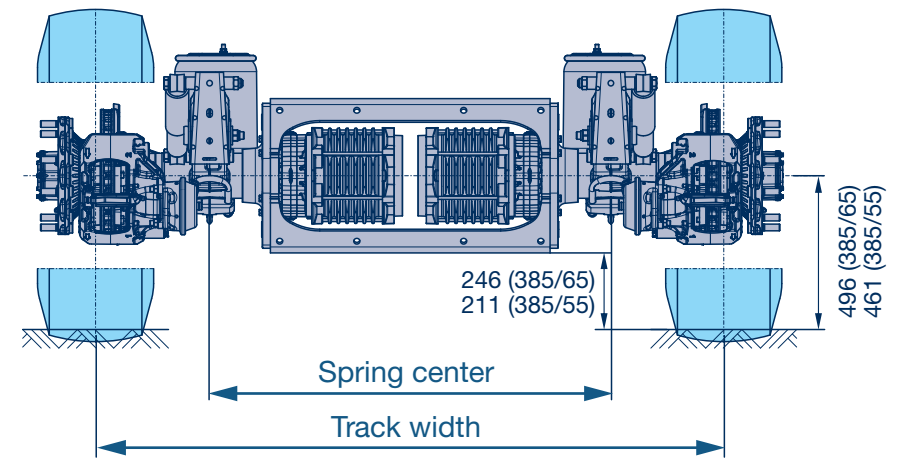

Possible track widths / spring centers for ePower:
2040 / 1300; 2095 / 1300; 2140 / 1400

2.8.6 Lightweight aluminum hub

9 t - axles with ECO Plus 3 wheel bearings are optionally available with forged aluminum hubs. This benefits weight-sensitive vehicles such as tankers or silo trailers. The high-strength alloy also allows use in the tipper.

- Weight reduction 18 kg / axle (54 kg / triple-axle unit)
- For air-suspended units with disc brake TS2 3709 / 4309 or drum brake SN 4218
- For single disc wheels Offset (ET) 0 for maximum lightweight construction
- Wheel connection 335 / 10
- With KTLzn coating and "Light" aluminum capsule
- In case of a subsequent retrofit, the track width of the axle is increased by 10 mm due to the thicker wheel flanges

Additional lightweight component LightTube [see page no. 203](#).



2.8.7 iC Plus running gear

The scope of delivery of the iC Plus smart running gear includes a 9-tonne standard unit equipped with pre-mounted brake pad wear sensors and the TC Trailer Gateway Basic telematics solution (optional Gateway PRO) from idem. In addition, 12 months of free telematics services are included in the cargofleet Trailer BASIC iC Plus tariff, which includes the following services:

- cargofleet Trailer BASIC Analyze Service
- cargofleet TyreMonitor Option
- cargofleet Maintenance Calendar Option

Functions of iC Plus

Brake Performance Monitor (BPM)

Intelligent algorithms provide information about the performance of the brake.

Brake pad wear sensing

Sensors provide information about the final wear of the brake pads.

TPMS / TPRS (Hardware required)

TPMS (Tyre Pressure Monitoring System) consists of individual sensors that continuously measure the tyre pressure. The TPRS (Tyre Pressure Refill System) AirSave also refills the tyres with air in the event of a pressure loss.

Axle load indicator

A digital display shows the current load on the axles and helps to ensure efficient utilisation of the vehicle.



Functions in cargofleet 3

Digital maintenance calendar

Display of maintenance dates; insight into the vehicle history

Digital maintenance management

Provision of chassis-specific maintenance instructions via an interface

Cargofleet 3

All-in-one telematics platform

Reporting on axle load, brake usage, tyre pressure and maintenance

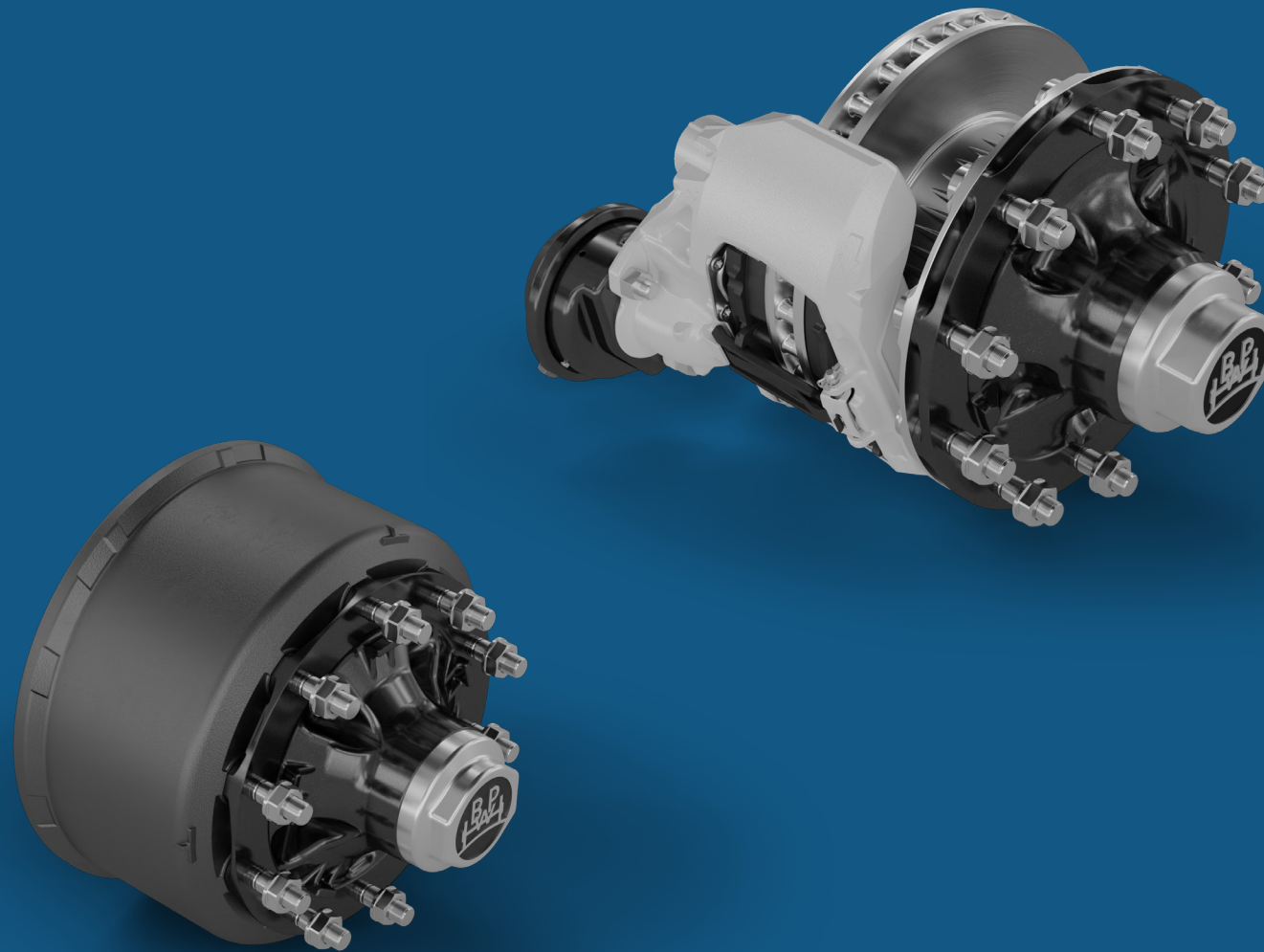

3

BRAKES

3.1 Design, test reports, calculation
3.2 Brake cylinder
3.3 ABS sensor, exciter ring

3.4 Base plates for drum brake axles
3.5 Slack adjuster ECO-Master
3.6 Drum brake ECO Drum

3.7 Disc brake ECO Disc
3.8 Disc and drum brake: operating instructions

3.1 Design, test reports, calculation

3.1.1 Brake system design

 Recommendations for performing UN R 13 brake calculations		TE - 4018.0E			
		2	Page	P.-No.	1
	Statutory requirement	BPW recommendation ...		E B S (electronic brakesystem)	
		Conventional brake-system		laden	unladen
Drawbar trailer	50 %	60 - 63%	the unladen condition is to aim	ca. 61,5 %	the unladen condition is to aim
Semitrailer	45 %	55 - 58%		ca. 56,5 %	
Centre axle trailer	50 %	60 - 63%		ca. 61,5 %	aim
General recommendations :					
<ul style="list-style-type: none"> The height of the centre of gravity stated by the vehicle manufacturer must be checked for plausibility and corrected following consultation if necessary. If the lever length is greater than 150 mm, make sure that only long-travel diaphragm cylinders are used. Long-travel cylinders must always be used with automatic slack adjusters. Overload protection valve must always be used with compressed- air brake system in combination with spring-type brake cylinder. The identification data of the BPW brakes please take form our technical information sheets TE-1498.0 and TE-2328.0 Basically the statutory regulations in UN R 13 are to be applied. 13 					
... Additionally for drawbar trailers:					
<ul style="list-style-type: none"> Front/rear equipment difference should always be kept as little as possible. The vehicle must be configured so that the braking effect on the rear axle does not fall below 50% given a theoretical tyre/road adhesion value of 0.8. 					
Valve setting:					
Lead: Should only be provided in exceptional circumstances when necessary in order to comply with statutory regulations. It should always be possible to achieve minimum braking with a 0 bar lead.					
ALB regulators: As a rule, 2 ALB regulators must be installed in drawbar trailers. Regulation of the ALB regulator in laden condition should only be undertaken in exceptional circumstances. Output pressures of $p_2 < 5$ bar at $p_m = 6.5$ bar should be avoided if possible.					
Adaption valve: The pressure retention should be set at the limit of the permitted statutory range (% P_e according to Appendix VII or lower limit of the configuration band).					
Articulated valve: Must be included under the following conditions, <u>if not before</u> :					
$\frac{\text{Front braking torque}}{\text{Rear braking torque}} \geq 1.2 \quad \text{for 3-axle trailer}$					
and					
$\frac{\text{Front braking torque}}{\text{Rear braking torque}} \geq 1.4 \quad \text{for 2-axle trailer}$					
		Date : 28.04.2023	Date : 03.05.2023		
		Name : KÖCHL.U	Name : PEHLE.M		
Version	13	Changes : 101803			

 Recommendations for performing UN R 13 brake calculations		TE - 4018.0E			
		2	Page	P.-No.	2
Setting parameters of EBS brake systems:					
Parameterization of EBS brake systems as follows:					
In SN-brakes (drum brake)					
- set pressure at $p_m = 0,8$ bar					
- deceleration empty vehicle = deceleration forces loaded (hide empty braking band)					
In TSB brakes (disc brakes)					
- set pressure at $p_m = 0,6$ bar					
- deceleration values - empty - into the mid to upper band limit band					
deceleration values between said first - and the last parameter point are linearly adjust .					
Recommendations for applications in Scandinavia :					
- deceleration values - empty and loaded - at the upper band limit 13					
Brake force distribution:					
Up to $p_m \geq 2.0$ bar, the ratio of $\frac{\text{brake force}}{\text{axle load rations}}$ of the individual axles of drawbar trailers must be kept as even as possible.					
Braking values at $p_m = 6.5$ bar: See page 1					
Service brake pressure :					
should not be more than 6,8 bar.					
Brake calculations with BPW brake cylinder:					
In case BPW brake cylinders are to be used in brake calculations, the value of $C_o = 17$ Nm has to be deducted for the calculated camshaft momentum owing to the omission of the outer return spring.					
Configuration of the parking brake system:					
The parking brake effect must be $z_{PE} \geq 0,23$ (23%).					
for Switzerland and England : $z_{PE} \geq 0,28$ (28%). 13					
Other BPW recommendations:					
Current information, including BPW- recommendation for tractor/trailer combinations can be found in the commercial vehicle catalogue and on the www.bpw.de website.					
In well-founded individual cases and after consultation of BPW Bergische Achsen KG a deviation from the before mentioned recommendations is possible.					
		Date : 28.04.2023	Date : 03.05.2023		
		Name : KÖCHL.U	Name : PEHLE.M		
Version	13	Changes : 101803			

3.1.1 Brake system design | Installation instructions for ECO Disc trailer disc brake

Maximum brake cylinder size of disc brake TS2

The brake cylinder size of 22" (service brake part) must not be exceeded for the ECO Disc TS2 3709 / 4309 disc brake.

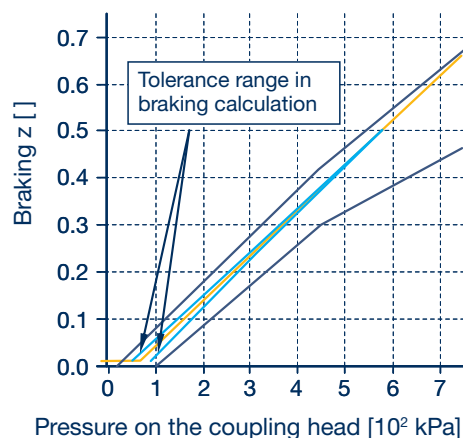
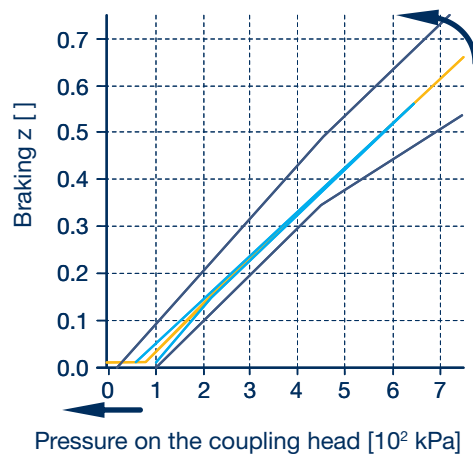

Recommendation for Scandinavian version

For vehicles with disc brakes that are intended for use in Scandinavia, the brake systems must be designed so that braking lies within the upper range of the tolerance bands. This should help to guard against underloading the brakes and avoid reducing the effectiveness of the brakes.



Braking should start at approx. 0.4 bars.

Compatibility bands in braking calculations in accordance with UN R13, Annex 11:

For braking problems in everyday use, the vehicles can also be subsequently adjusted without needing to adapt the approval, insofar as the braking calculations have a corresponding tolerance range. This must be checked by the vehicle manufacturer, which is generally the case for BPW braking calculations.

The vehicle documentation must correspond to the amended EBS parameters.

3.1.2 Brake data disc brakes

 Brake Data Disc brakes		TE - 2328.0E			
		3	Page P.-No. 1		
Disc brake TS2:					
Type of brake	Diameter of disc [mm]	Brake pad		permissible braking moment / brake ^{*)} (at 6,5 bar) [Nm]	
		Width [mm]	Thickness [mm]		effective braking area / brake [cm ²]
TS2 3709	Ø 374	210,8	21	2 x 143	14 100
TS2 4309	Ø 430	210,8	21	2 x 166	16 000
*) with $M_B = B_F \cdot (C - C_0)$					
Type of brake	TS2 3709	TS2 4309			
Calculated transmission	15,6	15,6			
Parameter $\eta_a C^*$	0,71	0,71			
Lever length l [mm]	70	80			
Eccentricity e [mm]	4,5	5,1			
Braking factor B_F	23,5	23,9			
average friction radius r [mm]	149	171,5			
contact moment C_0 [Nm]	10,5	12			
					
Date : 22.08.2019		Date : 22.08.2019			
Name : ABT.C		Name : PEHLE.M			
Version	10	Changes : 101096			

 Brake Data Disc brakes		TE - 2328.0E			
		3	Page P.-No. 2		
Disc brake TSB:					
Type of brake	Diameter of disc [mm]	Brake pad		permissible braking moment / brake (at 6,5 bar) [Nm]	
		Width [mm]	Thickness [mm]		effective braking area / brake [cm ²]
TSB 3709	Ø 374	210,8	23	2 x 147	17 000
TSB 4309	Ø 430	210,8	23	2 x 168	17 000
TSB 4312	Ø 430	246,9	21	2 x 192	18 500
Type of brake	TSB 3709	TSB 4309	TSB 4312		
Calculated transmission	15,5	15,5	15,5		
Parameter $\eta_a C^*$	0,71	0,72	0,72		
Lever length l [mm]	80	80	80		
Eccentricity e [mm]	5,16	5,16	5,16		
Braking factor B_F	20,5	23,9	23,9		
average friction radius r [mm]	149	171,5	171,5		
contact moment C_0 [Nm]	12	12	12		
Date : 22.08.2019		Date : 22.08.2019			
Name : ABT.C		Name : PEHLE.M			
Version	10	Changes : 101096			

 Brake Data Disc brakes		TE - 2328.0E			
		3	Page P.-No. 3		
Disc brake SB:					
Type of brake	Diameter of disc [mm]	Brake pad		permissible braking moment / brake (at 6,5 bar) [Nm]	
		Width [mm]	Thickness [mm]		effective braking area / brake [cm ²]
SB 3745	Ø 377	210,7	23 or 21	2 x 148	17 000
SB 4309	Ø 430	210,8	23	2 x 168	18 500
SB 4345	Ø 430	247,6	21	2 x 206	20 000
Type of brake	SB 3745	SB 4309	SB 4345		
Calculated transmission	15,51	15,51	15,3		
Parameter $\eta_a C^*$	0,71	0,72	0,71		
Lever length l [mm]	76	76	88		
Eccentricity e [mm]	4,9	4,9	5,75		
Braking factor B_F	21,59	25,2	21,17		
average friction radius r [mm]	149	171,5	171,5		
contact moment C_0 [Nm]	10	10	9		
Date : 22.08.2019		Date : 22.08.2019			
Name : ABT.C		Name : PEHLE.M			
Version	10	Changes : 101096			

3.1.3 Brake data drum brakes

		brake data				TE - 1498.0E	
		SN 300, SN 360 and SN 420				3 Page P.-No. 1	
type of brake	diameter of drum [mm]	brakelining			effective braking area/brake [cm ²]	perm. braking torque/brake (at 6,5 bar) [Nm]	
		width [mm]	thickness [mm]	length/brake shoe			
SN 3010	Ø 300	100	max. 18	287	550	7000	
SN 3012	Ø 300	120	max. 18	287	660	7700	
SN 3015	Ø 300	150	max. 18	287	819	8500	
SN 3020	Ø 300	200	max. 18	287	1118	14500	
SN 3616	Ø 360	160	max. 18	349	1070	13000	
SN 3620	Ø 360	200	max. 18	349	1348	17750	
SN 4212	Ø 420	120	max. 18	418	894	12500	
SN 4218	Ø 420	180	max. 18	418	1389	17000	
SN 4220	Ø 420	200	max. 18	418	1554	20750	
type of brake				SN 30..	SN 36..	SN 42..	
shoe factor C*				1,5	1,5	1,5	
mechanical efficiency η_a [%]				80	80	80	
shoe faktor η_a C*				1,2	1,2	1,2	
efficient radius of the cam shaft e [mm]				13	14	14	
radius of the brake drum r [mm]				150	180	210	
brake factor B _F				6,9	7,7	9	
righting torque C ₀ [Nm]				45*	50	50	
				* righting torque C ₀ amounts 30 Nm for the type of brake SN 3010			
Date : 23.05.2016		Date : 25.05.2016					
Name : KOECHL.U		Name : PEHLE.M					
Version	7	Changes : 101404					

		brake data				TE - 1498.0E	
		SN 3015 / BPW 6202				3 Page P.-No. 2	
type of brake	diameter of drum [mm]	brake lining			effective braking area/brake [cm ²]	perm. braking torque / brake (at 6,5 bar) [Nm]	
		width [mm]	thickness [mm]	length / brake shoe [mm]			
SN 3015	Ø 300	150	max. 18	287	819	8500	
type of brake				SN 3015			
shoe factor C*				1,87	④		
mechanical efficiency η_a [%]				80			
shoe faktor η_a C*				1,5			
efficient radius of the cam shaft e [mm]				13			
radius of the brake drum r [mm]				150			
brake factor B _F				8,65			
righting torque C ₀ [Nm]				45			
Date : 23.05.2016		Date : 25.05.2016					
Name : KOECHL.U		Name : PEHLE.M					
Version	4	Changes : 100404					

		Brake data				TE - 1498.0E	
		SN 5020				3 Page P.-No. 3	
type of brake	diameter of drum [mm]	Brake lining			effective braking area/brake [cm ²]	perm. braking torque/brake	
		width [mm]	thickness [mm]	length/brake shoe			
SN 5020	Ø 500	200	max. 18	441	1735	29000	
type of brake				SN 5020			
shoe factor C*				1,5			
mechanical efficiency η_a [%]				80			
shoe faktor η_a C*				1,2			
efficient radius of the cam shaft e [mm]				14			
radius of the brake drum r [mm]				250			
brake factor B _F				10,7			
righting torque C ₀ [Nm]				50			
Only characteristic value test , no ECE R13 report available ! ①							
Date : 23.05.2016		Date : 25.05.2016					
Name : KOECHL.U		Name : PEHLE.M					
Version	1	Changes : 100404					

3.1.4 Test reports, expert opinions | Test reports for BPW drum brakes according to ECE R13



[Service / Downloads](#)

Brake type ID2	Brake disc Ø x thickness	Axle type ID1	Brake lining	Test axle load		Dynamic tyre radius		Tyres tested	Slack adjuster	Test report number ID4
				ID3 (daN)	(kg)	R tested (mm)	R x 0.8 min. permissible (mm)			
SN 3010	Ø 300 x 100	N 50	T 090	5000	5097	256	204.8	6 R9	AGS-2	19160127
SN 3010	Ø 300 x 100	N 62	T 090	6082	6200	372	297.6	215/75 R17.5	AGS-0, AGS-2	19160124
SN 3012	Ø 300 x 120	N 72	BPW 6200, BPW 6203	7063	7200	383	306.4	245/70 R17.5	AGS-0, AGS-2	36107411
SN 3015	Ø 300 x 150	N 75	T 090	7358	7500	372	297.6	215/75 R17.5	AGS-0, AGS-2	36109413
SN 3015	Ø 300 x 150	N 97	BPW 6202	9516	9700	382	305.6	235/75 R17.5	AGS-0	36113905
SN 3020	Ø 300 x 200	N 102	T 090	10002	10200	382	305.6	235/75 R17.5	AGS-0, AGS-2	36102104
SN 3020	Ø 300 x 200	N 130	T 090, BPW 6203	12753	13000	383	306.4	245/70 R17.5	AGS-0, AGS-2	36108112
SN 3620	Ø 360 x 200	K 135	T 090	13244	13500	432	345.6	285/70 R19.5	AGS-0, AGS-2	36106802
SN 4212	Ø 420 x 120	H 85	T 090	8339	8500	494	395.2	10 R22.5	AGS-0, AGS-2	19160125
SN 4218	Ø 420 x 180	H 102	T 090, BPW 6404	10006	10200	522	417.6	315/80 R22.5	AGS-0, AGS-2	36108212
SN 4220	Ø 420 x 200	H 122	T 090, BPW 6404	11968	12200	522	417.6	315/80 R22.5	AGS-0, AGS-2	19160120
SN 4220	Ø 420 x 200	H 142	T 090	13930	14200	543	434.4	13 R22.5	AGS-0, AGS-2	19160126

The identification of the axle type ID 1 consists of a letter for the BPW axle series and the tested axle load in 100 kg.

The maximum possible tire radius depends on the brake calculation.

The minimum deceleration required by law must be ensured.

3.1.4 Test reports, expert opinions | Test reports for BPW disc brakes according to ECE R13



[Service / Downloads](#)

Brake type ID2	Brake disc Ø x thickness	Axle type ID1	Brake lining	Test axle load		Dynamic tyre radius		Tyres tested	Test report number ID4
				ID3 (daN)	(kg)	R tested (mm)	R x 0.8 min. permissible (mm)		
TS2 3709	Ø 374 x 45	D 114	BPW 8201, BPW 8303, BPW 8102	11180	11400	434	347.2	19.5"	36102117
TS2 4309	Ø 430 x 45	D 116	BPW 8201, BPW 8303, BPW 8102	11380	11600	451	360.8	22.5"	36103516
TSB 4312	Ø 430 x 45	D 142	BPW 8301, BPW 8101	13930	14200	541	432.8	22.5"	36107309
SB 3307	Ø 330 x 34	D 70	Wabco 210	6867	7000	372	297.6	17.5"	36112311

The identification of the axle type ID 1 consists of a letter for the BPW axle series and the tested axle load in 100 kg.

The maximum possible tyre radius depends on the brake calculation.

The minimum deceleration required by law must be ensured.

Sample certificates are also available for the disc brakes, which simplify the homologation of a vehicle type, see also -> BPW News 73881713d Sample certificate disc brake TS2

Equivalence certificates confirm the comparability of the TSB and TS2 disc brake generations and various brake pads with regard to the test conditions of ECE R13.11 in their characteristic properties.

3.1.5 Brake calculation data sheet

BPW offers its customers the creation of vehicle-specific brake calculations. This form must be used for this purpose:

[Vehicle data sheet](#)

As a result, the appropriate brake cylinder size is determined for disc brakes. For drum brakes, the lever length for connection to the slack adjuster is also specified.

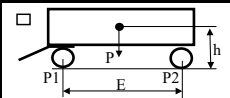
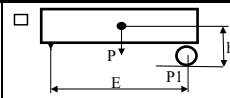
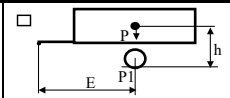
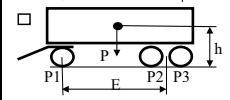
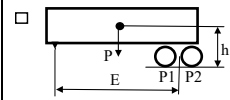
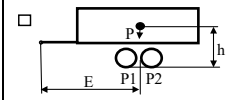
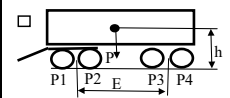
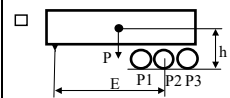
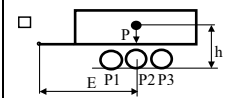
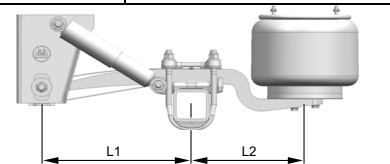
		BPW Bergische Achsen Kommanditgesellschaft • Postfach 12 80 • D-51656 Wiehl			
		attention of: Herrn Köchl		attention of: Herrn Abt	
		E-Mail: KoeschlU@bpw.de		E-Mail: AbtC@bpw.de	
		facsimile: +49 (0) 2262 / 78 - 4137		facsimile: +49 (0) 2262 / 78 - 4751	
		telephone: +49 (0) 2262 / 78 - 1137		telephone: +49 (0) 2262 / 78 - 1751	
from:					
company:					
street / P. O. B.:					
postcode, city:					
E-Mail:					
telephone:					
facsimile:					
customer no.					
<input type="checkbox"/> 		<input type="checkbox"/> 		<input type="checkbox"/> 	
<input type="checkbox"/> 		<input type="checkbox"/> 		<input type="checkbox"/> 	
<input type="checkbox"/> 		<input type="checkbox"/> 		<input type="checkbox"/> 	
trailer manufacturer		gross weight P [kg]	laden	unladen	if already existing size of brake cylinder
type of vehicle		axle load P1 [kg]			lever length
brake equipment manufacturer		axle load P2 [kg]			
ABS?	<input type="checkbox"/> Yes <input type="checkbox"/> No	axle load P3 [kg]			
EBS?	<input type="checkbox"/> Yes <input type="checkbox"/> No	axle load P4 [kg]			
brake size		centre of gra- vity h [mm]			
report (TDB) no.		wheel base E [mm]			
type of axle / code-no.		tyre size 1		eventually tyre size 2	
type of suspension / code no.		type of suspension <input type="checkbox"/> air <input type="checkbox"/> VA <input type="checkbox"/> VB <input type="checkbox"/> W <input type="checkbox"/> single axle <input type="checkbox"/> hydraulic			
			remarks (e. g.: steering axles, lift axles; etc.)		
L1	L2	air bag	<input type="checkbox"/> 30	<input type="checkbox"/> 36	
Note: Please indicate your customer number.					

3.2 Brake cylinder

3.2.1 Functions and features | Variants

- Perfect sealing and compactness due to flanging (no screw clamps)
- Optimum corrosion protection (housing and springs)
- Easy to install thanks to optional compressed air connection extensions (standard for spring-loaded cylinders for disc brakes)

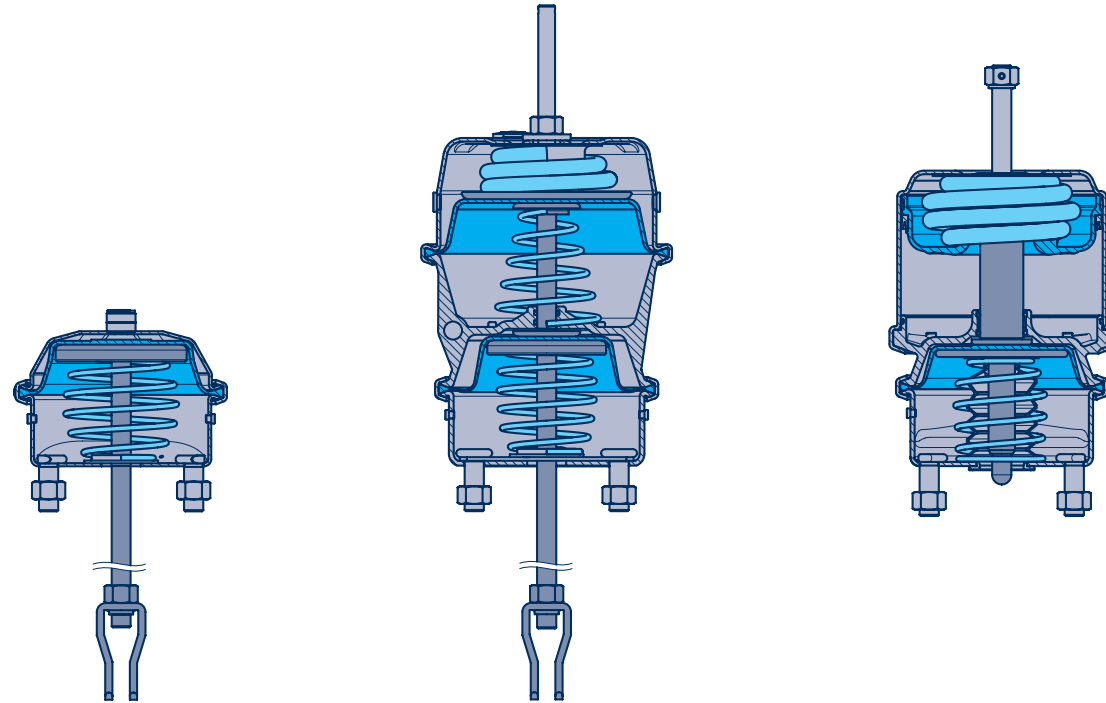
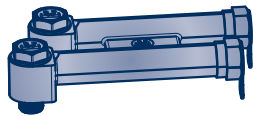

- When combining BPW brake cylinders with BPW drum brakes, no additional external return spring is required between the slack adjuster and the base plate.
- As original equipment, BPW axles can be supplied with fully assembled brake cylinders. Adjustment work for drum brakes is then not necessary.

Diaphragm cylinder	Diaphragm-diaphragm cylinder (M-M)	Diaphragm piston cylinder (M-K)
<p>These act as a service brake and are characterised by their compact external dimensions and low weight.</p> <p>(Illustration for drum brakes)</p>	<p>They act both as a service brake as well as an auxiliary and parking brake. They are lighter than the diaphragm-piston cylinder.</p> <p>(Illustration for drum brakes)</p>	<p>They have the same function as a diaphragm-diaphragm cylinder. Their greater spring-type accumulator force means they are suited above all for vehicles with higher axle loads and limited installation space.</p> <p>(Illustration for disc brakes)</p>

3.2.1 Functions and features | Function description

Functional description using an example of the spring-loaded cylinder (here diaphragm-diaphragm cylinder)



Driving

Spring accumulator part (top) is vented, the large spring is retained. The service brake part (bottom) is depressurized.

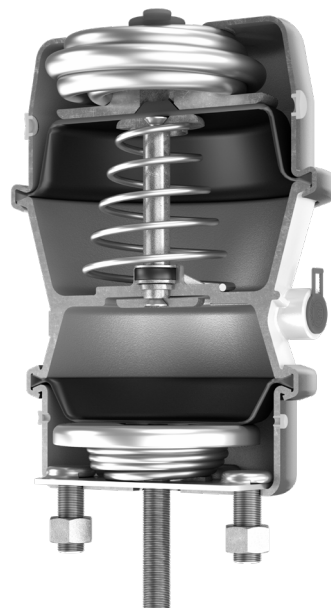

Service brake

Air pressure in the brake mechanism actuates the brake via the push rod. The spring accumulator section remains ventilated.

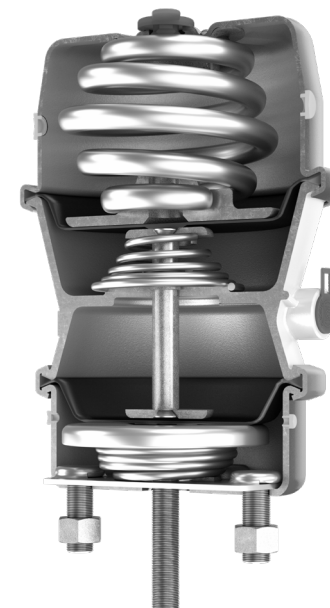

Handbrake or parking brake

When activated, both the service brake section and the spring brake section are initially pressurised with the maximum supply pressure so that the service brake cylinder brakes the trailer. If the trailer is stationary for a longer period of time and the associated pressure loss occurs, the wheel brake is automatically and safely applied by the large spring via the pressure rod.

3.2.1 Functions and features | Release device

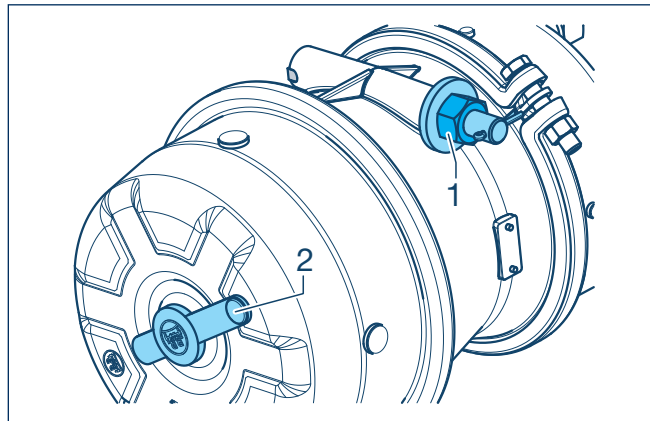
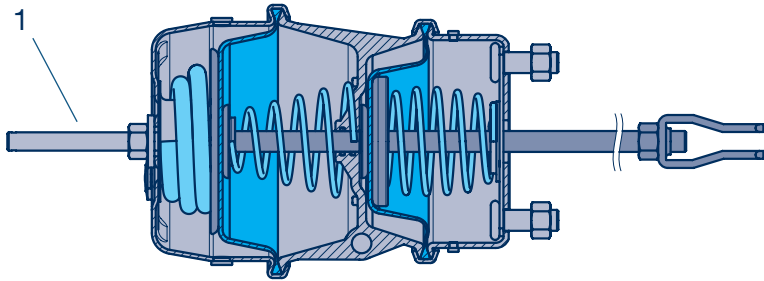

Each spring brake cylinder also contains a release device (1) for pre-tensioning the parking brake spring. In the delivery condition of the loose brake cylinders, the release device is clamped and thus the parking brake is released so that the cylinder can be mounted immediately. After cylinder assembly and adjustment of the slack adjuster, the release device is removed and can be parked in the lateral holding device on the cylinder.

In the vehicle, the release device is used, for example, during towing in the event of a depressurized pneumatic system.

Release device inserted. Spring accumulator released.

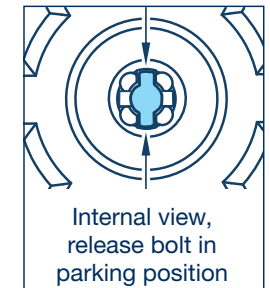
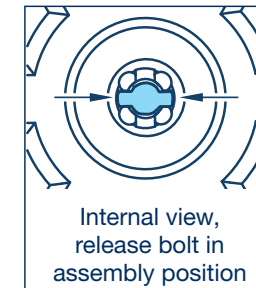
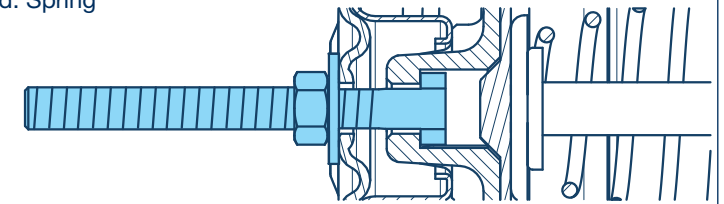

Release device in parking position, Plastic sleeve and cap mounted.

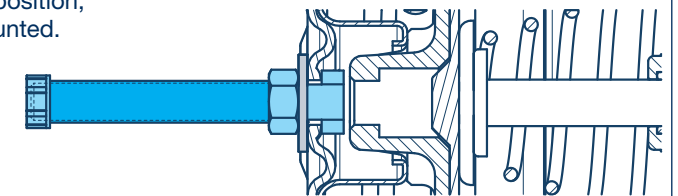

On BPW brake cylinders for disc brakes, as an alternative to the lateral holding device, it is possible to deactivate the release device by twisting. To do this, tighten the nut and fit the plastic sleeve and protective cap. The release device thus remains inserted in the longitudinal direction of the cylinder.

3.2.2 Versions

Brake cylinder for disc brakes

Diaphragm cylinder		Diaphragm-diaphragm cylinder		Diaphragm-piston cylinder	
Cylinder size	Piston stroke S_{max} (mm)	Cylinder size	Piston stroke S_{max} (mm)	Cylinder size	Piston stroke S_{max} (mm)
14"	62	14/24"	61		
15"	60	15/24"	57		
16"	60	16/24"	56	16/16"	60
18"	65	18/24"	63		
20"	65	20/24"	64	20/24"	68
22"	69			22/24"	65
24"	66			24/24"	65

The designation of the brake cylinders (e.g. 20/24") is derived from the effective area of the diaphragm or piston (actually inch²).

BPW brake cylinders for drum brakes are long-stroke cylinders as standard and have a push rod length of 185 mm (unactuated, measured without clevis). Shorter pressure bars are also available in some cases.

BPW brake cylinders for disc brakes are available in both left-hand and right-hand versions. Spring-loaded brake cylinders for disc brakes are supplied with mounted compressed air connection extensions as standard.

Due to their weight, diaphragm piston cylinders are not suitable for self-steering (LL) axles.

The installation of cylinders other than BPW cylinders is the responsibility of the vehicle manufacturer. This also applies to the interfaces, such as brake cylinder sealing for disc brakes or base plate mounting as well as clearance inspections for drum brakes.

Technical data and installation dimensions see document [BPW brake cylinders for axles with disc and drum brakes](#)

Brake cylinder for drum brakes

Diaphragm cylinder		Diaphragm-diaphragm cylinder	
Cylinder size	Piston stroke S_{max} (mm)	Cylinder size	Piston stroke S_{max} (mm)
12"	78		
16"	80	16/24"	74
20"	75	20/30"	75
24"	75	24/30"	75
30"	79	30/30"	80
36"	75		

CCF diaphragm diaphragm cylinder for drum brakes

For drum brakes, the standard sizes of the diaphragm diaphragm cylinders are also optionally available in the „Coil Clash Free“ (CCF) version. They are characterised by an 11 - 36 mm longer housing of the spring brake section, as the coils of the parking brake spring do not touch each other when they are pushed together. This can significantly increase the service life of the spring.

Depending on the installation space situation, the MM standard cylinder can be replaced by the MM-CCF cylinder. The force output is within the tolerance band of the MM standard cylinder and has been confirmed by a TÜV certificate (no homologation required).

[Available CCF drum brake cylinders](#)

3.2.3 Test reports

	Disc brake	Drum brake
Diaphragm cylinder	BC 0055.2 Test Report No. BC 0055.2 for application of Annex 19, ECE Regulation No. 13 (bpw.de)	BC 0069.2 309370_0179__1.pdf (bpw.de)
Diaphragm-diaphragm cylinder	BC 0056.2 Test Report No. BC 0056.2 for application of Annex 19, ECE Regulation No. 13 (bpw.de)	BC 0070.2 309371_0180_.pdf (bpw.de) BC 0070.2 Konformitätsprüfung CCF Bremszylinder BPW-2024-TUEV_Pruefbericht_MM_CCF_TB_Bremszylinder-BC0070_2_Erweiterung_CCF.pdf
Diaphragm-piston cylinder	BC 0077.3 BPW_23\es-c00000028.pdf	-

3.3 ABS sensor, exciter ring

3.3.1 Versions

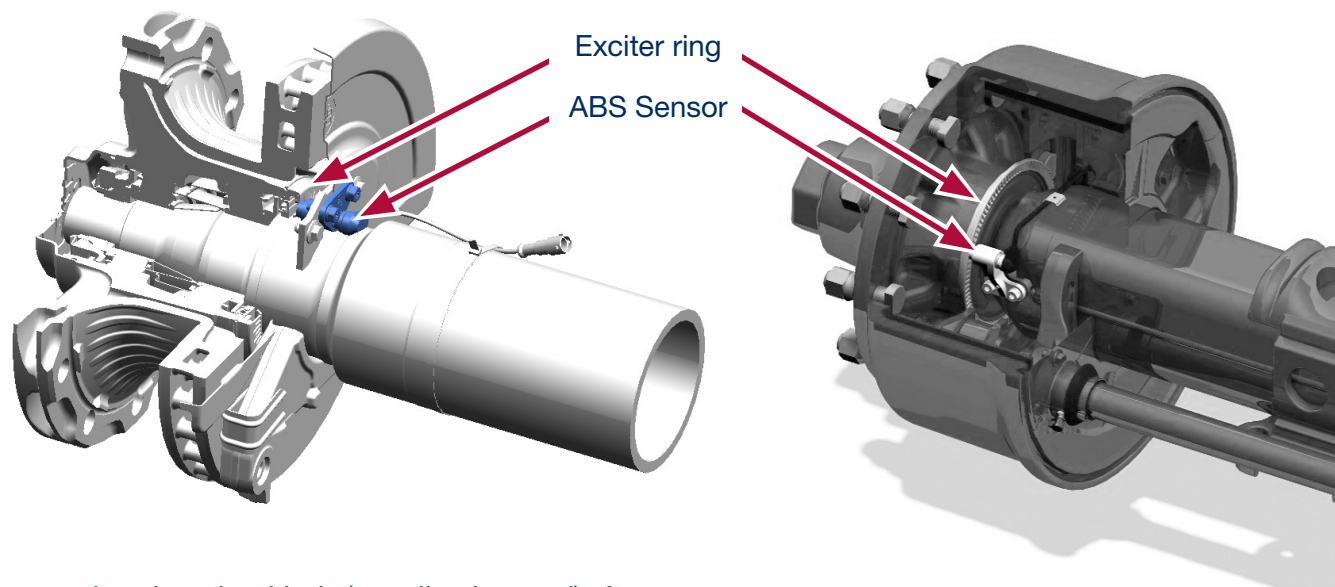

The exciter ring is connected to the wheel hub (usually clamped). An inductive ABS sensor mounted on the axle beam measures the wheel speed for the electronic braking system (EBS). This enables functions such as automatic anti-lock braking (ABV or ABS), the electronic stability program (ESP) or roll-over prevention (RSP). The spacing of the exciter ring teeth is based on the rolling circumference of the wheels.

BPW installs the following exciter rings on the ECO Plus 3 axle generation:

9 t axle load: => spacing with 90 teeth for tyre rolling circumference 2466 mm to 3312 mm

10...12 t axle load: Wheel connection \varnothing 335 x 10 => spacing with 100 teeth

Wheel connections \varnothing 275 x 8 and \varnothing 225 x 10 => spacing with 80 teeth

The sensor or exciter ring can be retrofitted to almost all BPW axles.



Example Sensor



*Example exciter ring
for 10 - 12 t*

3.3.2 Retrofit ABS sensor

Sensor retrofitting is possible without removing the wheel end on the TS2 3709 and TS2 4309 (for 9 tonnes with offset 120) thanks to pre-mounted exciter ring (standard on ECO Plus 3).

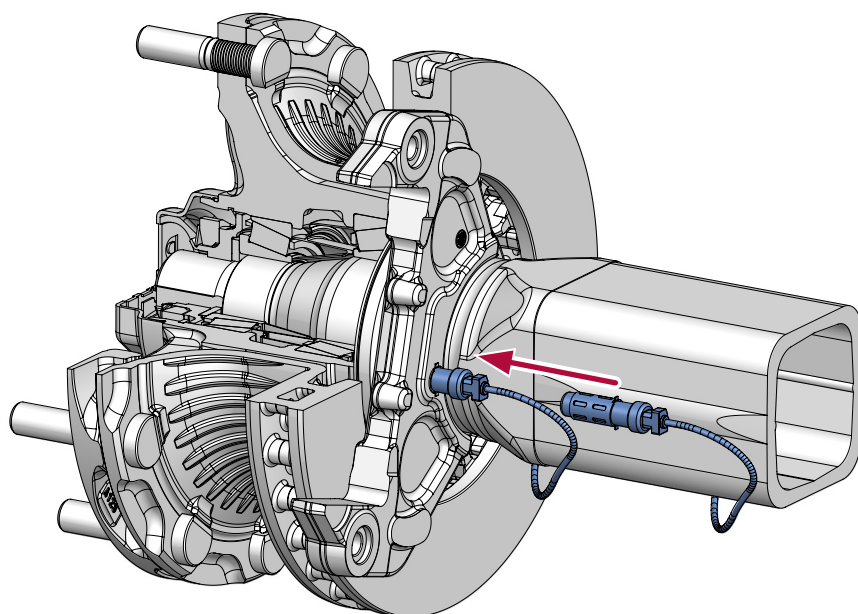

With square axle beams (SHB, SKHB series), the sensor is pushed into the brake calliper bracket and pressed against the exciter ring.

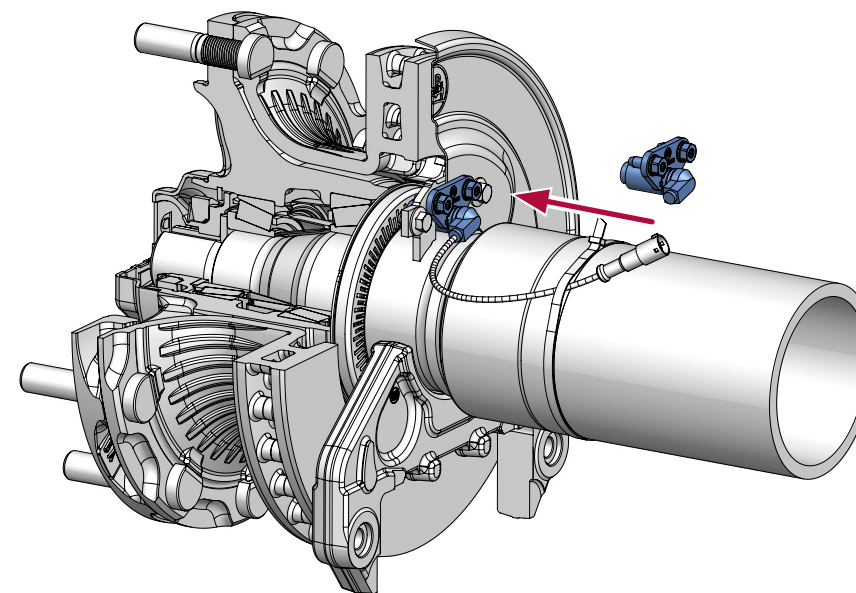

For round axle beams (SRB, SKRB series), the sensor is threaded in together with its holder, screwed on (2 x M 8x20) and pressed onto the exciter ring.

[Workshop manual TS2](#)

3.3.3 EBS installation and number of axles to be sensed

- For heavy trailers and center axle trailers (O3, O4), at least one axle must be provided with two wheel sensors (2S). In this case, at least two modulators are needed in the EBS system for braking force control (right and left) (2M), the system is then designated 2S2M.
- For heavy turntable trailers (O3, O4), the steered front axle must also be sensed. Steering axles are ideally controlled by a separate modulator to avoid steering movements during braking in the event of different friction values on the right / left, so that a 4S3M system is required in total.
- For the same reason, it is also advisable to equip steering axles in trailers with their own sensors and modulator (4S3M). Although it is also possible to install a so-called Select-Low system (as 2S2M), in which the lowest friction value (right or left) determines the uniform braking force of all axles in order to suppress steering during braking. However, this solution is not recommended from a safety point of view, as the full braking force potential is then not utilized.
- Detailed application recommendations for the brake system are available from the brake system manufacturer.

3.4 Base plates for drum brake axles

3.4.1 General

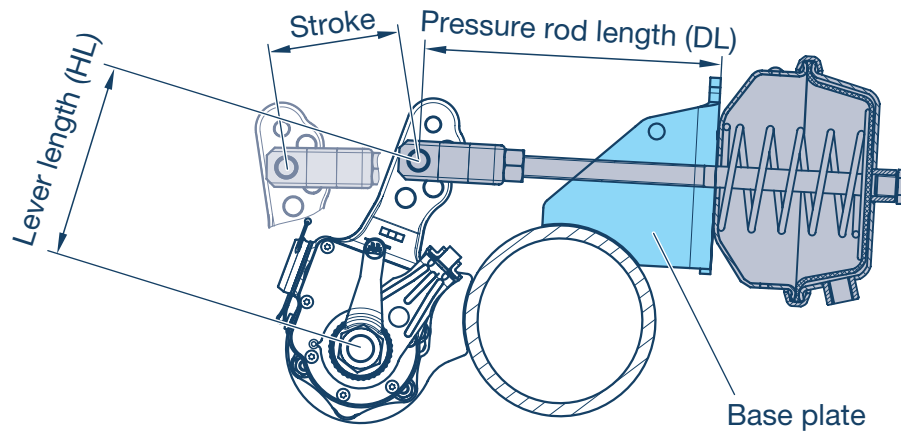

The brake cylinder mounted on the base plate transmits its force to the slack adjuster via the cylinder pressure rod by means of the fork head. The brake camshaft thus undergoes a rotary motion and spreads the brake shoes, which then rub against the brake drum.

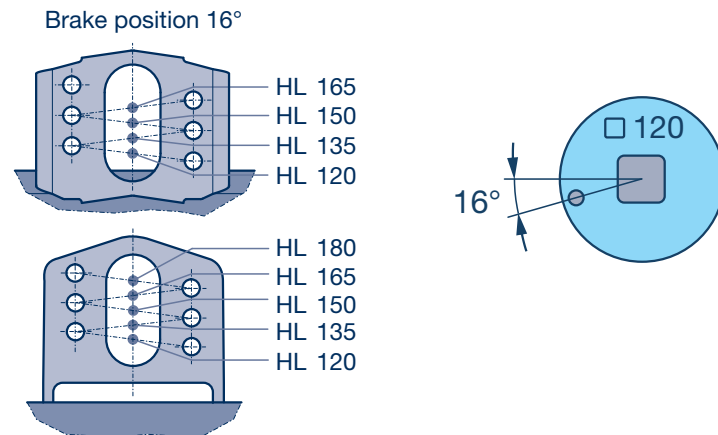

The vehicle-specific brake calculation defines the torque on the brake camshaft via the brake cylinder size and the lever length (HL). BPW offers a variable hole pattern for both the base plates and the slack adjuster to allow different lever lengths to be installed. The picture example refers to the brake position 16° for the square 120 axle beam.

The shape and position of the base plate on the axis precisely matches the position of the slack adjuster to ensure optimum power transmission and limit the swivel movement of the cylinder push rod (usually +/- 3°). BPW offers a wide range of different base plate designs below in order to make the best possible use of the installation space on each axle and vehicle type.

BPW axles with their base plates are designed for BPW brake cylinders. If brake cylinders from other manufacturers are installed, BPW should be consulted.

3.4.2 Versions | Axle type (brake): NH (SN 3020) and KH (SN 3620)

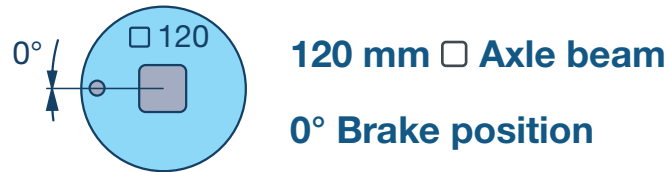

Base plate type	N	H	U	K	F	R
DIRECTION OF TRAVEL ← →						
	Standard					Standard
DL (mm)	227	155	170 (NH) 180 (KH)	155	82	227

3.4.2 Versions | Axle type (brake): H (SN 4218 and SN 4220)

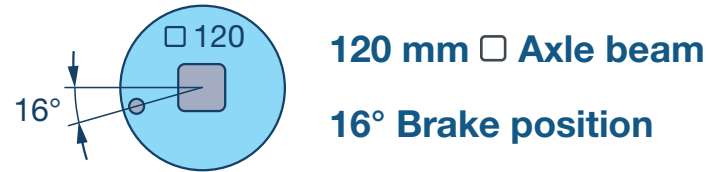

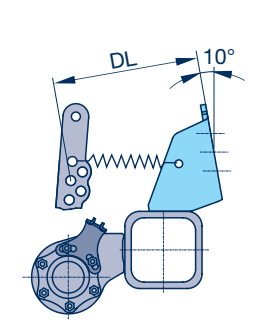
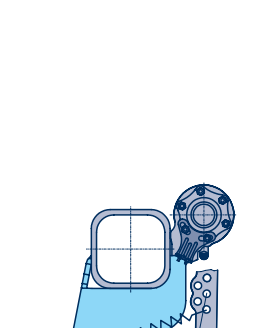
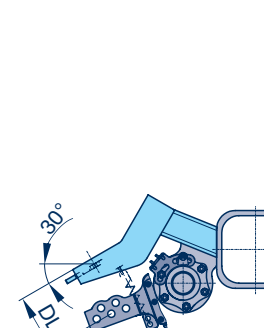
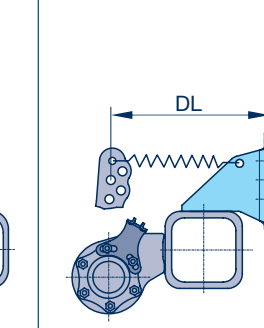
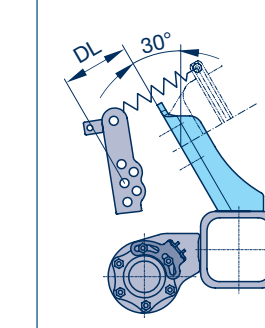
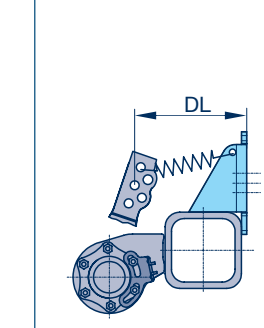
Base plate type	N	U	S	R	F	P
DIRECTION OF TRAVEL ← →						
	AL II only	AL II only		Standard	AL II only	AL II only
DL (mm)	227	190	80	227	113	180

3.4.2 Versions | Axle type (brake): H (SN 4220)

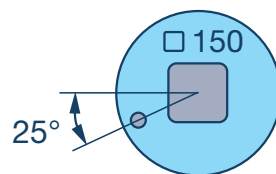

150 mm □ Axle beam

25° Brake position

Base plate type	N	F	S	U	U
<p>DIRECTION OF TRAVEL</p>					
	Standard	Standard			
DL (mm)	227	110	80	227	227

3.4.2 Versions | Axle type (brake): R (SN 4218)

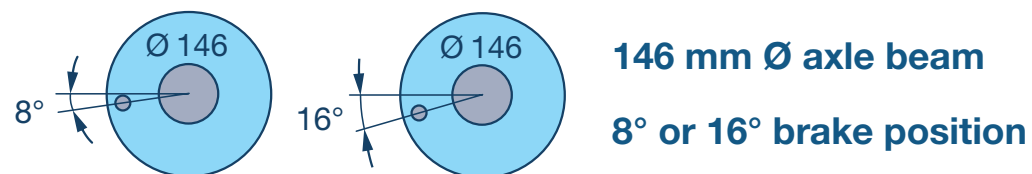

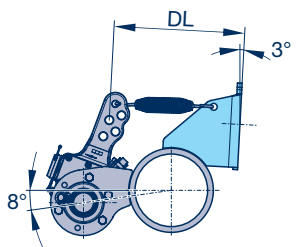
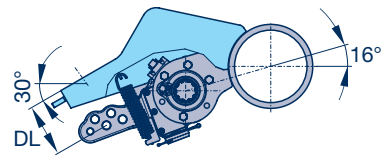
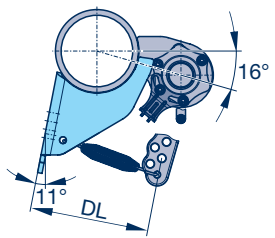
Base plate type	R	S	U
DIRECTION OF TRAVEL ← →			
	Standard		
DL (mm)	227	80	210

3.5 Slack adjuster ECO-Master

Versions

The automatic slack adjuster ECO-Master is designed to give the optimum clearance in BPW S-cam brakes.

3 versions are used:

AGS-0: Adjustment angle approx. 16°

AGS-2: Adjustment angle approx. 17.5°

AGS-5: Adjustment angle approx. 19.5°

Levers with different shapes and crank values are available depending on the particular installation conditions. With straight levers, the slack adjuster can be mounted on the left or right side; separate left- or right-hand versions are therefore not required.

The BPW ECO-Master meets the ECE R13 directive and in conjunction with BPW axles tested by the TÜV.

Delivery variants

- Packed together with BPW axles
- Pre-installed on BPW axles together with BPW brake cylinders
- For converting existing BPW axles from manual to automatic slack adjusters.

[Slack adjuster ECO-Master on youtube](#)

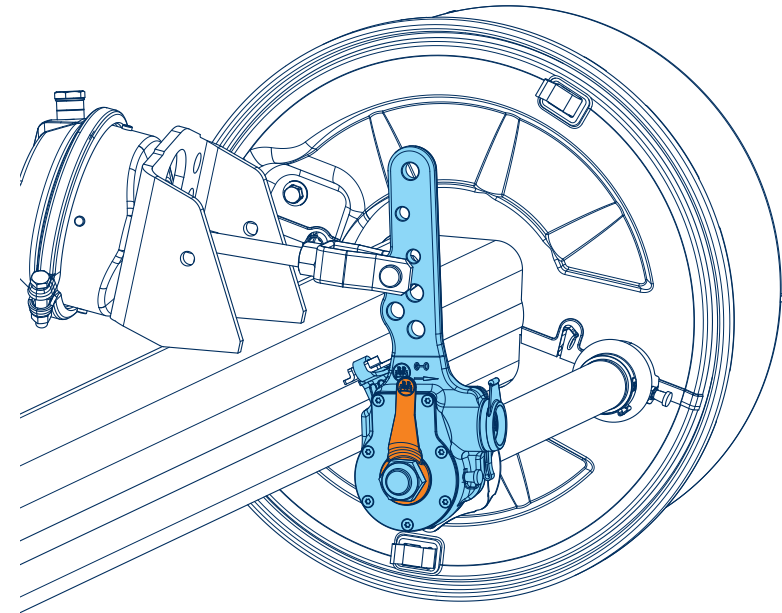

Special features

Forged brake levers guarantee optimum strength and permit the lever end to be modified

- Closely graded for ECE brake calculations thanks to multiple-hole levers
- All adjustment parts are protected inside the adjuster
- Areas prone to wear are surface-hardened
- Adjustment coupling with special tooth profile
- Control lever and fixed point holder are in the protected space
- Positively engaged, zero-play, low-wear push-in connection with pads between the control lever and fixed point holder
- Brake lining wear indicator

Sequence of the braking process

- H = Free stroke of the brake cylinder to cover the clearance (SB) between the brake lining and the brake drum
- E = Elasticity of the wheel brake and its transmission elements.
- V = Increase in stroke due to wear and heating
- SB = Clearance

The principle of automatic adjustment

Brake linings and brake drums are wear parts. As the thickness of the material is reduced, the brake cylinder stroke increases by the value (V), meaning that the brake camshaft has to rotate further.

At a maximum rotation of 19.5° , depending on the version, the automatic adjustment mechanism of the ECO-Master automatic slack adjuster makes the appropriate adjustment.

As a result, the brake cylinder stroke is always kept within the same, optimal zone of action. The adjustment stroke is designed so there will always be a sufficient clearance even at higher levels of elasticity and thermal expansion.

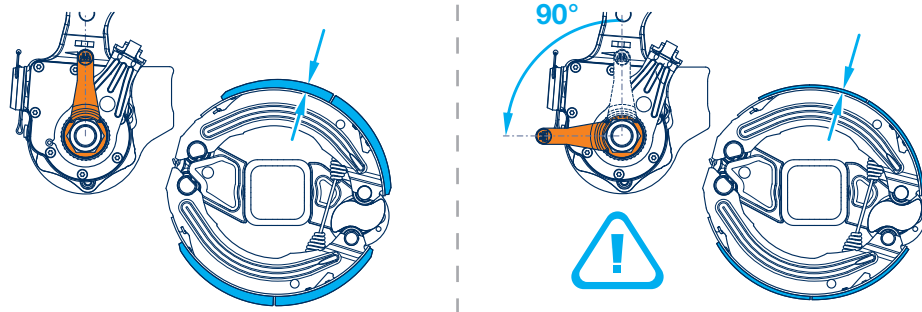
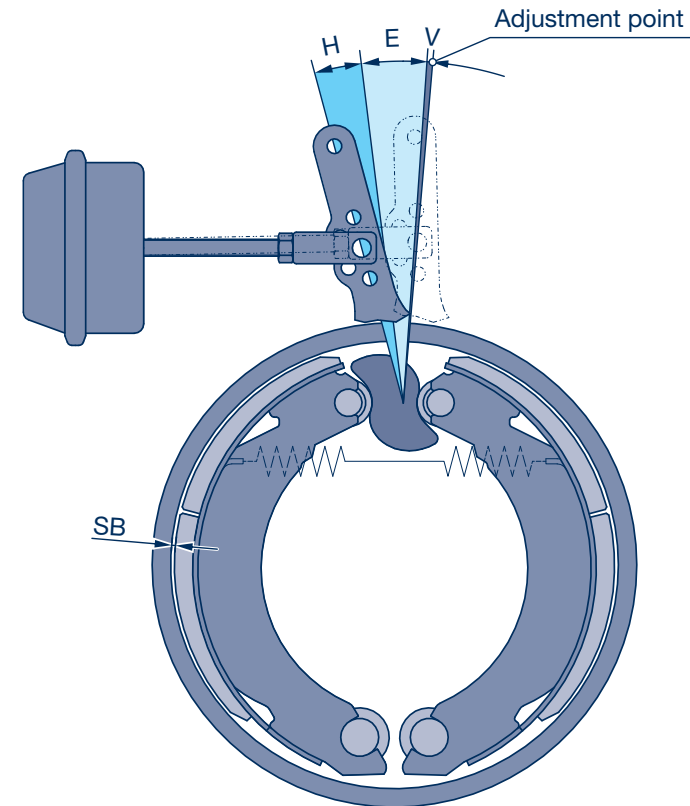

Function wear indicator

Orange indicator lever is vertical => new brake pads

Orange indicator lever is horizontal => worn brake pads

3.6 Drum brake ECO Drum

3.6.1 Transport and storage

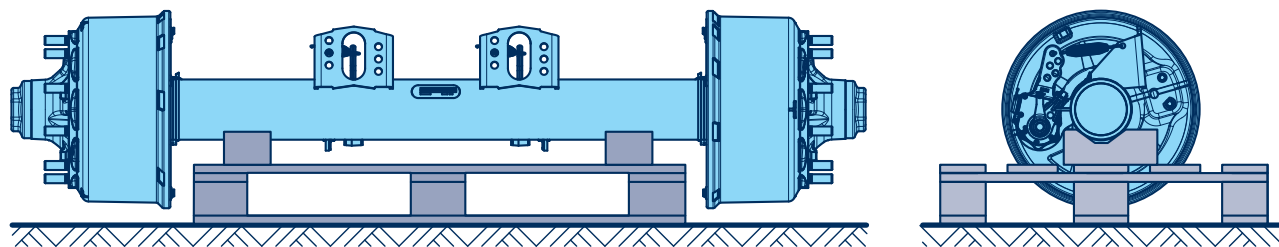

When transporting and storing the axles, a suitable rack or support should be used to avoid impacts, e.g. on the brake drum rim.

Otherwise cracks may occur (brake drums must then be replaced immediately). The brake drum rim should be relieved until the wheels are mounted. Wheels that are only required in-house during vehicle production should be mounted with at least 4 wheel nuts each and the intended torque.

3.6.2 Installation and adjustment *

! The tightening torques, safety instructions, care and maintenance specifications as well as information on component changing can be found in the appropriate workshop manual at www.bpw.de.
! [Workshop manual](#)

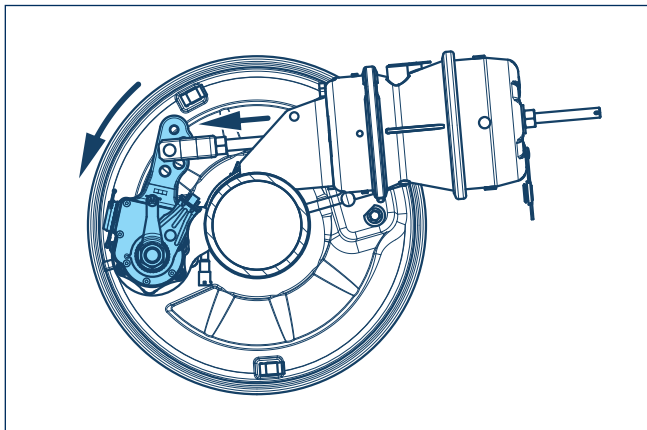

1. When braking, it is important to ensure that the rotational direction of the brake camshaft and the operating direction of the slack adjuster correspond to the rotational direction of the wheel. Otherwise, low-frequency noise may result.

Any other installations must be approved by BPW.

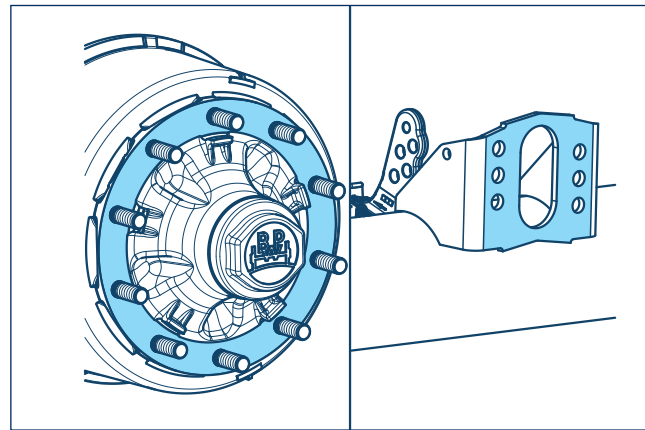

2. The following areas of drum brakes must be covered or masked off prior to any potential painting:
 - Contact surface of the brake cylinder and fastening nuts in the case of non-assembled brake cylinders.
 - Wheel contact surfaces

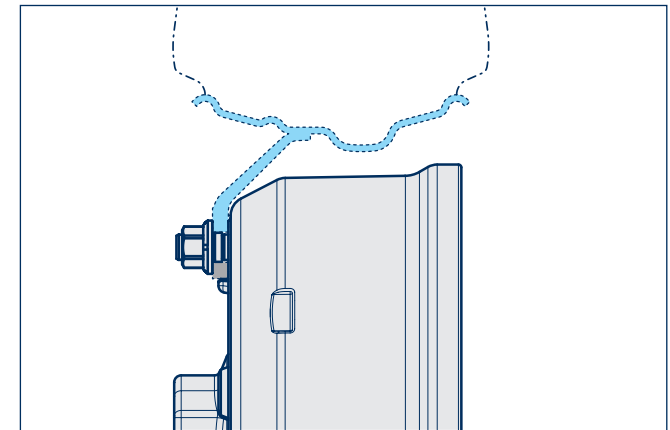

3. Use only rims which ensure sufficient clearance to the brake drum and all installed brake components.

The minimum spacings between the brake drum and rim as given in the TÜV surveys must be maintained, if necessary, borderline cases must be agreed with the appropriate registration office.

* The typical work steps at the vehicle manufacturer are described here if the brake cylinders are not pre-assembled ex works BPW. For replacement of the slack adjuster: see workshop manual Drum brake axles

3.6.2 Installation and adjustment

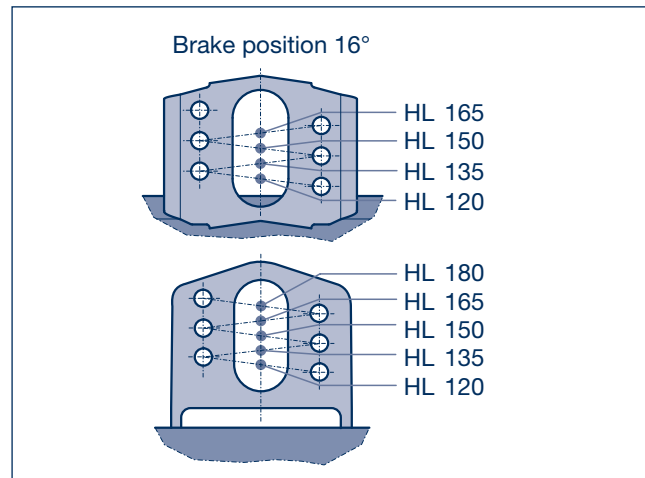

4. Mounting BPW brake cylinder on base plate

Position according to vehicle-specific brake calculation.

The example shows two typical base plates for brake position 16° (see technical data of the axle). Tightening torque of the fastening nuts $M = 180 - 210 \text{ Nm}$

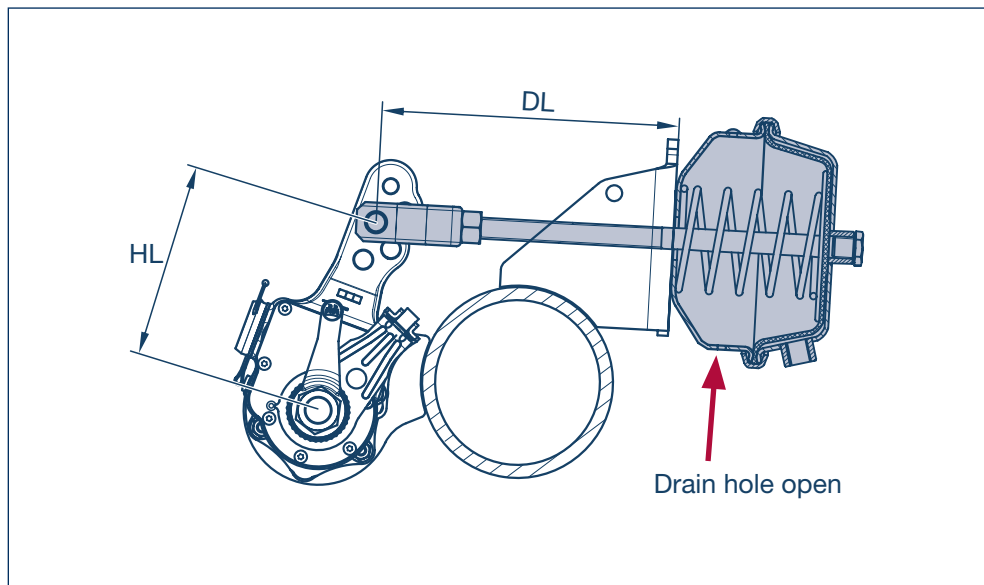

5. Set the length of the pressure rod according to the technical data of the axle.

Example shows standard dimension 227 mm.

Tightening torque of the lock nut on the clevis $M = 80 \text{ Nm}$.

6. The clevis of the push rod must be mounted on the hole in the slack adjuster lever that matches the intended lever length (HL).

This hole results when the pressure rod is at right angles to the base plate and at the same time at right angles to the slack adjuster lever.

7. Remove plugs on brake cylinder that are farthest down so that drainage holes are open.

3.6.2 Installation and adjustment

[Slack adjuster
ECO-Master
on youtube](#)

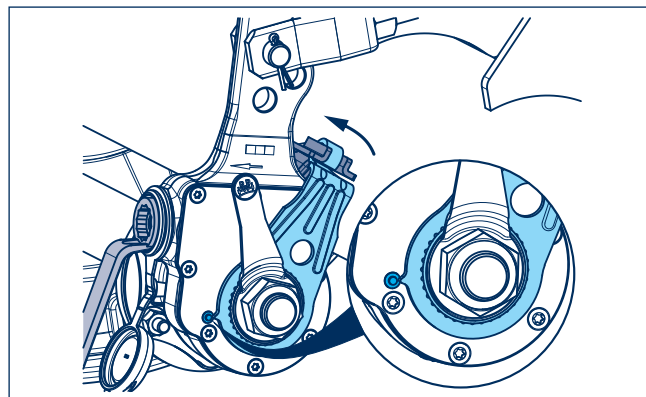
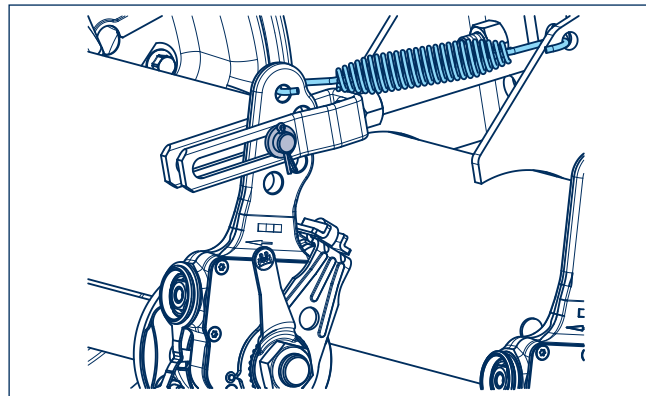
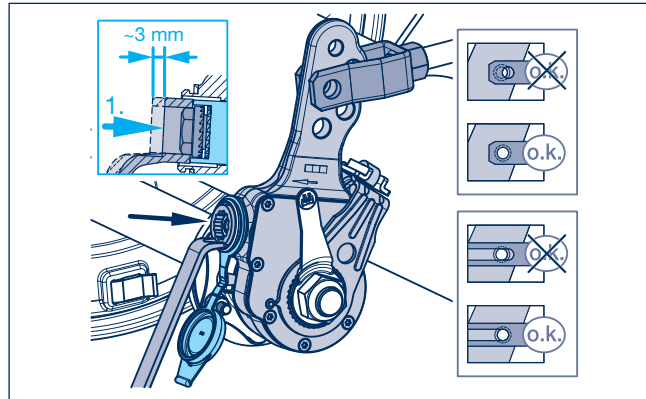

8. Remove rubber cap, press down coupling sleeve with ring wrench (width across flats 19) by approx. 3 mm (arrow) and align bolt hole in brake lever exactly with round hole or end of slotted hole in fork head by turning to the left or right. Insert and secure the bolt.

9. The outer return spring is no longer required on BPW brake cylinders with round-hole fork heads.

For other brake cylinder makes as well as for slotted fork heads, the tension spring must be hooked in at a lever length of 150 to 180 mm.

10. If the lug on the control lever still does not point to the control point, hold the coupling sleeve down and turn the control lever and shaped plate in the direction of the arrow until they reach the bumper. The lug on the control lever then points to the control point on the ECO Master (basic setting).

3.6.2 Installation and adjustment

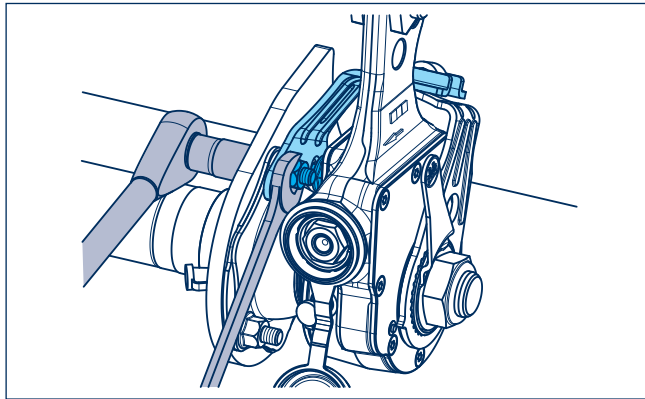

11. Secure plate with two hexagon bolts and lock nuts to inner side of supporting bearing (Tightening torque $M = 28 \text{ Nm}$).

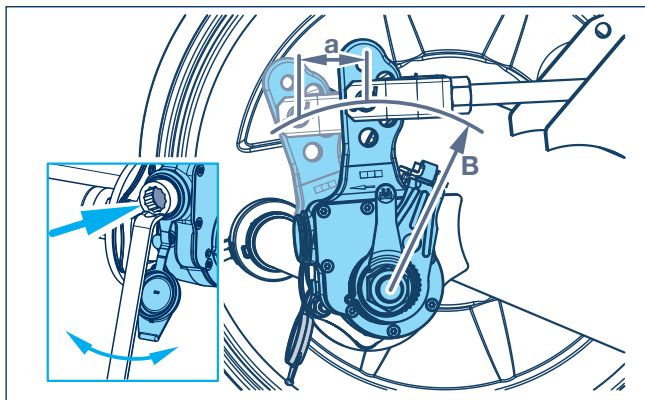

12. Set the idle stroke "a" to 10 - 15 % of the connected brake lever length "B" by turning the adjusting hexagon (again, press down the coupling sleeve with a ring wrench). Example: brake lever length 150 mm \Rightarrow empty stroke 15 - 22 mm.

The brake cylinder pressure rod and the lever of the slack adjuster must form an angle of approx. 90° when the brake is applied. Check by manual actuating, or with air pressure in the brake cylinder of 0.8 bar. Then press the rubber cap back on.

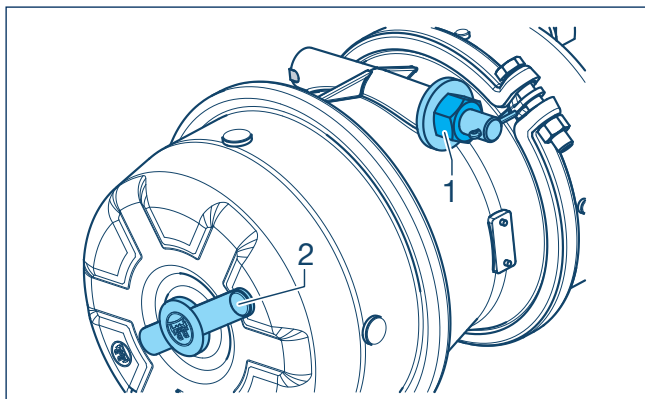

13. The mechanical release device on the spring brake cylinder must be dismantled after assembly or adjustment and inserted in the holding device (parking position) provided for this purpose.

The nut (1) must be secured with $M = 20 \text{ Nm}$ and the plug (2) reinserted in the brake cylinder.

3.7 Disc brake ECO Disc

3.7.1 Transport and storage

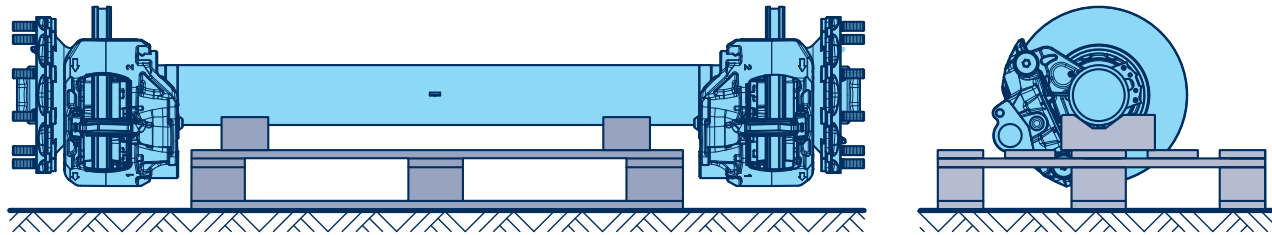

When transporting and storing the axles, a suitable rack or support should be used to avoid impacts, e.g. on the brake disk rim.

Otherwise, cracks may occur (brake discs must then be replaced immediately). The brake disc edge should be unloaded by the time the wheels are mounted. Wheels that are only required in-house during vehicle production should be mounted with at least 4 wheel nuts each and the intended torque.

3.7.2 Installation

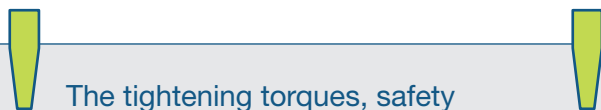

The tightening torques, safety instructions, care and maintenance specifications as well as information on component changing can be found in the workshop manual „BPW trailer axles with trailer disc brakes - ECO Disc” at www.bpw.de!

[Workshop manual TS2](#)

[Workshop manual TSB](#)

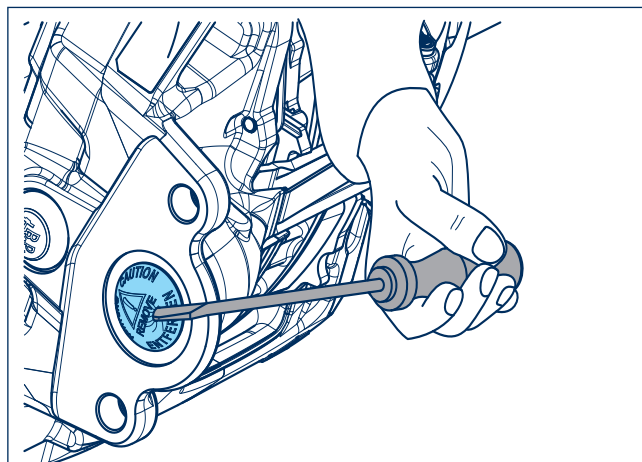

Before assembling the brake cylinder, remove the yellow/orange sealing cap.

Using a thin screwdriver, pierce the plug in the middle and lift the sealing cap out of the brake caliper.

Specifications for assembling the brake cylinder according to the workshop manuals:

"BPW Trailer Axles with Trailer Disc Brake ECO Disc" and "BPW Trailer Axles with Trailer Disc Brake ECO Disc TS2" at www.bpw.de.

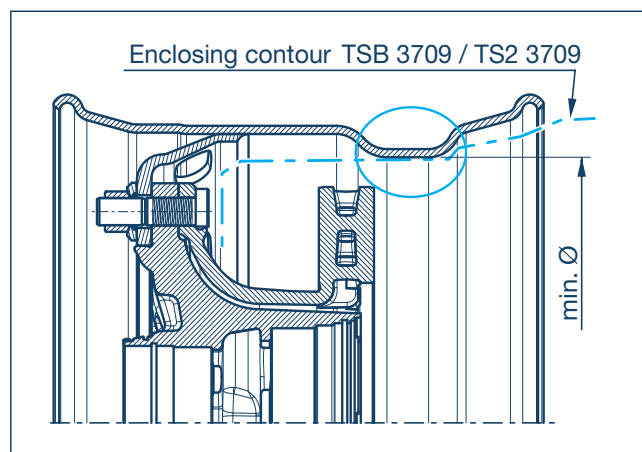

Only wheels with valves located outside the wheel disc and at least the following rim inside diameters are to be used:

TSB 3709 / TS2 3709:	min. Ø 418 mm
TSB 4309 / TS2 4309:	min. Ø 487 mm
TSB 4312:	min. Ø 490 mm

3.7.2 Installation

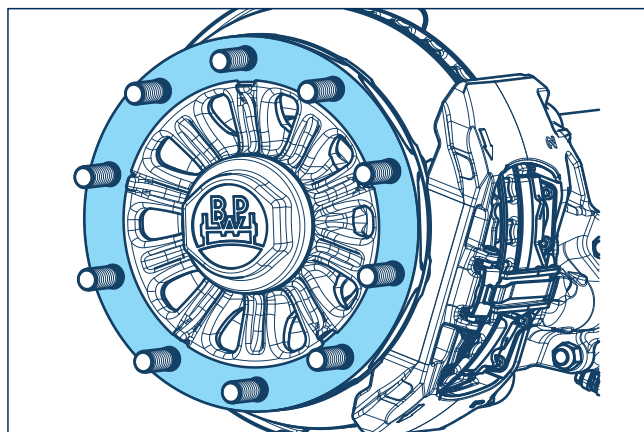
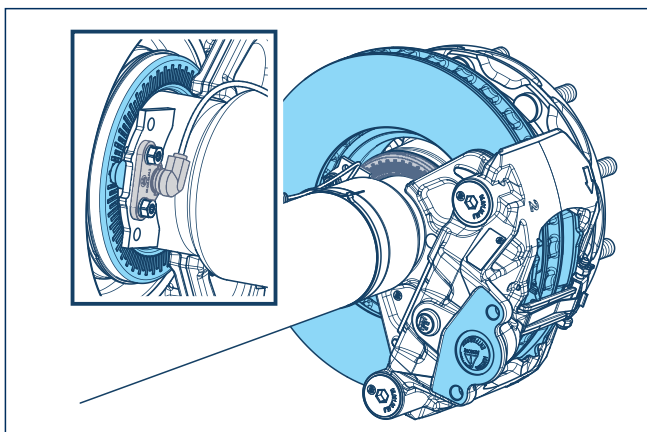

The following areas of the disc brake must be covered before any painting work:

- Brake disc
- Contact surface of the exciter rings, ABS sensor
- Brake lining shaft
- Brake cylinder contact surface for unmounted brake cylinders
- Wheel contact surfaces

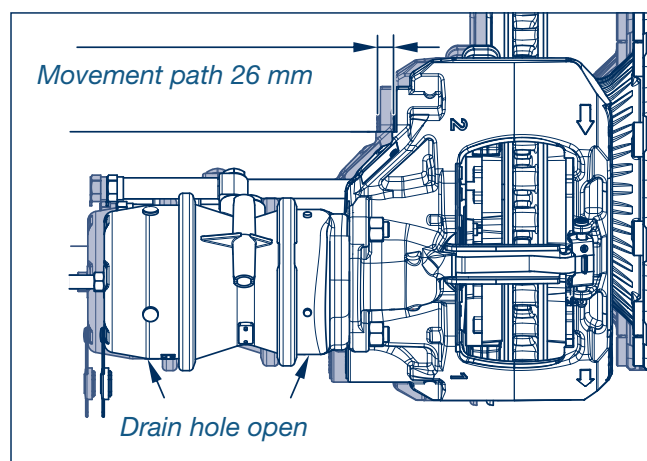

When disc brake axles are installed, ensure smooth movement of the floating calliper and all add-on pieces!

The displacement path is 26 mm to the center of the axle, depending on the brake pad wear.

Remove the lower vent plugs from the brake cylinder.

The ventilation line for diaphragm piston cylinders must be facing upwards.

3.7.2 Installation

Release device inserted. Spring mechanism released.

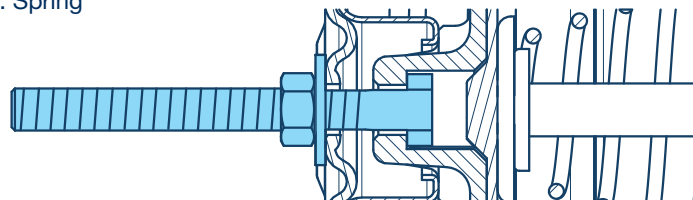

The brake cylinder release bolt must be installed in one of the two possible parking positions before vehicle is taken into operation.

Brake cylinders are usually delivered with released parking brake. When driving, the release bolt can be fixed in the keyhole of cylinder cover (cf. Figure) or the side fixture.

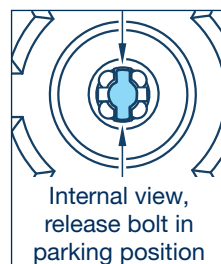
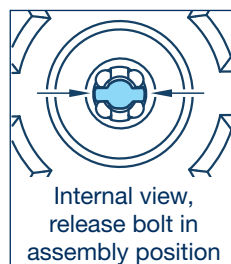

Release device in parking position,
Plastic sleeve and cap mounted.

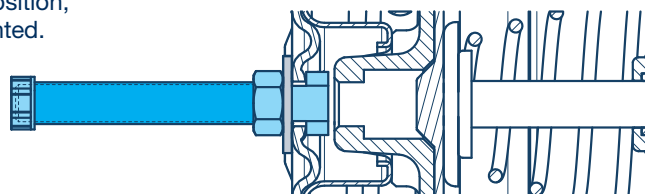

3.7.3 Brake pad wear sensing | General

Wear sensor set 05.801.48.92.0

BPW offers wear sensing for the TS2 based on the principle of sliding contacts. When the pads are worn to contact, a current flow is generated as a signal. This signal can be further processed in the EBS or by means of telematics.

The specifications of the respective EBS manufacturer must be observed when combining with the wear sensors.

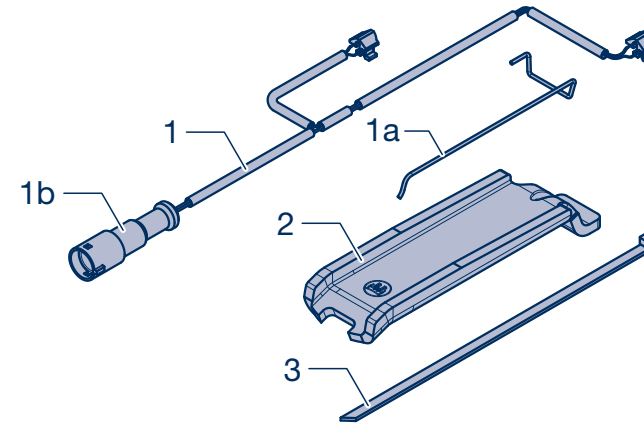

- | | | |
|----|--|---------------------------------|
| 1 | Break pad wear sensing
(cable with brake pad wear contacts and plugs) | 05.801.48.95.0 incl.
Item 1a |
| 1a | Retention clip | 03.001.00.77.0 |
| 2 | Brake pad retaining clip | 03.001.00.78.0 |
| 3 | Cable ties | 02.1809.08.00 |

3.7.3 Brake pad wear sensing | Installation

[Installation instructions wear sensing TS2](#)

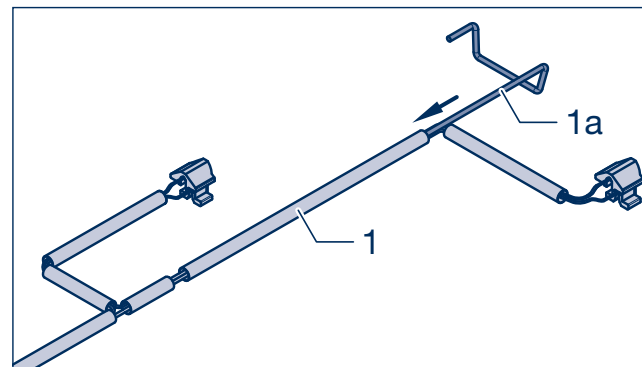

1. Pre-mount the retention clip (1a) in the protective sleeve of the cable (1) as shown.

3.7.3 Brake pad wear sensing | Installation



When mounting the retention clip (1a), make sure that the cables of the wear sensors are not trapped underneath!

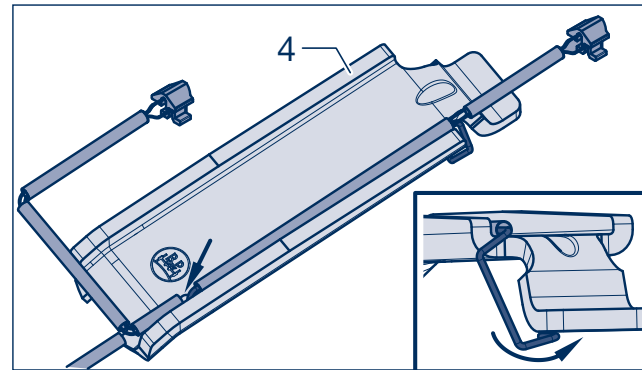

2. Insert the offset, long side of the retention clip into the bore hole in the pad retainer (2) (arrow).

Depress the retention clip slightly and roll over the long side so that the short side of the retention clip appears on the opposite side of the fastening strap.

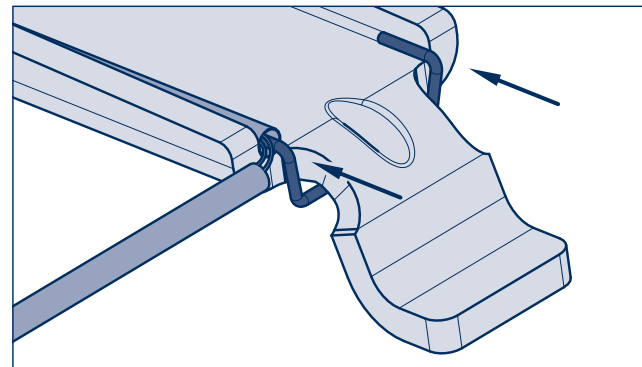

3. Push the retention clip onto the pad retainer in the direction of the arrow.

Ensure the retention clip is firmly seated on the pad retainer.

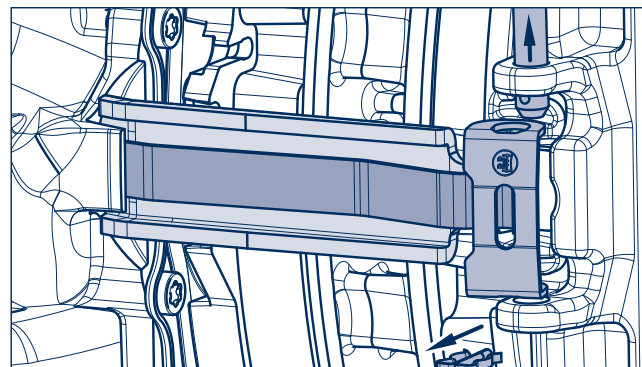

4. Pull the spring split pin out of the bolt.
5. Depress the clamping spring and remove the bolt with the retaining clamp.
6. Remove the pad retainer with clamping spring.

At the same time, make sure that the brake lining does not drop out of the lining slot.

3.7.3 Brake pad wear sensing | Installation



When assembling the clamping spring, make sure that the cables of the wear sensors are not trapped underneath.

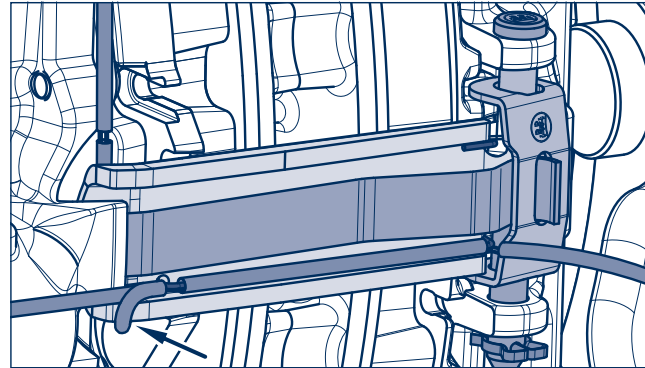

7. Mount the new pre-assembled pad retainer with brake pad wear sensing.

A cable must be passed under the pad retainer on the holder on the brake caliper (arrow).

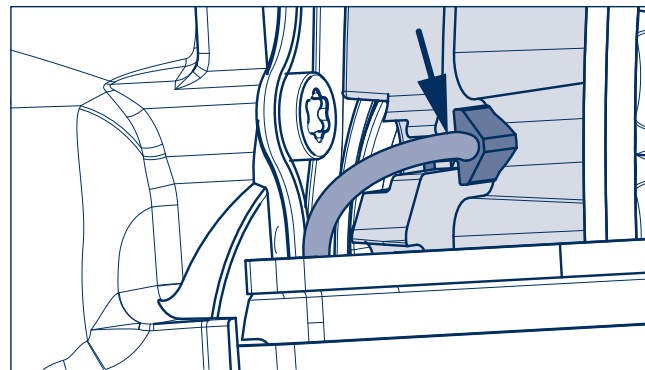

8. Clip the wear contacts into the recesses on the brake linings.



The cables must be fixed so that contact with the wheel or the rim is impossible.

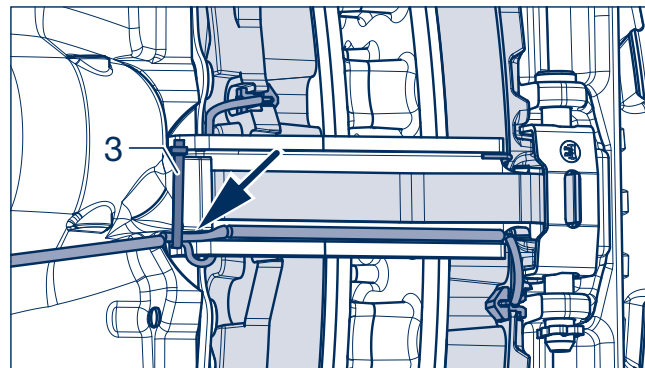

9. Fix the cable with a cable tie to the holder (3) for the pad retainer (arrow).
10. Fix the cable at the connector end to the compressed air hoses with a cable tie and make the cable connection.

3.7.3 Brake pad wear sensing | Assembly with brake lining - dust cover

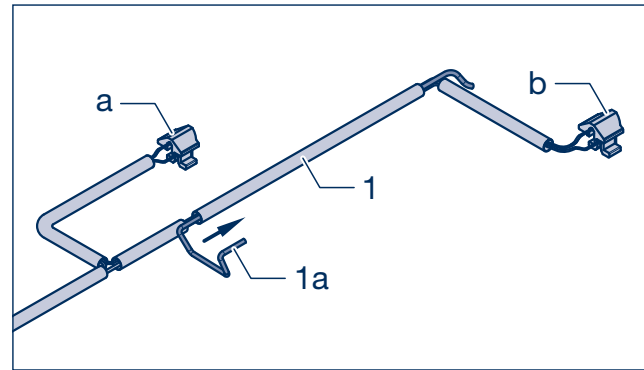

1. Pre-mount the retention clip (1a) in the protective sleeve of the cable (1) as shown (rotated 180° for the version without brake lining - dust cover).

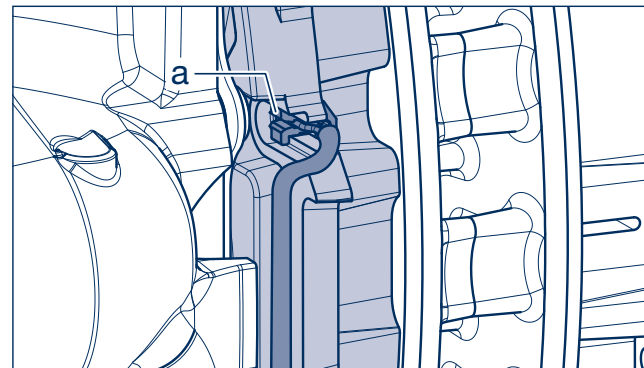

2. Mount the brake pad wear contact (a) on the internal active brake lining and guide the cable behind the brake lining to the other side and set aside.

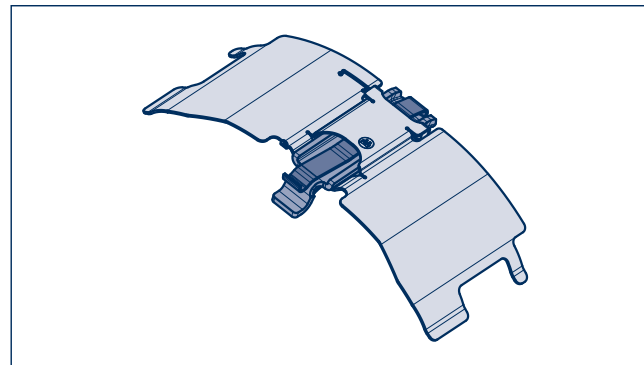

3. Pre-mount the pad retainer with the clamping spring on the brake lining - dust cover.

3.7.3 Brake pad wear sensing | Assembly with brake lining - dust cover



When assembling the brake lining - dust cover, make sure that the cables of the brake pad wear contacts are not trapped underneath.

The cable for the assembled brake pad wear contact (a, see step 2.) must be guided from the brake lining - dust cover to the position marked with an arrow.

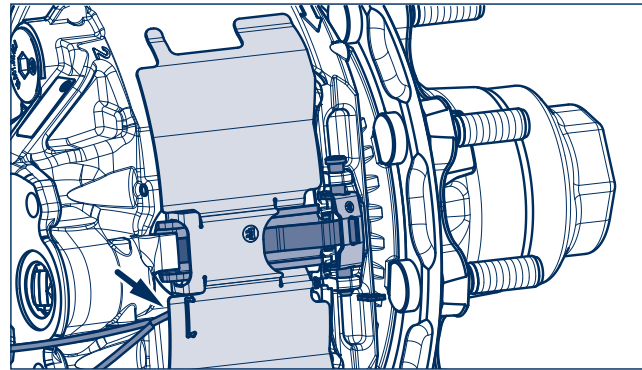

4. Mount the pre-assembled brake lining - dust cover on the brake caliper so that the pad retainer with clamping spring is inserted into the holder on the brake caliper.
5. Depress the pad retainer with clamping spring and attach the retaining clamp.
6. Insert the bolt and secure using the locking pin.



When assembling the brake lining - dust cover, make sure that the offset holder for the brake pad retaining clip (arrow) does not rest on the brake lining and that the sensor cable does not become trapped during assembly.

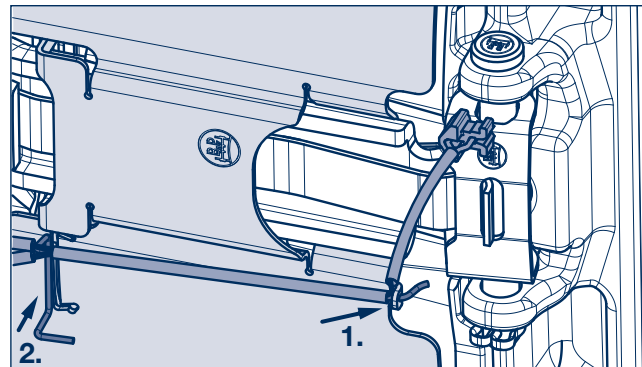
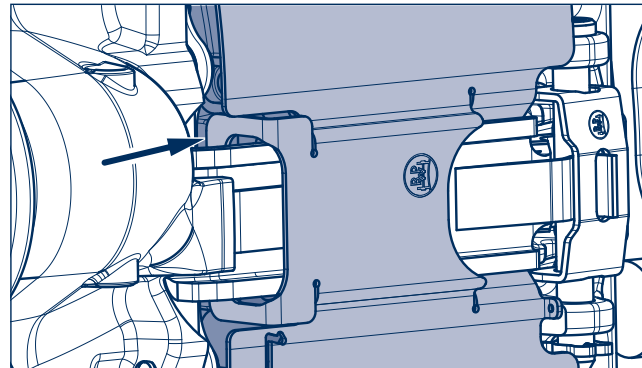

7. Insert the pre-assembled retention clip with brake pad wear sensing into the holder (arrow 1) on the brake lining - dust cover.
8. Insert the offset end of the retention clip into the slot in the brake lining - dust cover (arrow 2).

3.7.3 Brake pad wear sensing | Assembly with brake lining - dust cover



The cables must be fixed in such a way that contact with the wheel or the rim is impossible.

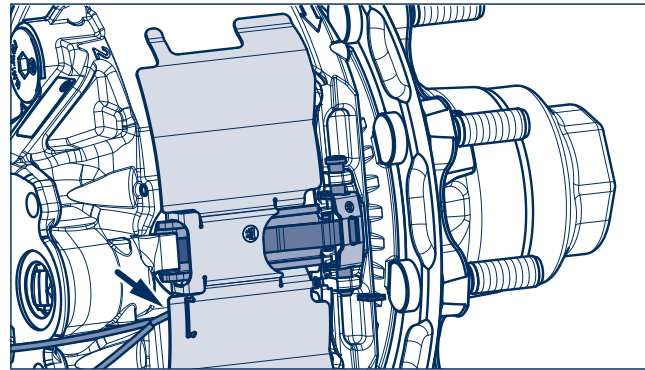

9. The retention clip is fixed to the brake lining - dust cover by squeezing the wire legs together and pushing them axially (arrow 3) as far as they will go.
10. Mount the outer brake pad wear contact (b) onto the outer, passive brake lining using a screwdriver, for example.
11. Use a cable tie to fix the cable to the holder (3) for the pad retainer and fix a cable tie to the brake lining - dust cover.
12. Fix the cable at the connector end to the compressed air hoses with a cable tie and make the cable connection.

3.7.4 Dust cover

BPW offers optional cover plates for the TS2 and also for the TSB 4312. These are common in off-road use or in Scandinavia in general and protect the brake from dirt as well as snow and ice.

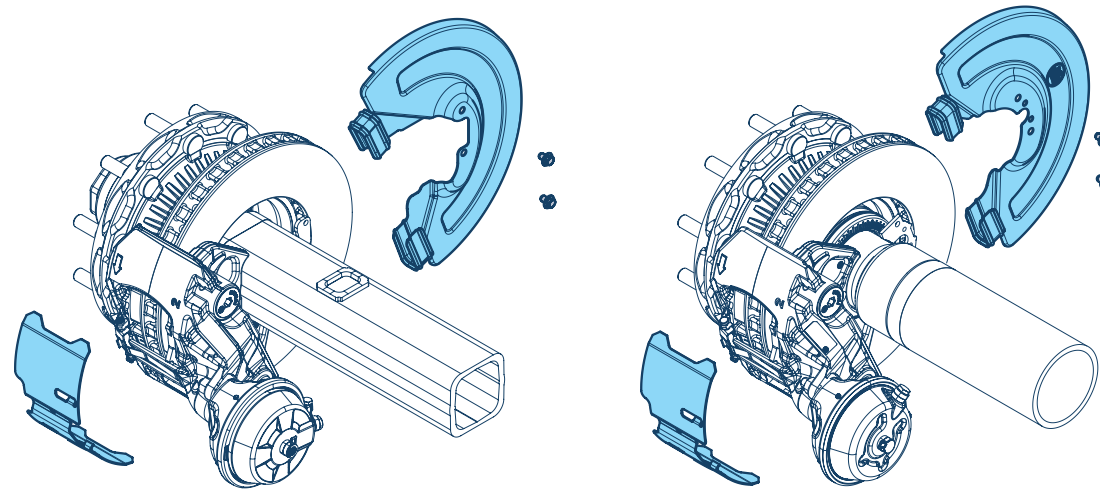

Example: BPW ECO Disc TS2 3709 / 4309 - Rigid axles

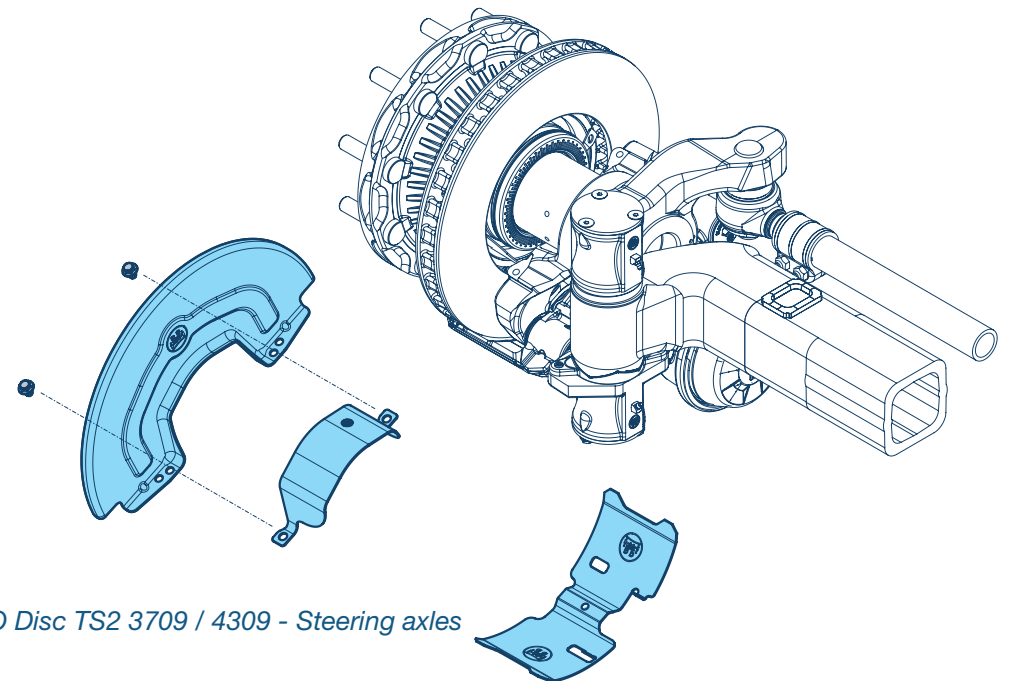

Example: BPW ECO Disc TS2 3709 / 4309 - Steering axles

3.7.4 Dust cover

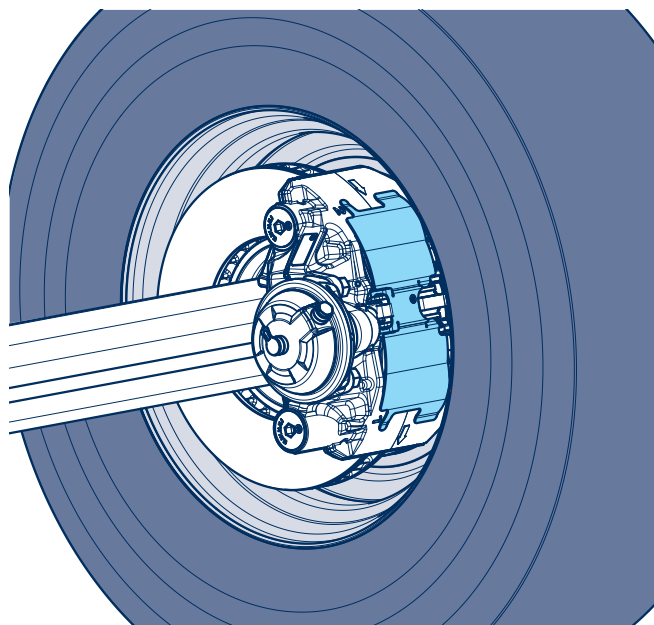

- Shaft cover plate 03.010.95.43.0 for brake TS2 3709 and TS2 4309 (for original equipment or retrofitting)
- Better protection of the brake pads and add-on parts against environmental influences and weathering during driving (on- and off-road)
- Recommended for the ET0 configuration of the TS2 disc brake

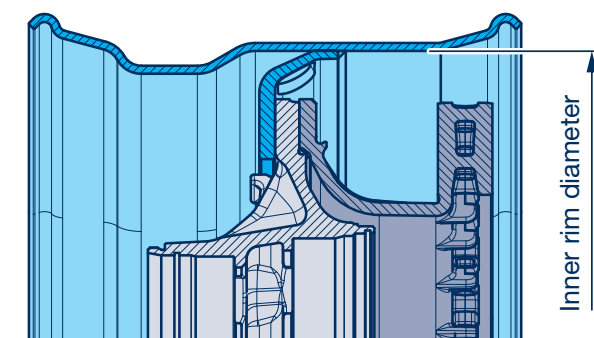

Specification for minimum inner rim diameter (with cover plate fitted, with or without pad wear sensing)

Brake	Offset 0		Offset 120	
	19,5" tyres	22,5" tyres	19,5" tyres	22,5" tyres
TS2 3709	Ø Rim _{inside} > 436 mm	Ø Rim _{inside} > 436 mm	Cover plate cannot be used	Ø Rim _{inside} > 436 mm
TS2 4309	-	Ø Rim _{inside} > 495 mm	-	Ø Rim _{inside} > 495 mm

3.8 Disc and drum brake: operating instructions

1. **To maintain the performance of the brake system, we recommend regular use of the wheel brakes with an appropriate thermal input (approx. 400°C for disc brakes and 200°C for drum brakes).**
2. **Longer periods of vehicle non-use with the parking brake engaged may cause the linings on the brake disc or brake drum to rust.**

Preventive measure:

- Warm up the brakes before shut-down, in order to park the brakes dry,
- Do not clean the vehicle with solvent cleaners before shut-down. This promotes corrosion on the metallic bright surfaces.
- Avoid vehicle shut-down with the parking brake engaged, if necessary use wheel chocks.

Measures before recommissioning:

- Test free running when the brake is released,
- If the wheel is blocked, despite the brake being released, dismantle the brake linings and clean or replace them (see workshop manual).

3. Possible measures to prepare the brakes before the main inspection (HU), safety inspection (SP) or a type 0 test of the vehicle.

For vehicle type approvals (vehicle homologations), further preparatory measures are required (consult BPW).

Step 1: Greasing the lubrication points (with drum brakes)

Step 2: Start-up

Brake	Brake lining	Number of braking operations	Time	Starting speed	End speed	Cylinder pressure	Final temperature of brake disc or brake drum
TSB 3709 TS2 3709	BPW 8200 BPW 8201	20 x	1 Min.	60 km/h	40 km/h	3 bar	Approx. 500°C
TSB 4309 TS2 4309	BPW 8200 BPW 8201	20 x	1 Min.	60 km/h	40 km/h	3 bar	Approx. 475°C
TSB 4312	BPW 8301	10 x	1 Min.	60 km/h	40 km/h	3 bar	Approx. 400°C
SN 300	T 090	5 x	1 Min.	60 km/h	40 km/h	3 bar	Approx. 200°C
SN 360	T 090	20 x	1 Min.	60 km/h	40 km/h	3 bar	Approx. 300°C
SN 420	T 090	5 x	1 Min.	60 km/h	40 km/h	3 bar	Approx. 200°C

Step 3: Clean the brake

Brake	Brake lining	Number of braking operations	Starting temperature	Starting speed	End speed	Cylinder pressure (alternating)	
TSB 3709 TS2 3709	BPW 8200 BPW 8201	not required					
TSB 4309 TS2 4309	BPW 8200 BPW 8201	20 x	Approx. 100°C	60 km/h	40 km/h	3 bar	
TSB 4312	BPW 8301	10 x	Approx. 100°C	60 km/h	40 km/h	2 / 4 bar	
SN 300	T 090	not required					
SN 360	T 090	10 x	Approx. 100°C	60 km/h	40 km/h	2 / 4 bar	
SN 420	T 090	10 x	Approx. 100°C	60 km/h	40 km/h	2 / 4 bar	

4. In the case of early brake wear, carry out a truck-trailer harmonization (ISO 20918).

The following are available for assembly at a later date:

- Wear sensing (s/w) for connection to BPW Brake Monitor or EBS:
TSB disc brake: 05.801.50.38.0 (observe installation instructions 04.00.539017),
TS2 disc brake: 05.801.48.92.0 (observe installation instructions 04.00.572105),
Drum brake: 05.801.50.05.0 (observe installation instructions 04.001.21.22.0).
- Shaft cover for disc brakes in off-road use:
Disc brake TSB: 03.010.95.32.0

5. Observe this for new vehicles and/or after a brake service

The braking effect of new brake drums and brake discs or pads is only at its optimum after a few braking actions. Therefore, run in new brake pads. This involves avoiding lengthy application of the brakes and unnecessarily sharp braking.

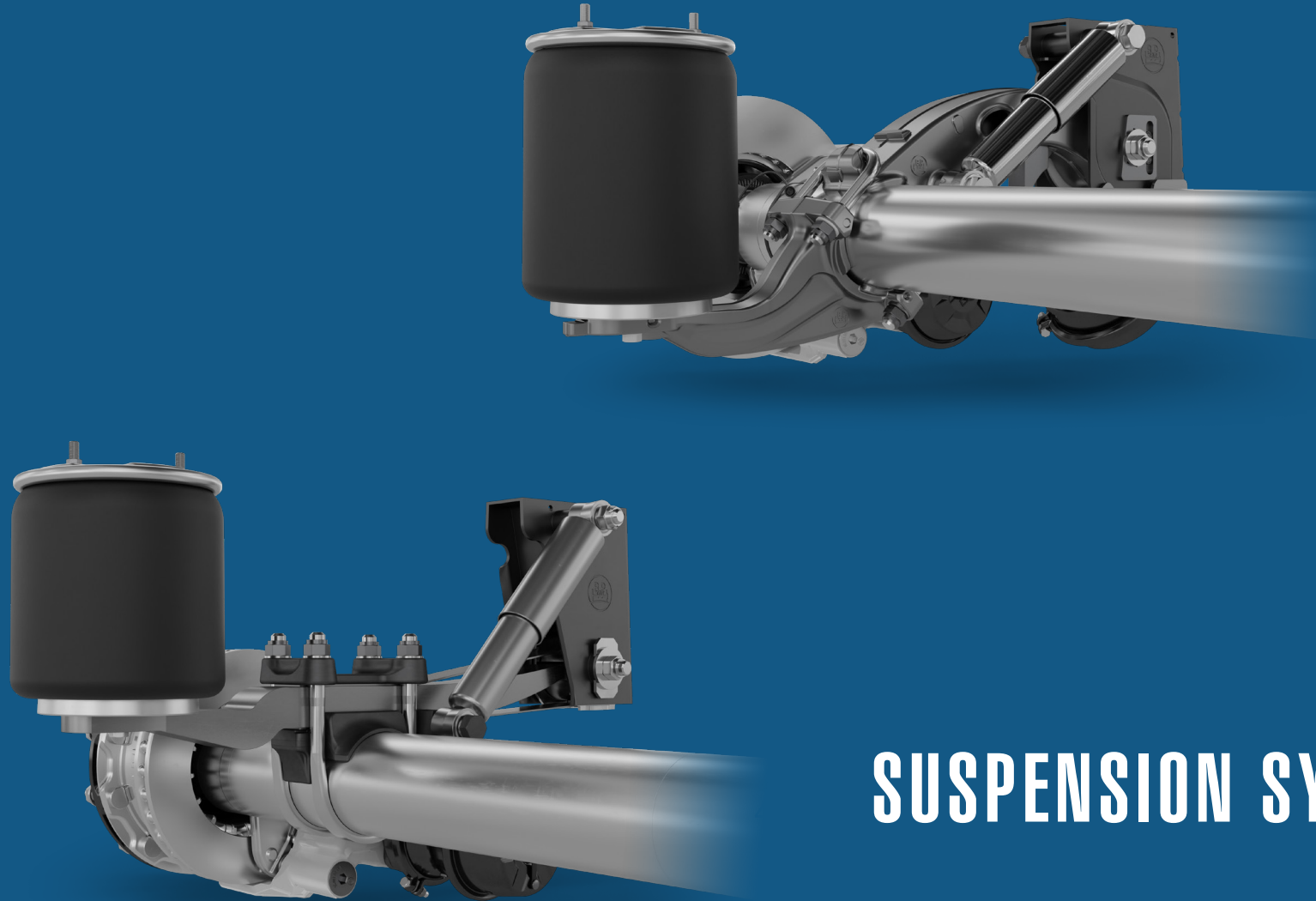

4

SUSPENSION SYSTEMS

4.1 Air suspension ECO Air

4.2 Air suspensions Air-light II and SL

4.3 Mechanical suspension ECO Cargo VB

4.4 Mechanical suspension ECO Cargo W

4.1 Air suspension ECO Air

4.1.1 Notes, design, system kit | Notes on content

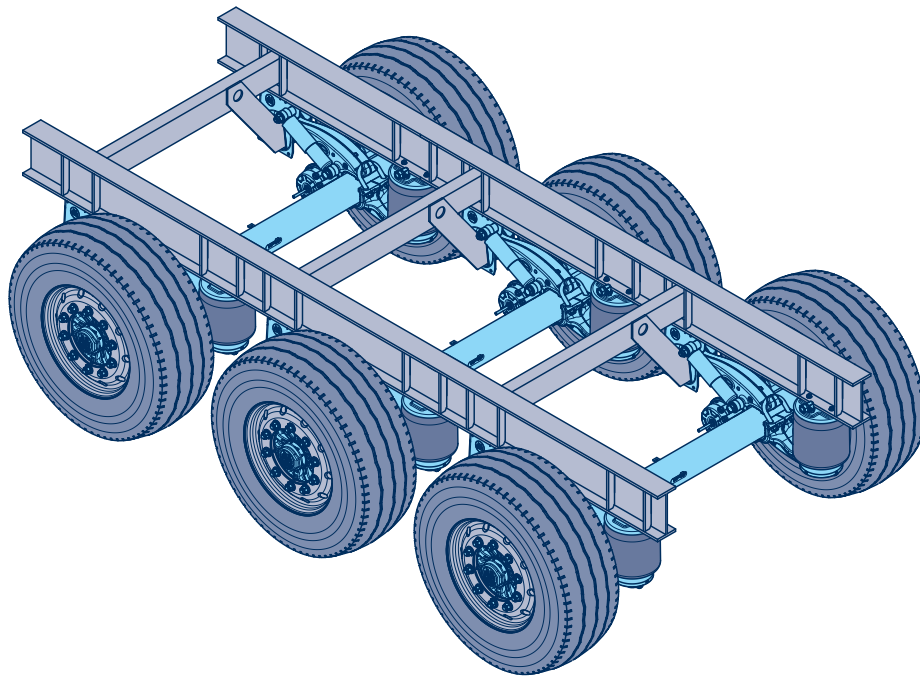

Overview of the air suspension series
[see chapter 1.2.3](#)

With this chapter we would like to present the technical guidelines of the design and give installation recommendations.

Please note that the drawings in the guidelines are examples only and dimensions depend exclusively on the vehicle type and its operating conditions. This data is only known to the vehicle manufacturer who must incorporate it in their design.

The formulas and calculation examples listed by BPW are used to estimate the various forces. The safety factors for the constructional design of the vehicle frame and substructure must be defined by the vehicle manufacturer.

Detailed design data for and characteristics of BPW air suspensions such as dimensions, permitted centre of gravity, etc. can be found in the technical documents (air suspension data sheets and offer drawings).

The warranty shall lapse if installation of the BPW running gear system does not correspond to technical guidelines as per current BPW installation instructions. The BPW warranty is only valid for the complete ECO Plus air-suspended running gear systems, which have been selected appropriately for their respective use.

For further information, please refer to the current valid service and maintenance instructions or the ECO Plus Guarantee brochure.

[Maintenance instructions](#)

[ECO Plus Warranty documents](#)

4.1.1 Notes, design, system kit | Features of the ECO Air running gear systems

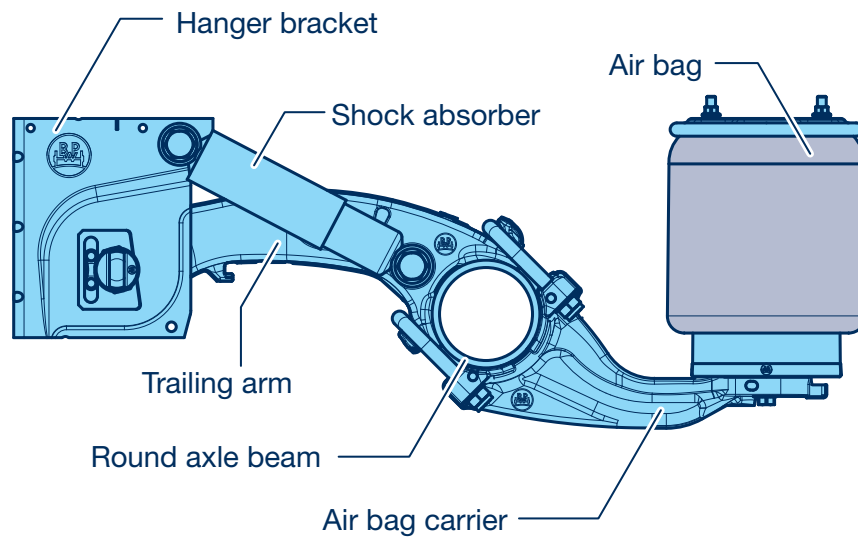

- Axle load up to 9t with single wheels
- Approved for on-road and off-road use
- Disc brake ECO Disc (ET120)
TS2 3709
TS2 4309
- Drum brake ECO Drum
SN 4218
- Track setting through standard adjustable hanger brackets
- Spring bolt M 24
- Hanger brackets with heights of 205 mm and 290 mm
- Trailing arm with steel rubber bushing

4.1.1 Notes, design, system kit | System kit

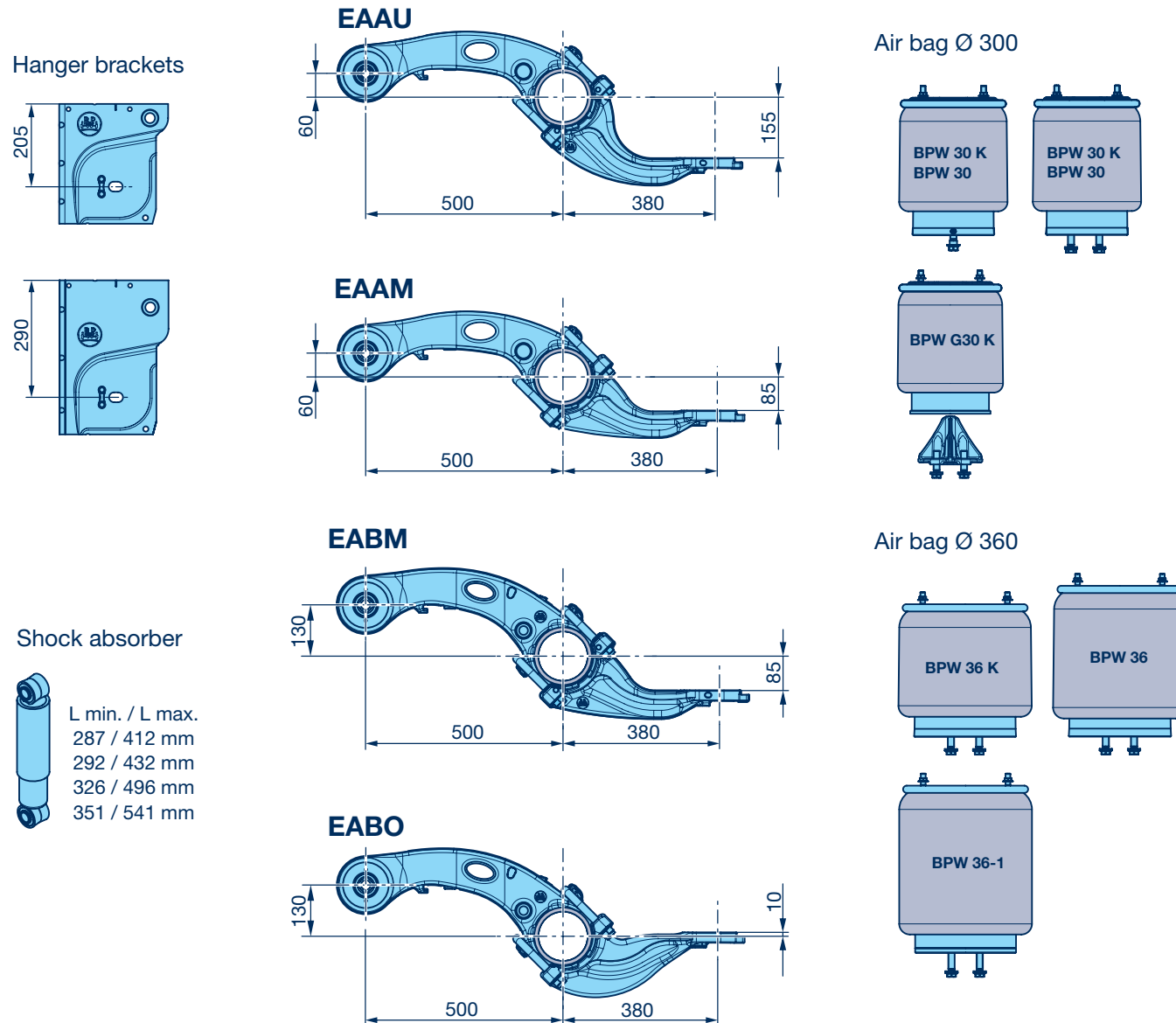

4.1.1 Notes, design, system kit | Design description

General

The combination of axle and air suspension (axle-suspension unit) can be used as single and multiple unit in the vehicle. The modular BPW concept of the multi-part axle - trailing arm assembly allows maximum adaptation options. The integrated vertical stop (bump stop in the air bag) ensures that the connection of the running gear to the vehicle frame only has to be created through the hanger brackets and air bags.

Trailing arm and stabilizer function

The trailing arms (between axle and hanger brackets) transmit the wheel forces to the hanger bracket and are designed to be bending resistant. The trailing arm bearing in the hanger bracket contains a large durable rubber bushing. Whilst air suspension is used for the vertical movement, the body rolling of the vehicle and one-sided driving through dips or obstacles are compensated by the trailing arm bearing (body rolling suspension). The U-shape configuration of axle beam and two trailing arms acts as a stabilizer to counteract the side tilt of the vehicle during lateral acceleration.

Axle and brake load equalisation

All air bags are connected with one another through air pipes. Uneven driving surfaces or vehicle tilts therefore do not create different axle loads within the multiple axle-suspension unit. The brake forces are also evenly distributed across all axles. BPW air suspension running gear systems therefore provide maximum driving safety and minimal tyre wear.

Suspension and shock absorbers

To achieve the optimal combination of safe and comfortable driving and minimal wear, the air bags and shock absorbers are perfectly matched up with their characteristic curves and installation diagrams. The oscillating movement (vertically and body roll) is absorbed effectively and the wheels retain optimal road contact.

Vertical, longitudinal and lateral forces

The vertical forces are distributed across hanger brackets and air bags. Longitudinal forces (from uneven road surfaces and due to braking) as well as lateral forces, on the other hand, are exclusively applied to the vehicle frame through the hanger bracket. Without an adjusted brace, which must be professionally made by the vehicle manufacturer, the lateral forces cannot be transferred from the hanger bracket to the frame.

4.1.1 Notes, design, system construction kit | Design description

Raising and lowering; axle lift device

The air suspension facilitates the quick adjustment of the ride height through a switch or rotary disc valve for various loading and unloading processes. This typically involves adjustment to loading ramps or lowering for safe tilting. The also optional axle lift device (axle lift) for one or several axles makes it possible to influence the axle load distribution in an articulated truck and also the turning circle required. Tyre wear and fuel consumption are also reduced on trips with partial loads and manoeuvrability is improved.

Installation and alignment

BPW running gear components are designed for the simplest possible installation and maintenance. A tracking device integrated into the hanger bracket allows quick adjustment of the wheel track if necessary. BPW provides a tack welding device for initial installation, [see page no. 145](#), for optimally positioning hanger brackets and air bag brackets.

4.1.2 Force calculations | Straight line travel

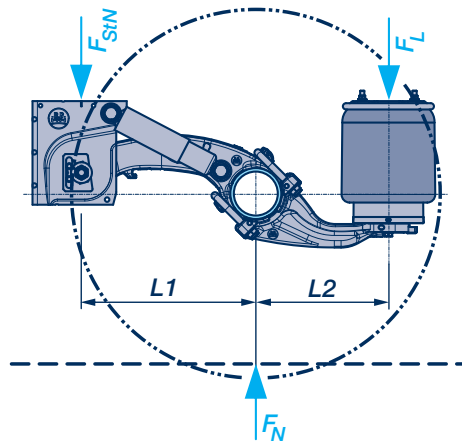

Driving mode straight ahead:

(without consideration of unsprung masses)

$$F_A = G_A \times g$$

$$F_N = \frac{F_A}{2}$$

$$F_{StN} = F_N \times \frac{L2}{L1 + L2}$$

$$F_L = F_N \times \frac{L1}{L1 + L2}$$

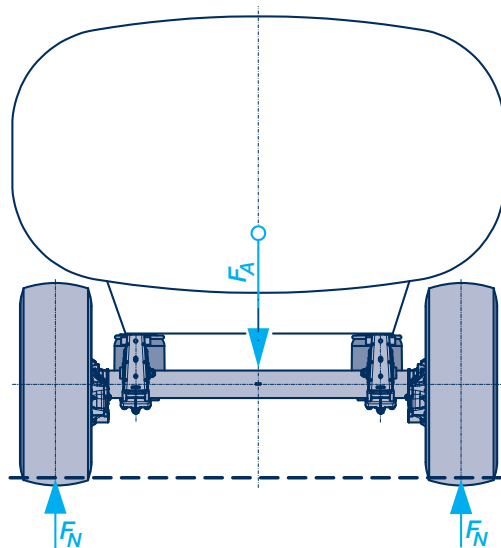

G_A = Axle load (kg)

g = Gravitational acceleration (9.81 m/s²)

F_A = Axle load (N)

F_N = Wheel force on ground (N)

$L1$ = Length trailing arm (mm)

$L2$ = Length air bag carrier (mm)

F_{StN} = Hanger bracket force from wheel force on ground (N)

F_L = Force on air bag (N)

Example:

SRBFEAAM 9010 V 30K ECO Plus 3

$$L1 = 500 \text{ mm}$$

$$L2 = 380 \text{ mm}$$

$$F_A = 9,000 \text{ kg} \times 9.81 \text{ m/s}^2 = 88,290 \text{ N}$$

$$F_N = \frac{88,290 \text{ N}}{2} = 44,145 \text{ N}$$

$$F_{StN} = 44,145 \text{ N} \times \frac{380}{500 + 380} = 19,063 \text{ N}$$

$$F_L = 44,145 \text{ N} \times \frac{500}{500 + 380} = 25,082 \text{ N}$$

4.1.2 Force calculations | Forces during braking

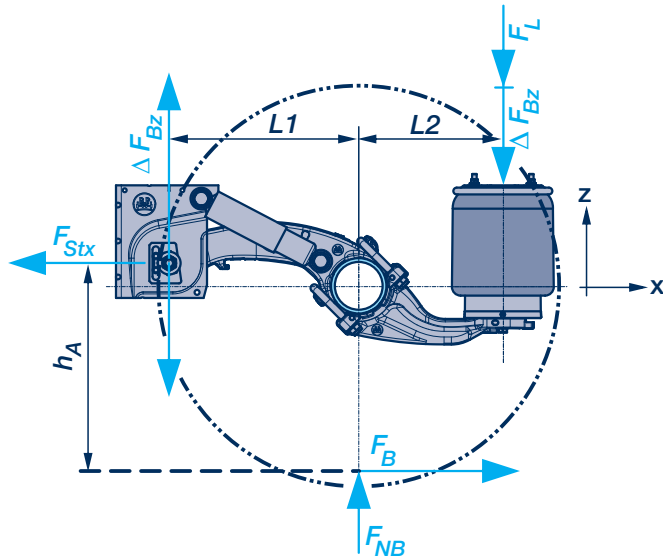

F_{NB} = Wheel force on ground during braking (N)

ΔF_A = Axle load shift during braking (N)
(depends on vehicle design, particularly important for trailer front axles)

F_{StN} = Hanger bracket force from wheel force on ground (N)

F_L = Force on air bag (N)

F_B = Braking force (N)

z = Braking rate (%)

ΔF_{Bz} = Reaction force from braking torque support (N)

h_A = Height of spring bolt over road surface

F_{Stx} = Total force on the hanger bracket in x-direction (N)

F_{Stz} = Total force on the hanger bracket in z-direction (N)

$F_{Lges.}$ = Total force on the air bags (N)

Normal forces from axle load:

$$F_{NB} = \frac{F_A \pm \Delta F_A}{2}$$

$$F_{StN} = F_{NB} \times \frac{L2}{L1 + L2}$$

$$F_L = F_{NB} \times \frac{L1}{L1 + L2}$$

Brake force:

$$F_B = \frac{z}{100} \times F_{NB}$$

Forces from braking torque support:

$$\Delta F_{Bz} = \frac{F_B \times h_A}{L1 + L2}$$

Total force on the hanger bracket in direction x:

$$F_{Stx} = F_B$$

Total force on the hanger bracket in direction z:

$$F_{Stz} = F_{StN} - \Delta F_{Bz}$$

Total force on the air bag:

$$F_{Lges.} = F_L + \Delta F_{Bz}$$

Example:

SRBFEAAM 9010 V 30K ECO Plus 3

$$F_A = 88,290 \text{ N}$$

$$\Delta F_A = \text{Assumed in Example 0}$$

$$F_{NB} = \frac{88,290 \text{ N}}{2} = 44,145 \text{ N}$$

$$F_{StN} = 44,145 \text{ N} \times \frac{380}{500 + 380} = 19,063 \text{ N}$$

$$F_L = 44,145 \text{ N} \times \frac{500}{500 + 380} = 25,082 \text{ N}$$

$$z = 80 \%$$

$$F_B = 0.8 \times 44,145 \text{ N} = 35,316 \text{ N}$$

$$h_A = 600 \text{ mm}$$

$$\Delta F_{Bz} = \frac{35,316 \text{ N} \times 600}{880} = 24,079 \text{ N}$$

$$F_{Stx} = 35,316 \text{ N}$$

$$F_{Stz} = 19,063 \text{ N} - 24,079 \text{ N} = -5,016 \text{ N}$$

$$F_{Lges.} = 25,082 \text{ N} + 24,079 \text{ N} = 49,161 \text{ N}$$

4.1.2 Force calculations | Cornering

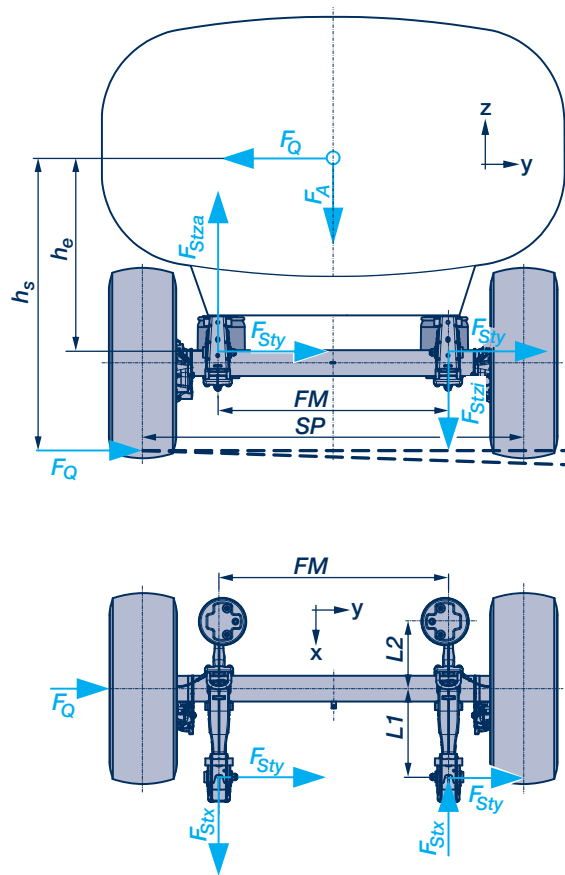

F_A = Axle load (N)

F_Q = Centrifugal force at the tilting limit (N)

F_{Stza} = Hanger bracket force at curve outer side (N)

F_{Stzi} = Hanger bracket force at curve inner side (N)

h_s = Centre of gravity height above road surface

h_e = Centre of gravity height above trailing arm bolt

Driving at the tilting limit:

(without considering effect of springs and weight of unsprung masses; proximity calculation)

$$F_Q = \frac{F_A \times SP}{h_s \times 2} = \frac{F_A}{g} \times a_{quer}^*$$

Hanger bracket forces:

$$F_{Stza} = \left(\frac{F_A}{2} \times \frac{L2}{L1 + L2} \right) + \frac{F_Q \times h_e}{FM}$$

$$F_{Stzi} = \left(\frac{F_A}{2} \times \frac{L2}{L1 + L2} \right) - \frac{F_Q \times h_e}{FM}$$

$$F_{Sty} = \frac{F_Q}{2} \text{ (Assumption)}$$

$$F_{Stx} = \pm \frac{F_Q \times L1}{FM}$$

* BPW can provide an accurate a_{quer} calculation in accordance with ECE R 111 on request (tilting stability calculation).

The track width and centre of gravity height have the main influence on the tilting angle. The calculation also accounts for the geometrical running gear design (trailing arm, roll centre) as well as the rigidity of trailing arm, axle beam, air bags and tyres. The lateral acceleration at the tilting limit and vehicle body tilting angle are the result of the calculation.

F_{Sty} = Lateral force on the hanger bracket

F_{Stx} = Longitudinal force on the hanger bracket

FM = Spring centre

SP = Track width

g = Gravitational acceleration (9.81 m/s²)

a_{quer} = Lateral acceleration at the tilting limit (m/s²)

Example:

SRBFEAAM 9010 V 30K ECO Plus 3

SP = 2,040 mm

FM = 1,300 mm

h_s = 2,000 mm

h_e = 1,400 mm

F_A = 88,299 N

L1 = 500 mm

L2 = 380 mm

$$F_Q = \frac{88,290 \text{ N} \times 2,040}{2,000 \times 2} = 45,028 \text{ N}$$

$$F_{Stza} = \left(\frac{88,290 \text{ N}}{2} \times \frac{380}{880} \right) + \frac{45,028 \text{ N} \times 1,400}{1,300} = 67,554 \text{ N}$$

$$F_{Stzi} = \left(\frac{88,290 \text{ N}}{2} \times \frac{380}{880} \right) - \frac{45,028 \text{ N} \times 1,400}{1,300} = -29,429 \text{ N}$$

$$F_{Sty} = \frac{45,028 \text{ N}}{2} = 22,514 \text{ N (Assumption)}$$

$$F_{Stx} = \pm \frac{45,028 \text{ N} \times 500}{1,300} = \pm 17,318 \text{ N}$$

4.1.2 Force calculations | Turning when stationary

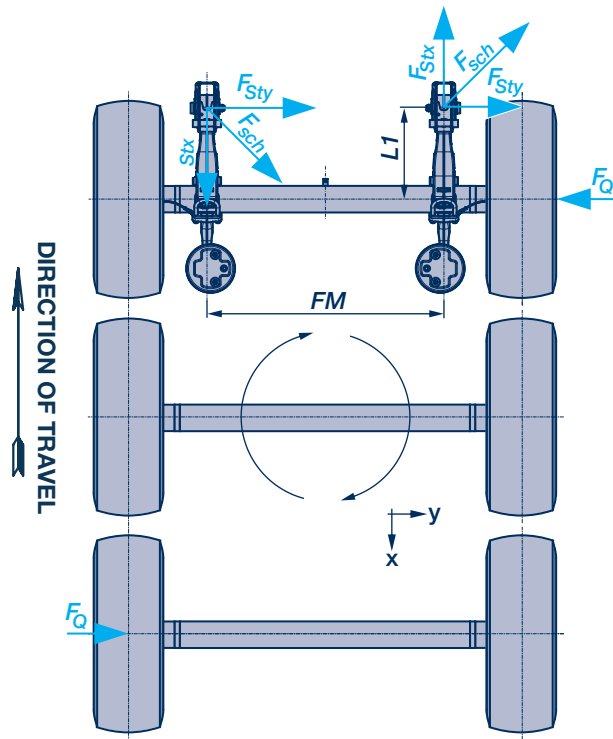

1st or 3rd axle in a rigid tri-axle-suspension

The lateral forces are transferred through the two outer axles. The central axle turns on its own axis and does not transmit lateral forces.

$$F_Q = F_A \times \mu_Q$$

$$F_{Stx} = \frac{+F_Q \times L1}{-FM}$$

$$F_{Sty} = \frac{F_Q}{2} \text{ (Assumption)}$$

Example:

SRBFEAAM 9010 V 30K ECO Plus 3

$$FM = 1,300 \text{ mm}$$

$$L1 = 500 \text{ mm}$$

$$F_A = 9,000 \text{ N} \times 9.81 = 88,290 \text{ N}$$

$$\mu_Q = 1.6$$

$$F_Q = 88,290 \text{ N} \times 1.6 = 141,260 \text{ N}$$

$$F_{Stx} = \frac{141,260 \text{ N} \times 500}{1,300} = 54,331 \text{ N}$$

$$F_{Sty} = \frac{141,260 \text{ N}}{2} = 70,630 \text{ N}$$

F_{sch} = Resulting shear force (N)

F_Q = Lateral force on axle (N)

μ_Q = Traction coefficient when turning
(from tests: $\mu_Q = 1.6$)

4.1.3 Installation and welding specifications of hanger brackets

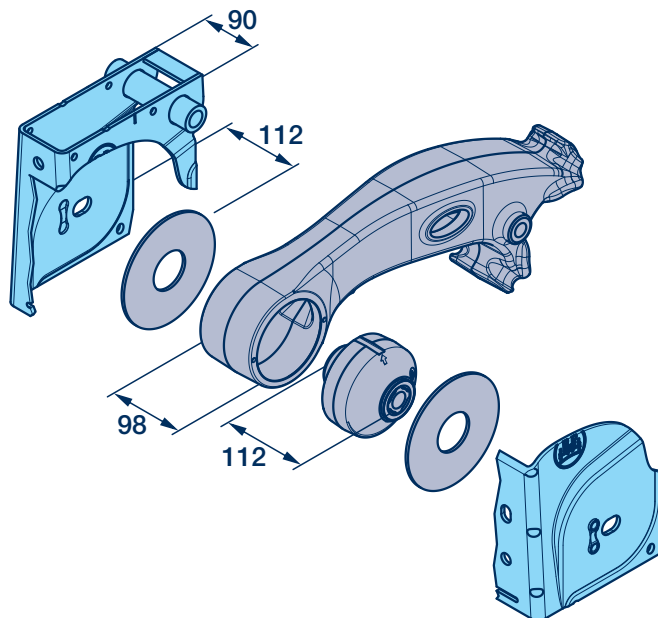
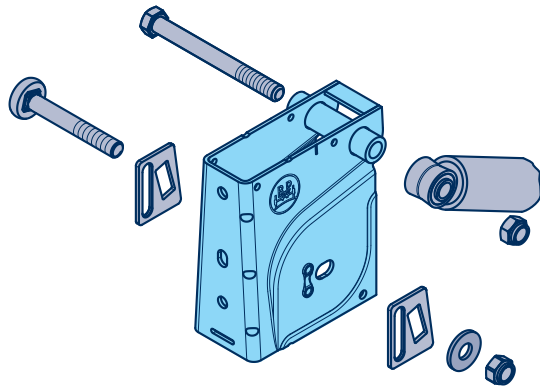

ECO Air hanger brackets

It is easy to connect the rectangular smooth surfaces with the vehicle frame and weld on transverse braces.

Together with the low hanger bracket height, the modular design provides extremely high torsional rigidity. Braces can therefore be easily connected.

- Fastening to the vehicle bottom flange by welding
- Trailing arm 98 mm wide (bushing 112 mm), upper hanger bracket width 90 mm
- Upper shock absorber attachment with screw and lock nut
- With integrated track adjustment, spring bolt diameter \varnothing 24 mm (see [chapter 4.1.8](#))

4.1.3 Installation and welding specifications of hanger brackets

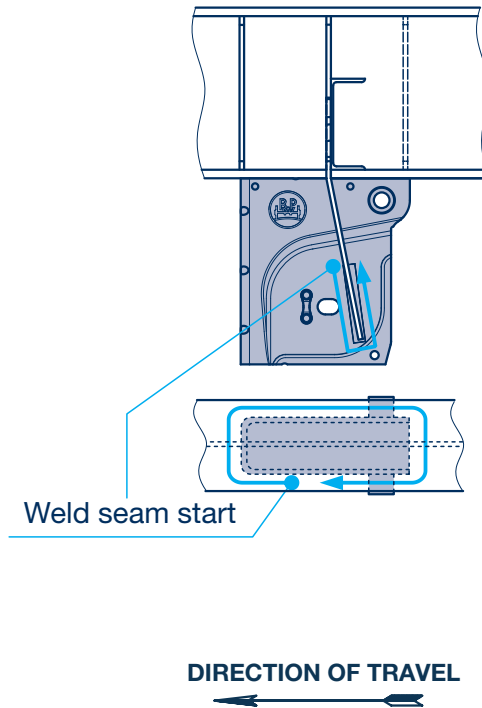

Welding process

(Welding of the hanger brackets on the vehicle frame)

- Gas shielded arc welding
Weld wire quality G 4 Si 1 – EN ISO 14341-A
- Manual arc welding
Stick electrodes E 46 5 B 32 H 5 – EN ISO 2560-A

Mechanical properties must correspond to base material S 420 or S 355 J 2 Seam thickness a 4 ∇ (DIN EN ISO 5817 Evaluation group C)

Avoid end craters and undercuts!



The general state-of-the-art regulations must be complied with when welding.

Functional surfaces are free from weld spatter.

During all welding work, the trailing arms, air bag carriers, U-bolts, air bags, shock absorbers as well as plastic pipings must be protected against sparks and weld splatter.

The earth terminal must under no circumstances be attached to the trailing arms, air bag carriers, U-bolts or hub.

No welds on trailing arm or air bag carrier.

It is not permitted for the hanger brackets to be heated for straightening work!

Use new spring bolts and lock nuts when replacing hanger brackets.

4.1.3 Installation and welding specifications of hanger brackets

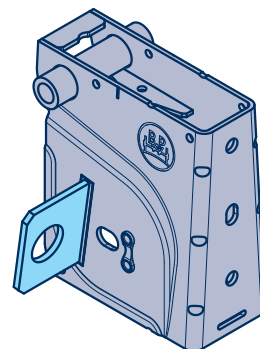
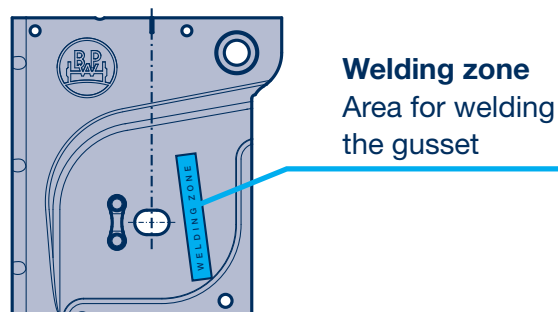
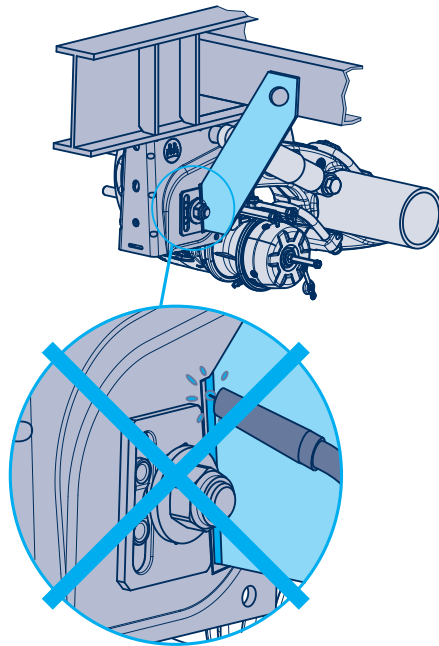

ECO Air Hanger brackets

A so-called **welding zone** is stamped on both sides of ECO Air hanger brackets.

To ensure optimum flow of forces, braces are to be welded to the hanger bracket in this area only.

Each hanger bracket must be braced with a gusset plate.

Attention: In case of welded gussets, do not select any other position on the hanger bracket than the one resulting from the Welding Zone.

BPW tack welding device *see page no. 145*



Cross braces must not be welded to the hanger bracket with the trailing arms mounted, as the plastic wear plates between trailing arm and hanger bracket can be damaged by the high heat. In this case, bolted-on gusset plates (*see chapter 4.1.4*) or hanger brackets with welding lugs (see below) can be used.

Hanger bracket with welding lugs

Hanger brackets with welding lugs are supplied on request. Without detaching the connection trailing arm / hanger bracket (spring bolt) a brace can be connected to this via plug welding.

When welding on hanger brackets with shock absorbers fitted, ensure that suitable welding protection is used.

4.1.3 Installation and welding specifications of hanger brackets

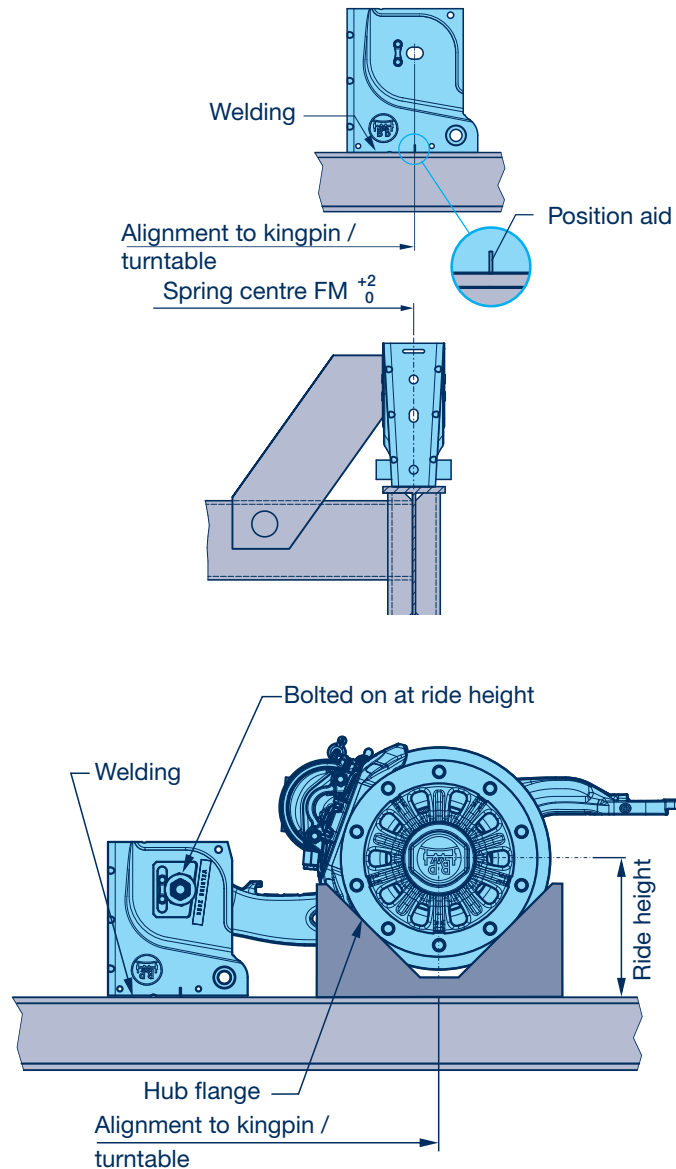

As a rule, air suspension axles are installed with the vehicle frame on its back.

Welding on loose hanger brackets

In ECO Air running gear systems with loose hanger brackets, the hanger brackets are welded to the vehicle frame first.

The spring bolt bearing points of the hanger brackets are positioned precisely to the longitudinal centre line of the vehicle using the centre of kingpin or turntable.

As a positioning aid, there is a marking (embossing) just above the spring bolt eye in the upper area of the hanger bracket. In this case, the spring bolt mounting points of the hanger brackets are aligned in relation to the longitudinal centre line of the vehicle taken from the middle of the kingpin or steering turntable.

In this installation position, the tolerances of the spring centres and the lengths of the trailing arm and air bag supports must be taken into consideration.

The hanger bracket position in the sideways direction must be kept within the tolerance range FM (0, +2) to avoid stresses in the axle-suspension unit. The gussets can then be welded on.

Check the axle alignment and correct if necessary after welding on the hanger brackets or mounting the axles (Alignment, [see chapter 4.1.8](#)).

Installation of pre-assembled air spring modules

ECO Air running gear systems with assembled trailing arms and hanger brackets are generally incorporated at the hub flange, arranged according to the vehicle design and aligned precisely to the longitudinal centre line of the vehicle using the centre of kingpin or turntable.

The hanger brackets are welded to the bottom flange of the vehicle frame.

4.1.3 Installation and welding specifications of supports | Tack welding and track setting device

For the quick and precise positioning of hanger brackets and air bag plates, BPW offers a special device which can be used to fix the components onto the frame with a high degree of positional accuracy.

To do this, the vehicle frame of the trailer is first built with the underside facing upwards. The fixing device consists of a rigid, stable aluminium frame with clamping and positioning devices for various air suspension hanger brackets and air bag plates and is placed on the vehicle frame.

After the alignment to the kingpin using a laser, the device is clamped between the longitudinal beams.

Six air suspension hanger brackets and air bag plates are simultaneously placed on the frame for fixing through appropriate fitting holders.

Once the device is removed, the hanger brackets and air bag plates can be welded on.

The subsequent attachment of the air suspension unit will ideally enable the omission of the additional tracking process, since the axles are already in alignment with each other and with the kingpin through the defined position of the hanger brackets.

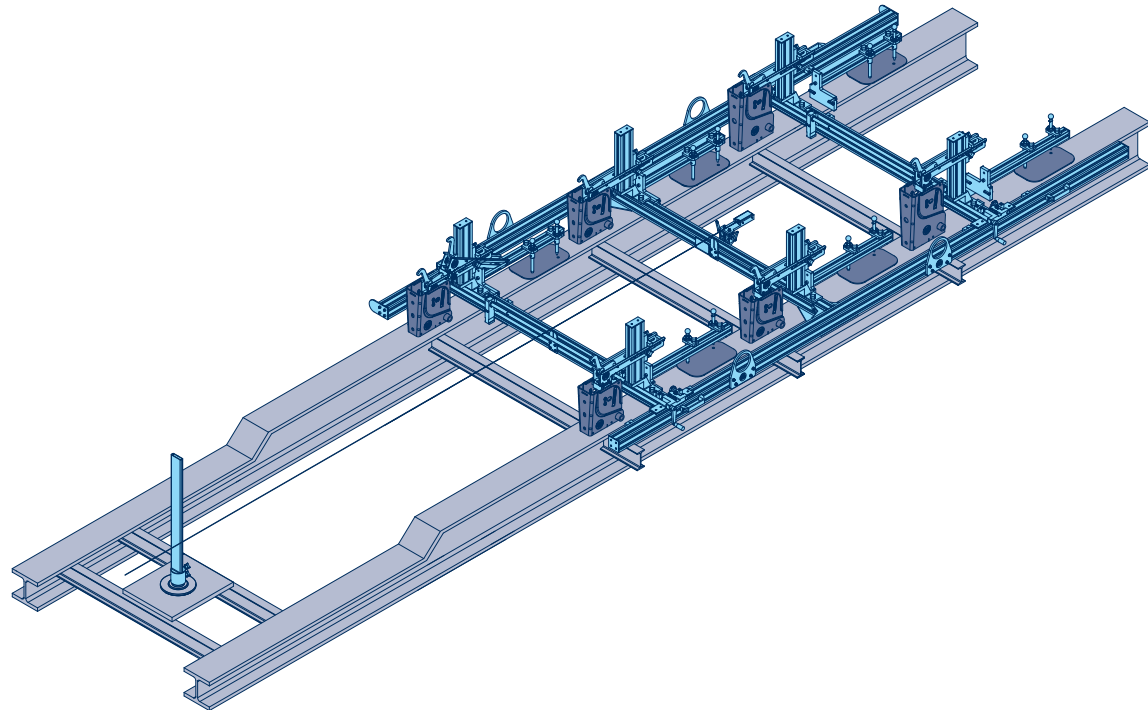

[Tack welding device in Youtube](#)

4.1.4 Hanger bracket gusseting | Welded gusset plates

Example of a general bracing proposal with gusset plates

With vehicle frames that are subject to torsion, a corresponding elastic and torsional brace on the hanger brackets is particularly necessary.

1. Crossmember

The forces created when travelling around bends are transmitted via the hanger brackets and gusset plates into the crossmember. This must be dimensioned accordingly. It has to be ensured that the correct connection to the longbeam is used. The connection of rigid-torsion, closed crossmember profiles to the soft-torsion dual-T longbeam must be designed with extra care as there is a risk of cracking due to stiffness discontinuity.

2. Gusset plates

The lateral forces are transmitted via the gusset plates as tensile resp. compressive loads to the crossmember.

The gusset plate has to be connected at the inner side of the hanger bracket, behind the spring bolt, to optimally stiffen the hanger bracket, which is open at the rear. The gusset plate should reach 50 mm lower than the centre of the spring bolt.

It is recommended to attach the gusset plate to the frame in the centre to the spring bolt. The "Welding Zone" of the hanger bracket is to be used for this purpose.

3. Vertical profiles

Suitable vertical profiles and ribs must be planned to stiffen the vehicle frame.

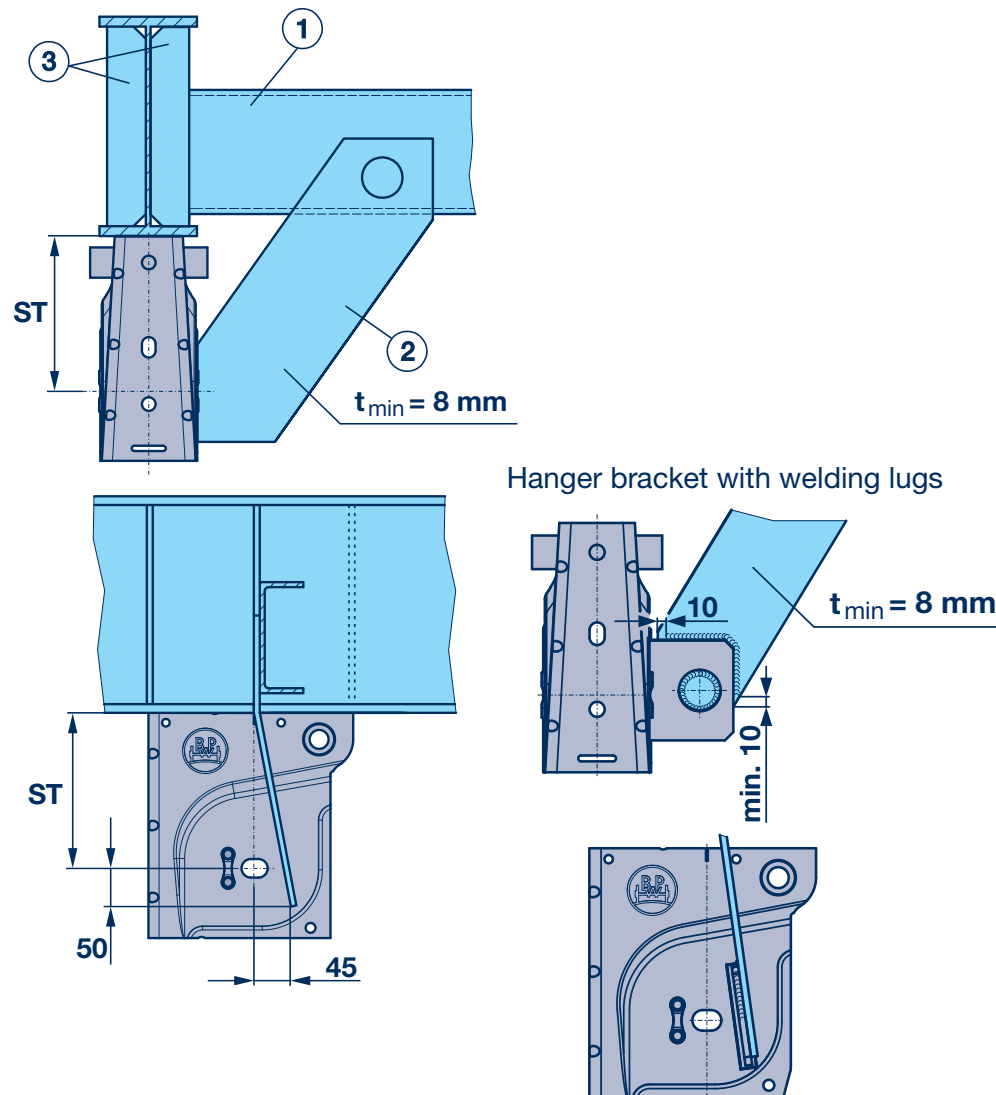

4.1.4 Hanger bracket brace | Welded gusset plates

Example of a general bracing proposal for in longitudinal direction torsionally stiff vehicles (tankers, silos)

The design example shown takes particular account of the space available for tanker or silo vehicles.

1. Crossmember

The forces created when travelling around bends are transmitted through the hanger brackets and gusset plates into the crossmembers. They must be dimensioned accordingly. It has to be ensured that the correct connection to the longbeam is used.

2. Gusset plates

The lateral forces are transmitted via the gusset plates as tensile resp. compressive loads to the crossmember.

The gusset plate has to be connected at the inner side of the hanger bracket, behind the spring bolt, to optimally stiffen the hanger bracket, which is open at the rear. The gusset plate should reach 50 mm lower than the centre of the spring bolt. The weld-on area extends upwards beyond the "Welding Zone" at the maximum. A second gusset plate provides the bracing between the vehicle frame side member and the crossmember.

3. Vertical profiles

Suitable vertical profiles and ribs must be planned to stiffen the vehicle frame.

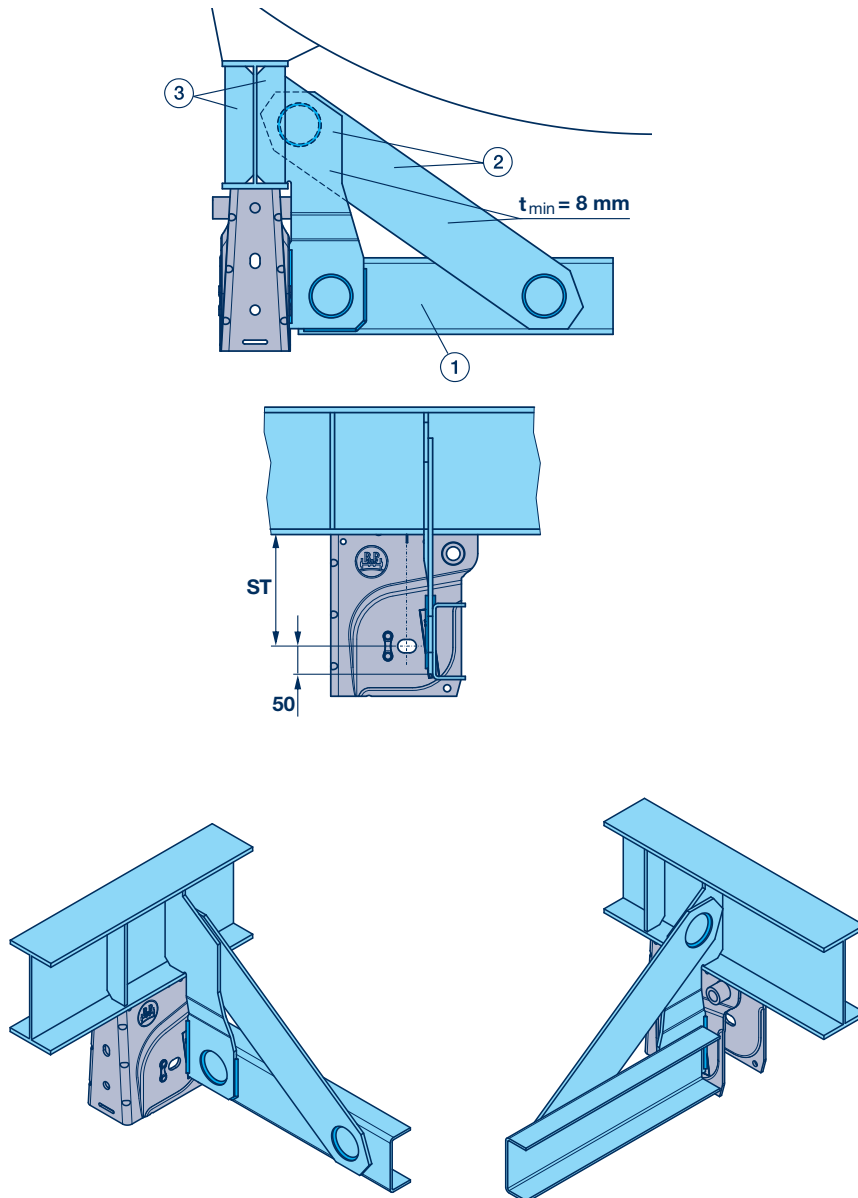

4.1.4 Hanger bracket brace | Bolted-on gusset plates

General

BPW offers the option of using bolted-on gusset plates with the flanged spring bolt 1a for the hanger bracket. The final design is only determined during the installation of the axle and suspension unit. The bolt-on system therefore provides vehicle manufacturers with logistics advantages and increases production flexibility.

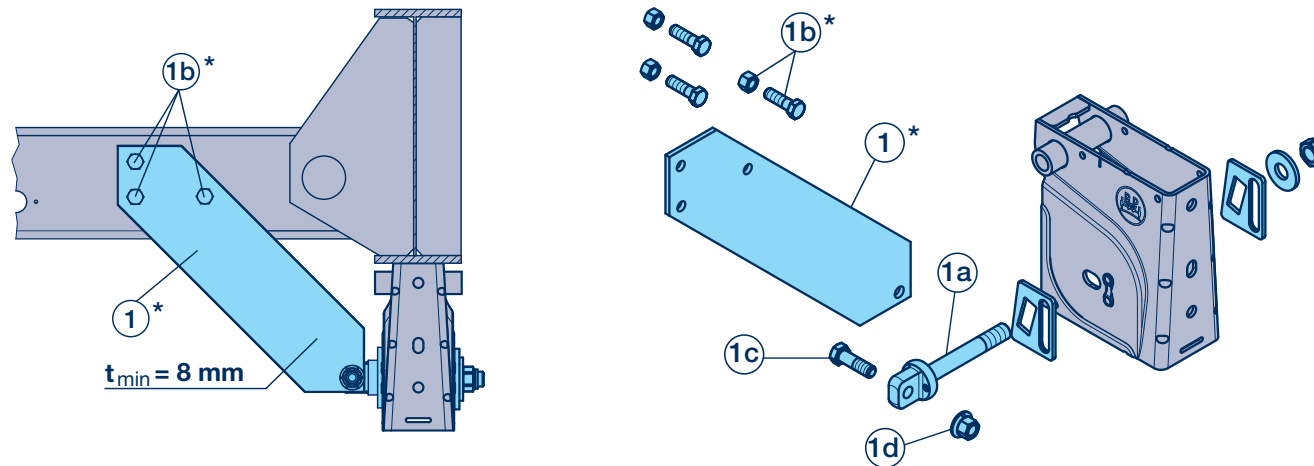

* Not included in BPW scope of delivery

! As the torsion protection of the screwed joint is created by the spring bolt flange, the bolt must always be attached to the vehicle frame through a gusset plate.

A bolt-on crossmember between the spring bolts is impermissible without a connection to the frame!

With vehicle frames that are subject to torsion, a corresponding elastic and torsional brace on the hanger brackets is particularly necessary.

4.1.4 Hanger bracket brace | Bolted-on gusset plates

Example of a general bracing proposal with bolted gusset plates

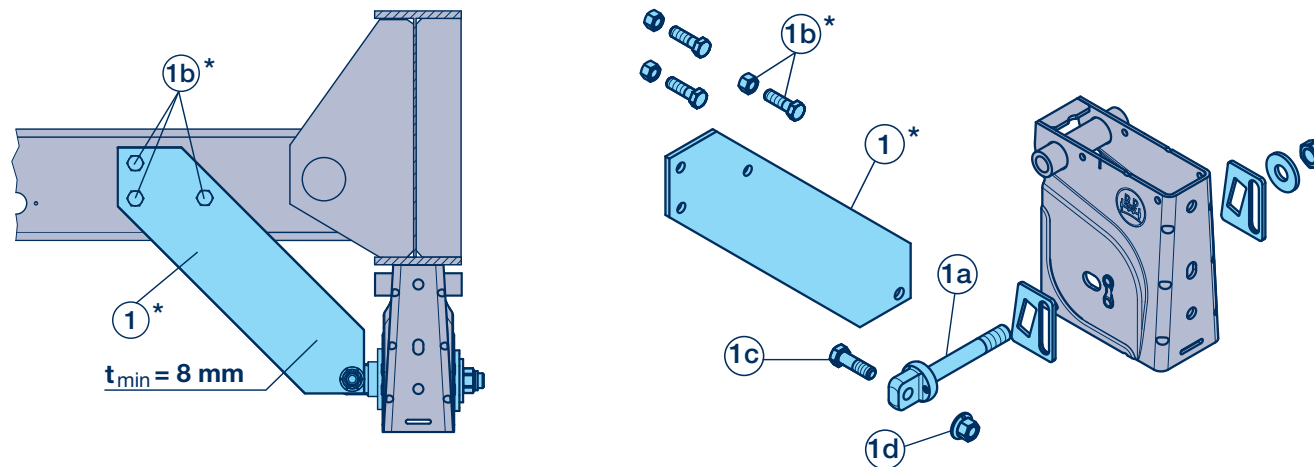

*Not included in BPW scope of delivery

The bore holes in the components must have the following diameters:

Bore hole in the crossmember: \varnothing 16 mm

Bore hole in the gusset plate: \varnothing 18 mm

Gusset plate screw connections

The bottom end of the gusset plate (1) is bolted onto the spring bolt (1a) directly using an M 18 connection bolt with nut (1c), (1d) which therefore permits direct force input.

The spring bolt itself is a special bolt with flange. The flange simultaneously serves as a torsion protection.

The top end of the gusset plate is bolted onto the crossmember of the frame using at least three M 16 10.9 bolts (1b).

Installation instructions for bolt-on gusset plates:

1. Loosely pre-mount spring bolt (1a).
2. Pre-mount the gusset plate (1) with at least three M 16 10.9 bolts (1b) (top) and a M 18 bolt (1c) (bottom).
Pre-mount the corresponding nuts.
3. Tighten the M 18 connecting bolt (1c) to approx. 50 Nm.
4. Tighten the M 24 spring bolt loosely until all components have been brought into contact.
5. Adjust track (see Alignment, [see chapter 4.1.8](#)).
6. Tighten M 24 spring bolt.
Tightening torque: 650 Nm (605 - 715 Nm)
7. Do not use an impact wrench!
8. Tighten the M 18 connecting bolt (1c).
Tightening torque: 420 Nm (390 - 460 Nm)
9. Tighten the top connecting bolts M 16, 10.9 (gusset plate / crossmember) (1b) to the max. permitted tightening torque (not supplied by BPW).

Tightening torques [see chapter 4.1.11](#).

4.1.5 Spring bolt bearing

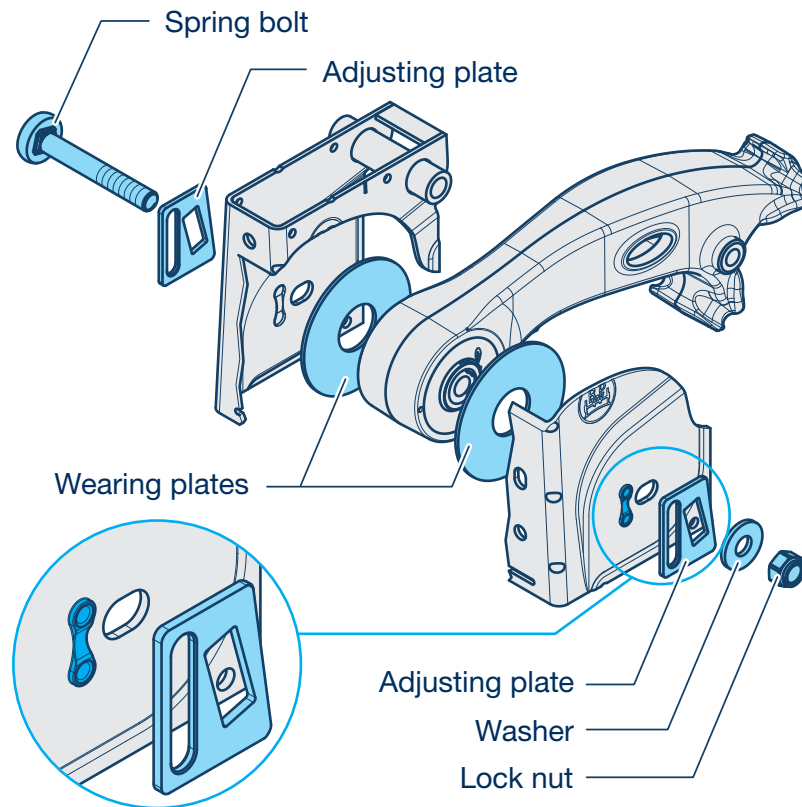

With ECO Air running gear systems, the head of the spring bolt is secured from rotating by means of a profiled lot in the adjusting plate.

The adjusting plates are secured, both against horizontal movement as well as rotation, by the guide elements press-formed into the hanger bracket.



Ensure that the adjusting plates are correctly seated on the guide elements (arrows) of the hanger brackets, mount both adjusting plates in the same direction.

The square shape on the spring bolt head (anti-rotation lock) must sit in the groove of the adjusting plate.

Before tightening the lock nut, the axle position must be set to ride height to prevent impermissible distortion of the rubber bush.

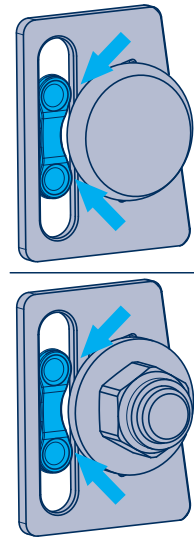

When mounting a single-sided axle lift [see chapter 4.1.10](#).

Tightening torques [see chapter 4.1.11](#)

4.1.6 Air bags | General

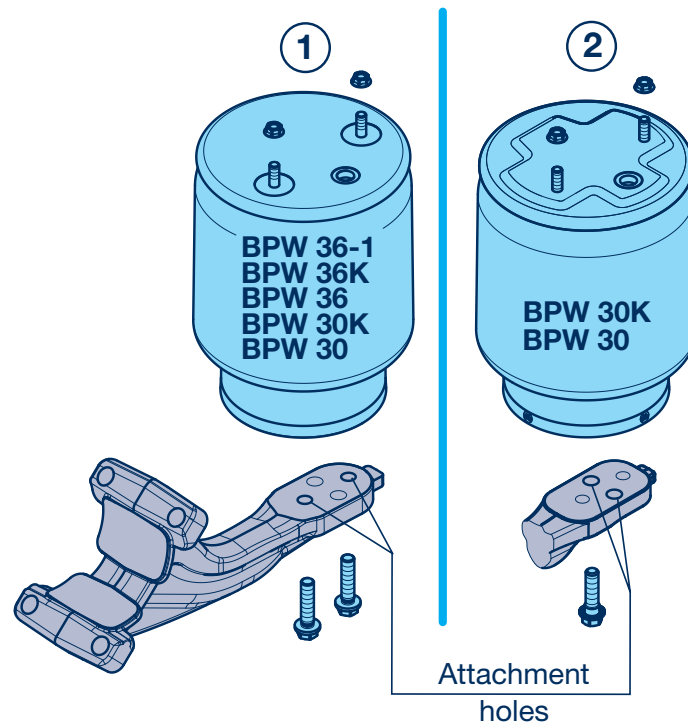

The top air bag plate is attached to the vehicle frame through the screwed joint of the 2 stud bolts (M 12).

Type 30 bags are operated at a higher pressure than type 36 bags. The quicker power build-up is achieved thanks to the lower pressure in the type 36 bags. They are therefore particularly suitable for applications where it is important to raise or lower the vehicle quickly. Type 36 bags also have a bigger power reserve for greater lifting heights.

4.1.6 Air bags | General

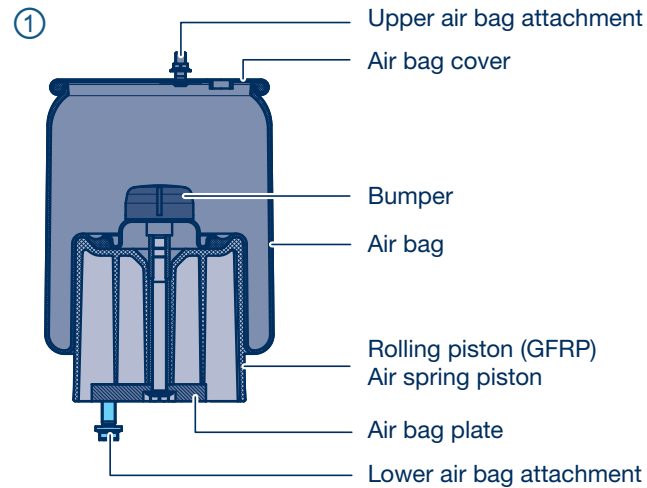

Two versions of air bags are used with ECO Air running gear systems.

① Air bags with bolted mounting plate or washer (BPW 36-1) in air spring piston.

The air bag is connected to the air bag support by **two** fastening screws.

The following offset dimensions are achieved by the mounting plate:

0 / 20 / 60 mm with air bag - \varnothing 300

45 / 80 mm with air bag - \varnothing 360

Special offset with air bag - \varnothing 360 = 0, 32, 55, 90

② Air bag with central bolt (\varnothing 300)

The air bag is connected with the air bag support with one fixing screw.

Offset dimensions of 20 mm are achieved through the holes in the air bag carrier.

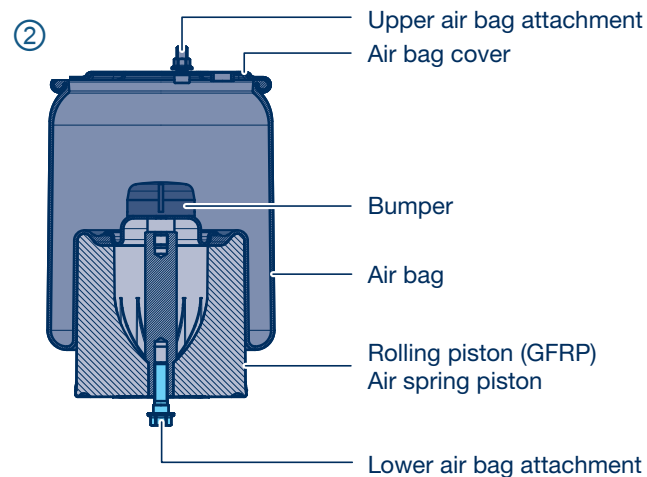

Tightening torques [see chapter 4.1.11](#).

4.1.6 Air bag | Versions

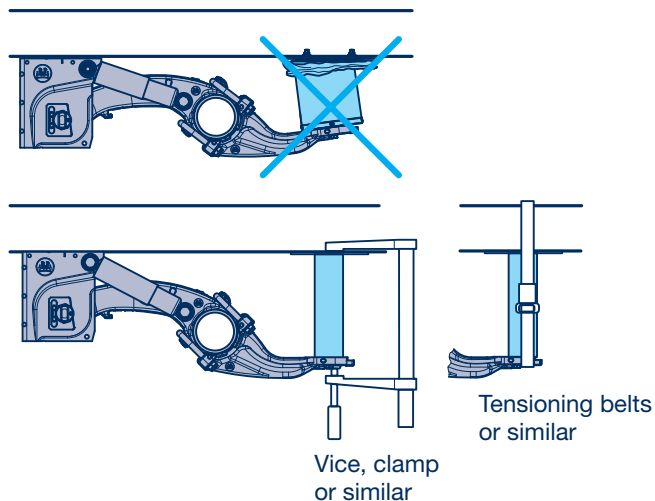
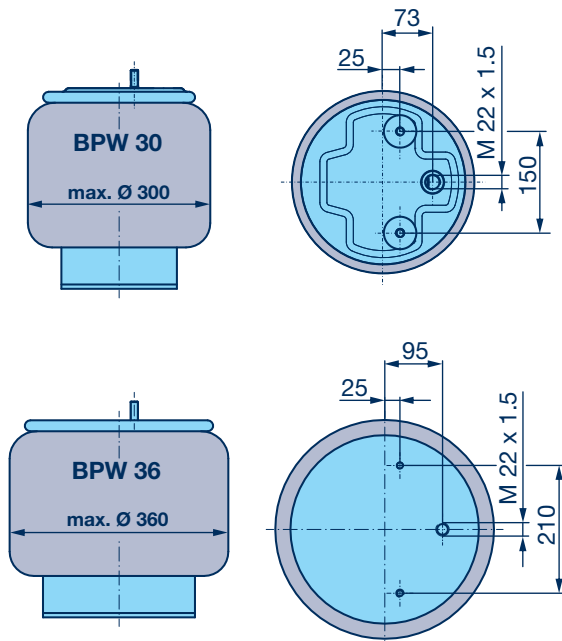

The various air bag lengths (K, Standard, -1) result in various spring deflections and lifting heights (e.g. 190 mm, 220 mm, 260 mm at axle centre). Greater spring deflections are generally more suitable for off-road use to ensure the required axle load equalization.

Air bag BPW 30

- BPW 30 for 220 mm spring deflection at axle centre
- BPW 30 K for 190 mm spring deflection at axle centre
- Diameter max. 300 mm at approx. 5 bar
- Specific air bag pressure 0.00023 bar/N (at ride height)
- Air bag offset $V = 0, 20, 60$ mm at air bag with bottom plate
- Air bag offset $V = 20$ mm with air bag with central bolt

Air bag BPW 36

- BPW 36 for 220 mm spring deflection at axle centre
- BPW 36 K for 190 mm spring deflection at axle centre
- BPW 36-1 for 260 mm spring deflection at axle centre
- Diameter max. 360 mm at approx. 3.5 bar
- Specific air bag pressure 0.000156 bar/N (at ride height)
- Air bag offset $V = 80$, bottom air bag plate with $t = 14$ mm
- Air bag offset $V = 45 / 80$ (0, 32, 55, 90), reinforced bottom air bag plate with $t = 20$



The rubber roll bag is a sensitive component and must be protected against damage during the vehicle production process, just like the tyres.

The air bag should always be installed with the rubber rolled up. The rubber must not crease as the folds leave a permanent mark and will influence the rolling behaviour and life expectancy at a later date.

If the semi-finished vehicle or chassis is moved on its own axle for purposes such as paint application, for instance, it is recommended to install a strut as an air bag replacement. By doing so, the air bag also does not have to be covered to protect it against the paint and is only installed during the final assembly stage.

4.1.6 Air bags | Air bag with offset

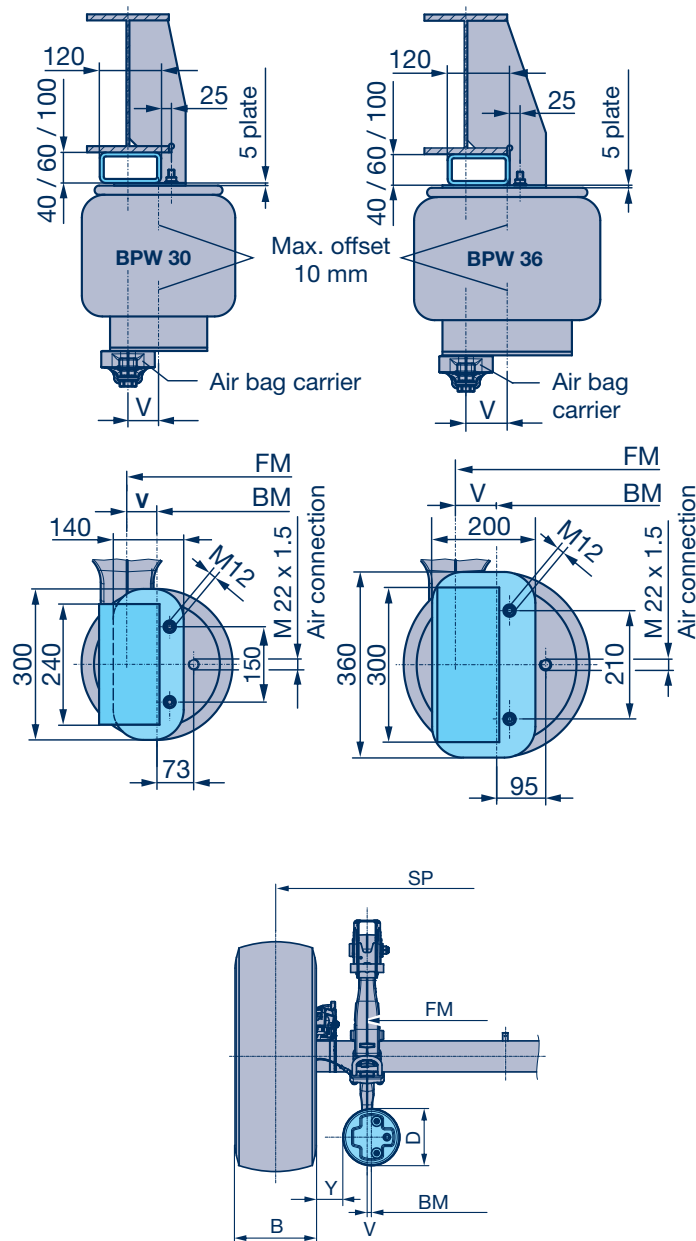

General

The transmission of force between the air bag and vehicle frame must be ensured with a suitable design. Particularly when installing components with an offset to the side, the bending moment which occurs must be absorbed with ribs and gusset plates or even crossmembers. The air bag force calculation is described in [chapter 4.1.2](#).

The "loaded without air" load case must also be taken into consideration. In special situations (e.g. loading a semi-trailer onto a ferry or unloading a rear tipper), the axle load portion which then must be supported through the air bag bumper can significantly exceed the static value.

During installation, the air bag centre at the top (on the vehicle frame) must not deviate by more than 10 mm from the air bag centre at the bottom (on the axle side). The air bag must not be installed with a twist between the top and bottom air bag attachment.

Example of installation and reinforcement with packer

In this case, an air bag plate with the following minimum dimensions must be planned in addition to the square tube and rib:

Air bag BPW 30: 300 mm x 140 mm

Air bag BPW 36: 360 mm x 200 mm

Example of installation and reinforcement without packer

In this case, the air bag plates also have to be planned with the minimum dimensions stated above.

Clearance between air bag and tyre

The min. clearance between the air bag and tyre should be at least 30 mm and can be calculated as follows:

$$y = 0.5 \times (SP - FM - B - D) + V$$

SP	= Track width
FM	= Spring centre
D	= Air bag diameter
V	= Air bag offset
B	= Tyre width
BM	= Air bag centre

Clearance between air bag and brake cylinder (for drum brakes)

The min. clearance between the air bag and brake cylinder must be 30 mm.

Tightening torques [see chapter 4.1.11](#).

4.1.6 Air bags | Air bag in centre of frame

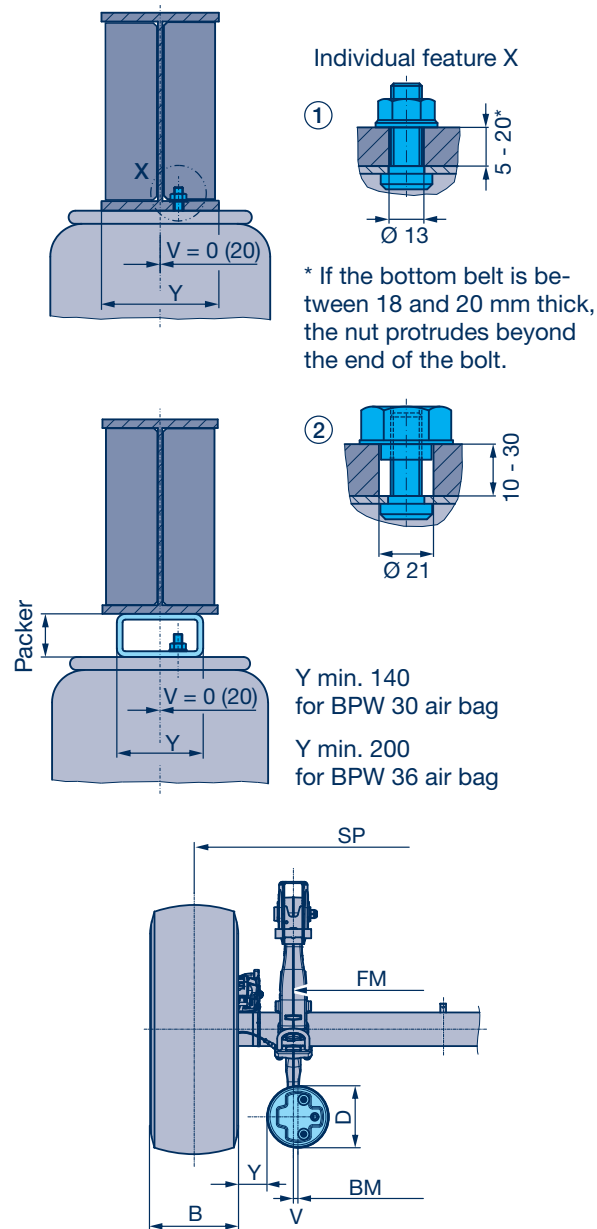

General

The transmission of force between the air bag and vehicle frame must be ensured with a suitable design. The air bag force calculation is described in Chapter 4.1.2. The "loaded without air" load case must also be taken into consideration.

In special situations (e.g. loading a semi-trailer onto a ferry or unloading a rear tipper), the axle load portion which then must be supported through the air bag buffer can significantly exceed the static value.

During installation, the air bag centre at the top (on the vehicle frame) must not deviate by more than 10 mm from the air bag centre at the bottom (on the axle side). The air bag must not be installed with a twist between the top and bottom air bag attachment.

Example of installation and reinforcement without packer

When installing the air bag in the centre of the frame with little or no offset ($V = 0$ or 20 mm), holes may be drilled into the bottom flange of the vehicle frame for inserting the bolt M 12. For bottom flanges with a thickness of 20 mm, shaft nuts with spring washers must be used, and bore holes with 21 mm diameter.

Example of installation and reinforcement with packer

The minimum dimensions of the air bag support (plate or wide flange) for the BPW 30 air bag must also be 140 mm x 300 mm in this case.

Clearance between air bag and tyre

The min. clearance between the air bag and tyre should be at least 30 mm and can be calculated as follows:

$$y = 0.5 \times (SP - FM - B - D) + V$$

SP	=	Track width
FM	=	Spring centre
D	=	Air bag diameter
V	=	Air bag offset
B	=	Tyre width
BM	=	Air bag centre

Clearance between air bag and brake cylinder (for drum brakes)

The min. clearance between the air bag and brake cylinder must be 30 mm.

Tightening torques [see chapter 4.1.11](#).

4.1.6 Air bag | Air bag with split piston

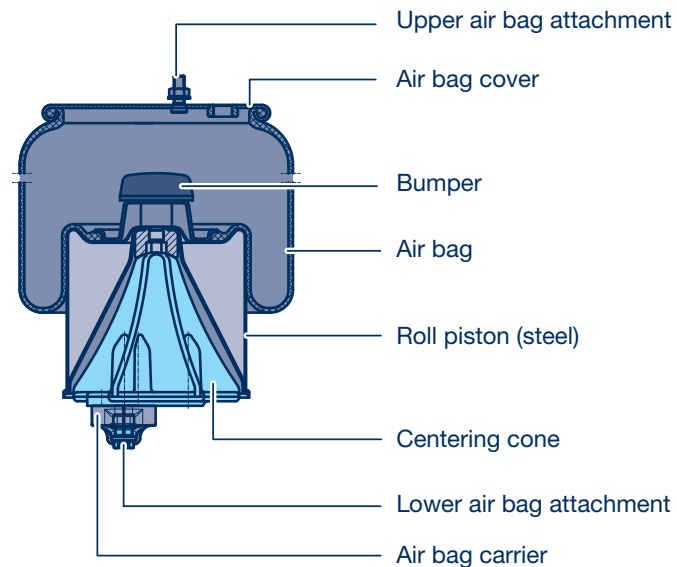

This design (Kombi-Airbag) provides unrestricted usability of vehicles with air suspension for intermodal transport.

The air bag is split in two halves and consists of the central cone which is installed on the air bag carrier and the air bag with the piston.

If the vehicle is raised after de-aeration, the axles move downwards through their own weight. The air bag with the piston remains in its resting position and the air bag carrier with the central cone drops down.

The air suspension unit securely reconnects once the vehicle is lowered again. The air bags can neither fold nor crease.

This guarantees a long life expectancy.

When driving on road, there is no difference between the split piston and a conventional BPW air suspension.

Split air bags are available as BPW 30 or BPW 30K.

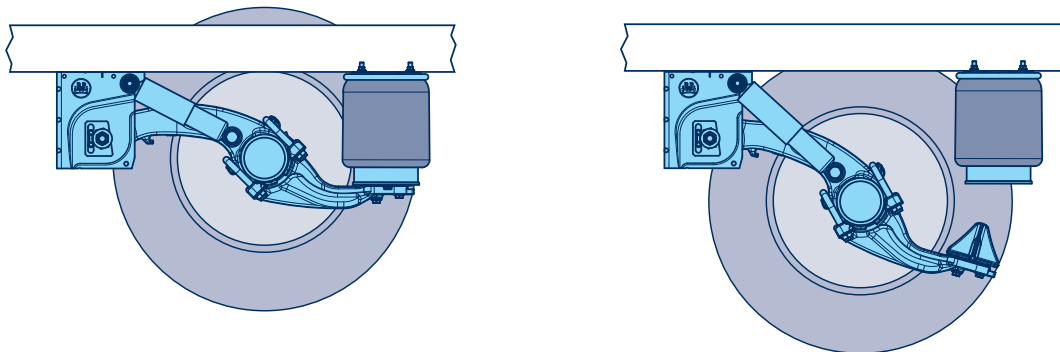

As the shock absorbers act as end stops in this configuration, it must be ensured that they are installed with a corresponding length.

Please refer to the instructions on the air suspension installation / raising and lowering ([see chapter 4.1.9](#)).

The corresponding series designs are listed in the EA data sheets (My BPW).

4.1.7 Shock absorber

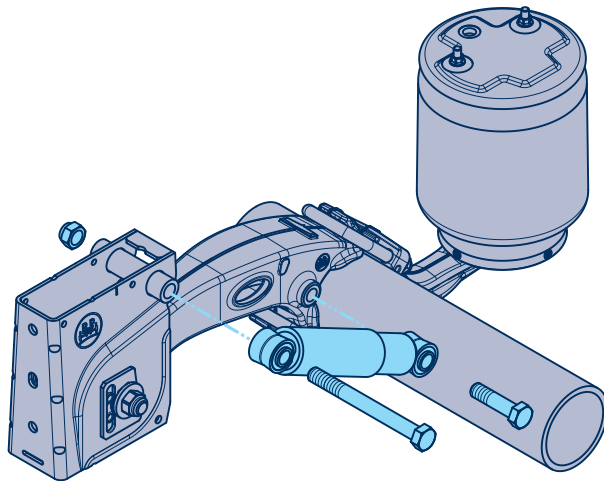

Shock absorber lever

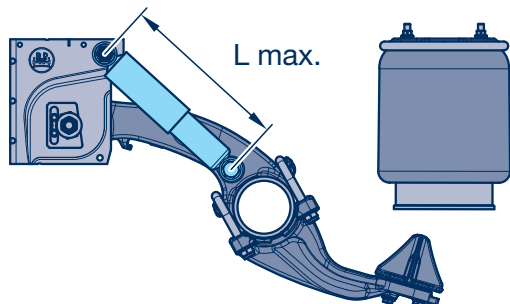
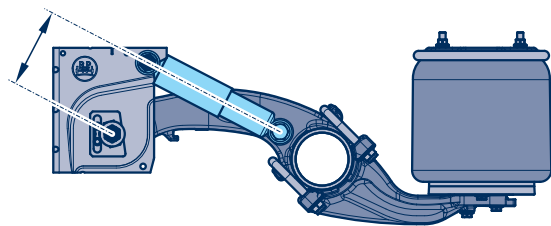

The purpose of shock absorbers is to rapidly reduce the vibrations occurring between the axle and body during driving.

This prevents any further yawing of the body and running gear components, and ensures that the tyres maintain optimum roadholding. The purpose of this roadholding is to ensure that the vehicle tracking remains accurate and that the vehicle brakes correctly.

BPW shock absorbers operate according to the twin tube principle. In the compression stage (corresponding to upward travel), the oil is pressed into the working space at the top, which then flows back into the working space at the bottom during the rebound travel (corresponding to downwards travel). The built-in valves produce the required damping characteristics (characteristics curve).

The effect depends on this characteristics curve as well as the lever around the spring bolt. The damping torque crucial for the dampening process results from the damping force and this lever.

BPW shock absorbers are matched to the vehicle, overall height, installation position and applications.

BPW recommends using HD shock absorbers for use on rough road surfaces and for high off-road speeds.

For air suspension systems with split pistons, the shock absorbers are provided with an end stop to prevent further lowering of the axles.

Shock absorber attachments

The shock absorbers are located on the side next to the hanger brackets with ECO Air running gear systems.

The upper attachment of the shock absorbers is secured using hexagon bolts with lock nuts.

In the case of the lower attachment, the shock absorber is connected to the trailing arm by means of a hexagon bolt. If this connection is loosened (replacement of the shock absorber or other), use a new hexagon bolt or liquid screw locking.

Tightening torques *see chapter 4.1.11.*

4.1.7 Shock absorber

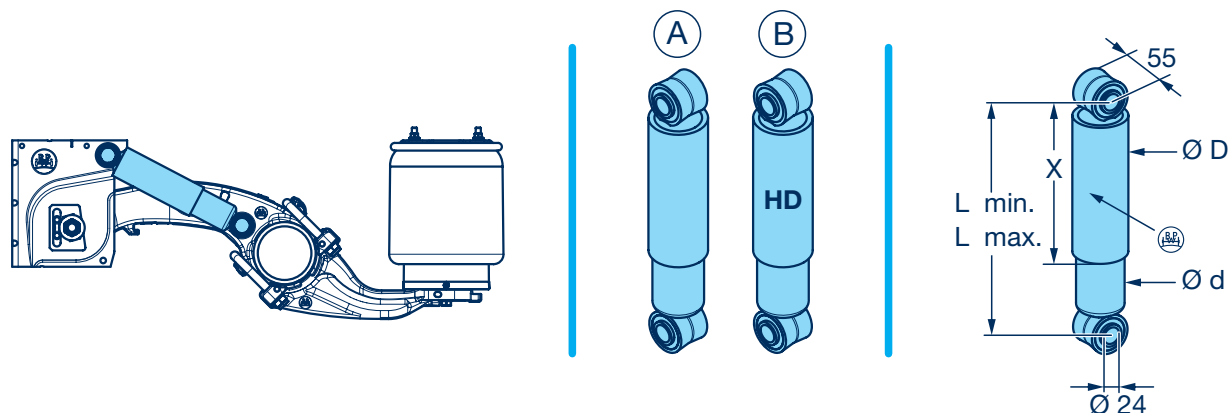

BPW item number	Exec.	Dimension					N = Newton at 13 cm/s	N = Newton at 52 cm/s
		L min.	L max.	X	D	d	↕ N / ↕ N	↕ N / ↕ N
02.3722.79.02	A	287	412	204	75	65	13280 / 2930	15250 / 5010
02.3732.05.02	B			195	74		6300 / 1740	17000 / 3000
02.3722.89.02	A	292	432	204	75	65	13280 / 2930	15250 / 5010
02.3732.07.02	B			195	74		6300 / 1740	17000 / 3000
02.3722.04.02	B			255	74		6300 / 1740	17000 / 3000
02.3722.83.02	A	326	496	235	75	65	13280 / 2930	15250 / 5010
02.3722.88.02	A	351	541	250	75	65	13280 / 2930	15250 / 5010
02.3732.06.02	B			255	74		6300 / 1740	17000 / 3000

In individual cases, it may make sense to mount the damper at a different point in the chassis rather than on the hanger bracket.
 Recommendation for dimensioning brackets for installation position I (front-mounted dampers): Rebound 31 kN, Compression 11.5 kN.

4.1.8 Alignment | Conventional axle alignment

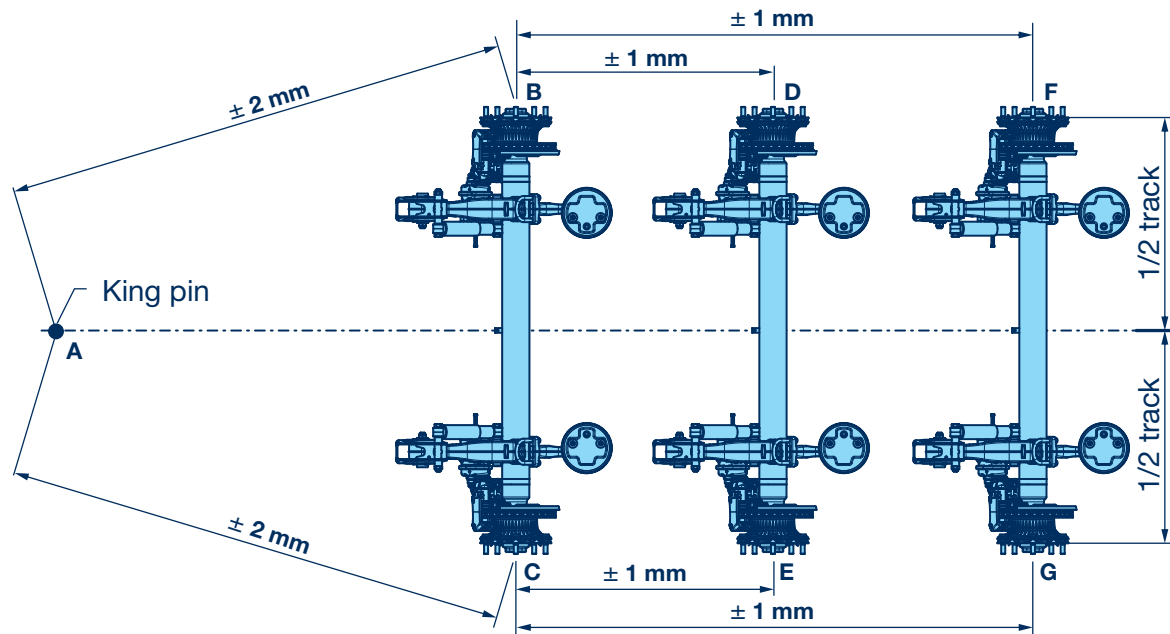

To compensate for manufacturing tolerances, an axle alignment check must be conducted and any corrections made as necessary.

Determine the diagonal dimensions **A - B** and **A - C** for the front axle (reference axle) by means of comparative measurements ($\pm 2 \text{ mm}$ tolerance). Check and if necessary correct the wheelbase dimensions **B - D** and **C - E** for the mid-axle, and **B - F** and **C - G** for the rear axle (max. tolerance 1 mm). Measurement is generally carried out by the hub cap centre point (illustration on the right). It can also be carried out using suit-

able distancing devices or screwed-on calibration tubes.

Care must be taken to ensure that the axle is aligned horizontally (at ride height) in order to obtain a correct measurement.

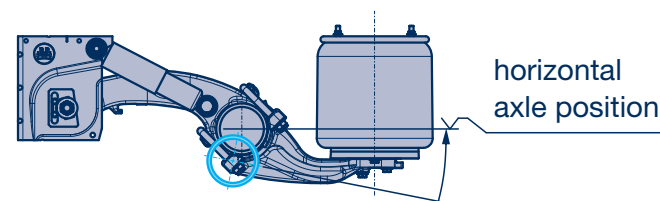

The triangle in the BPW logo is in the centre and can be used for holding a measuring tool:

The maximum possible wheel base correction per axle for adjustable hanger brackets (see page no. 161) is $\pm 5 \text{ mm}$.

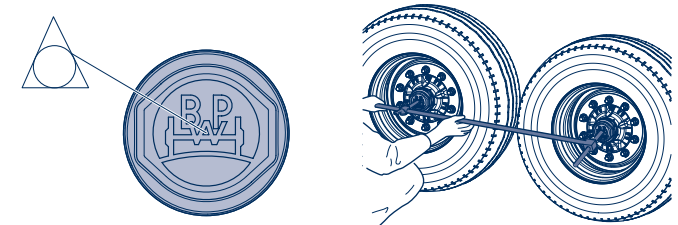

This method only takes into consideration the axle distances but not the individual track values on the axle sides. This is sufficient for axles with optimal track values. This conventional method has a higher probability of incorrect measurements than the laser method (see page no. 160). The measurement of smaller differences across greater lengths can be impacted by factors such as the elasticity in the measuring tool (manual force).

4.1.8 Alignment | Axle alignment with laser measuring system

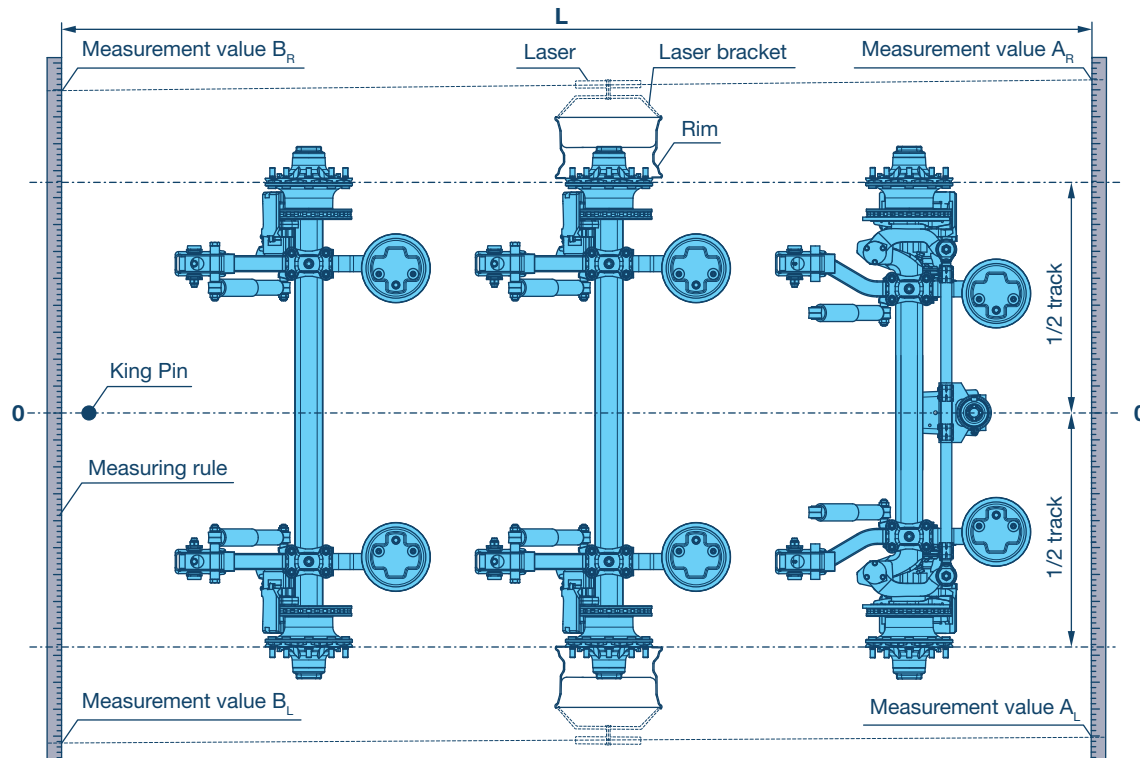

To compensate for manufacturing tolerances, an axle alignment must be conducted and any corrections made as necessary.

Care must be taken to ensure that the axle is aligned **horizontally** (at ride height) in order to obtain a correct measurement. It is assumed to refer to an unladen vehicle.

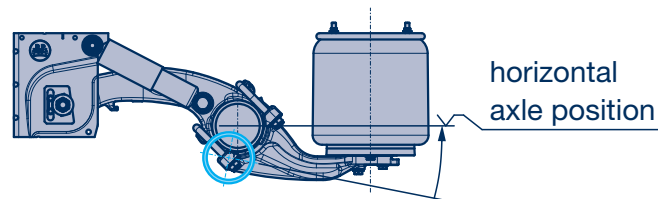

The maximum possible wheelbase correction per axle with adjustable hanger brackets (see [page no. 161](#)) is ± 5 mm.

During the tracking process, the tracking values of the right and left wheel side must be averaged for each axle.

Instead of measuring all three axles using the laser method, it is also possible to only track the mid-axle using the laser method. The front and rear axle are positioned relatively to the mid-axle using suitable axle centre distance devices (like during conventional tracking).

$$\frac{(A_R - B_R) + (A_L - B_L)}{L} = \text{Axle track (mm/m)}$$

Positive value = toe-in

Negative value = toe-out

Target values (total axle track):

-2 ... + 5 mm/m (round tube axles 146 mm)

4.1.8 Alignment | Axle alignment check for axles with adjustable hanger brackets

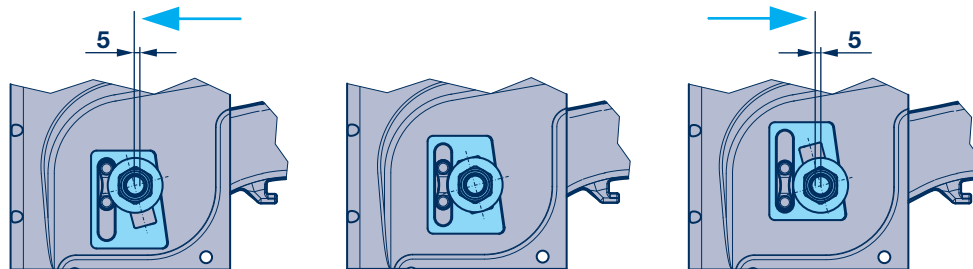
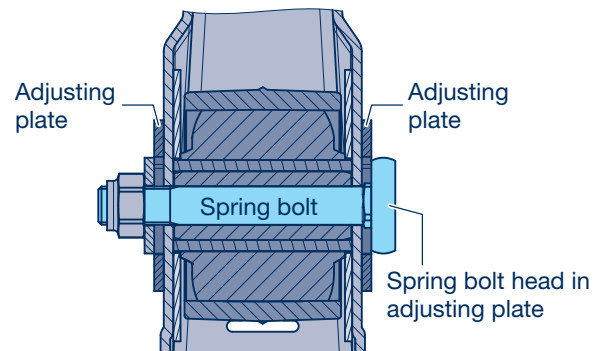

General

It is necessary to check the axle alignment during installation as well as after repairs on axles, hanger brackets or trailing arms. The measurement of diagonal dimensions and wheelbases is carried out as described on pages 159/160.

If a track correction is necessary, it can be carried out as follows:

Axle alignment correction

1. Raise and support the vehicle frame at ride height.
2. Deflate air bags.
3. Slacken the lock nuts on the spring bolt.
4. Align the front axle (reference axle). To do so, slide the adjusting plates upwards or downwards with light hammer blows (see fig. below).
5. Make sure that the inner and outer adjusting plates on each hanger bracket are adjusted symmetrically.
6. Tighten lock nut on the spring bolt to the specified tightening torque.
7. Check the correct axle alignment of the front and rear axles and realign if necessary
8. Inflate the air bags and remove supports from underneath the vehicle.

Tightening torques *see chapter 4.1.11.*

 The spring U-bolts must not be loosened on adjustable hanger brackets.

4.1.9 Air suspension installation | General

The BPW air suspension kit is only as good as its installation. If installed incorrectly, the BPW warranty becomes null and void.

The air suspension is supplied with compressed air from the brake system via a pressure limit valve.

The air tank pressure is approx. 6.5 bar. An air supply of 20 litres is recommended for each axle, raising and lowering demands correspondingly more.

Without an appropriate air supply there is a risk for safety as no air will remain for the air suspension if the wheel brake has a high air consumption.



To achieve good axle load equalization, the piping connecting the air bags should not have an inner diameter of less than $\varnothing 8$ mm (e.g. $\varnothing 10 \times 1$).

On request, BPW also supplies installation parts and plans for common air suspension installations. The installation plans identify the valves using the ISO illustration method.

Example for air suspension installation:

Tri-axle suspension, raising and lowering, with two-sided axle lift

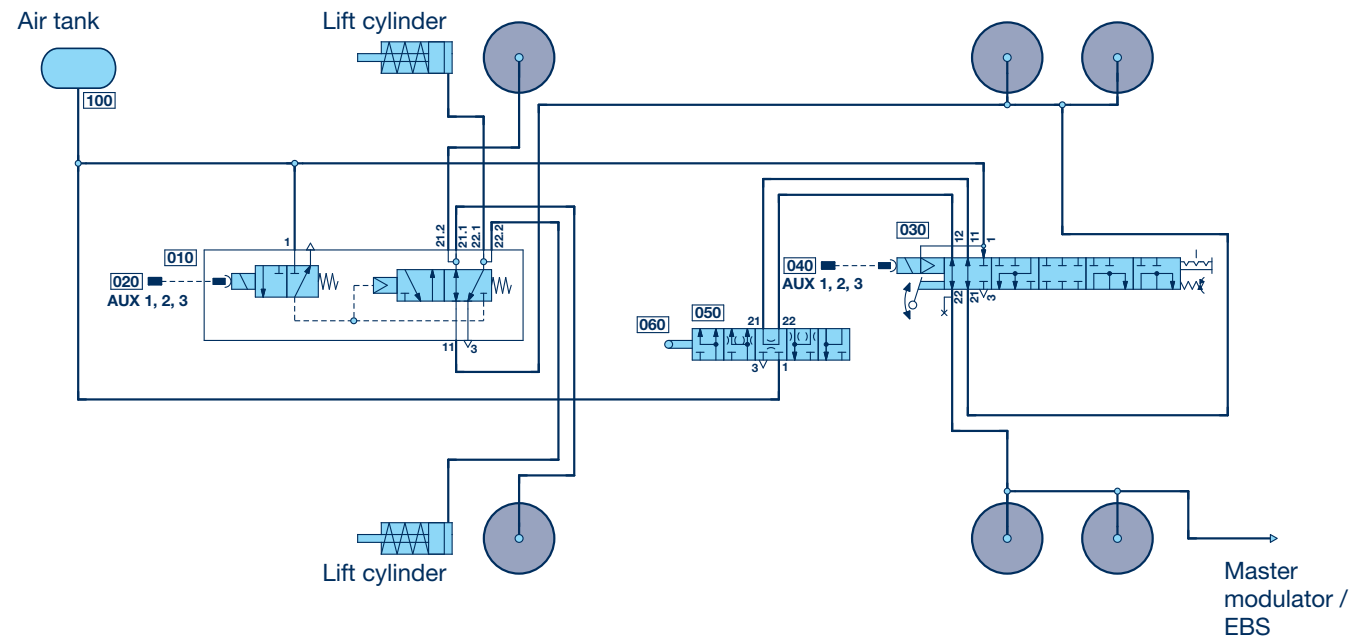

- 010 Lift axle valve
- 020 Connection cable EBS
- 030 Lift and sink valve
- 040 Connection cable EBS
- 050 Air suspension valve
- 060 Connection to the axle beam (see page no. 164)
- 100 Air tank

4.1.9 Air suspension installation | Single and dual-circuit air suspension installation

BPW air suspension kits feature a high roll stability for low side tilt when cornering, leading to excellent road safety. This high roll stability is achieved by supporting the superstructure especially with the trailing arm / axle beam / trailing arm unit when cornering.

The support from the air bags also has an impact, albeit a much smaller one.

For dual-circuit air installation kits, the air bags on the right and left sides of the vehicle are pneumatically separated and are only connected together by a transverse throttle in the air suspension valve. This ensures that the air pressure can compensate slowly when cornering. This creates an additional stabilizing effect when cornering quickly in different directions.

Single-circuit air installation kits (e.g. through a distributor block) do not have this stabilising effect.

Due to the long-standing experience of using single-circuit air installations gathered as well by now, these single-circuit systems can also be approved without reservations for standard applications.

4.1.9 Air suspension installation | Air suspension valve / height sensor

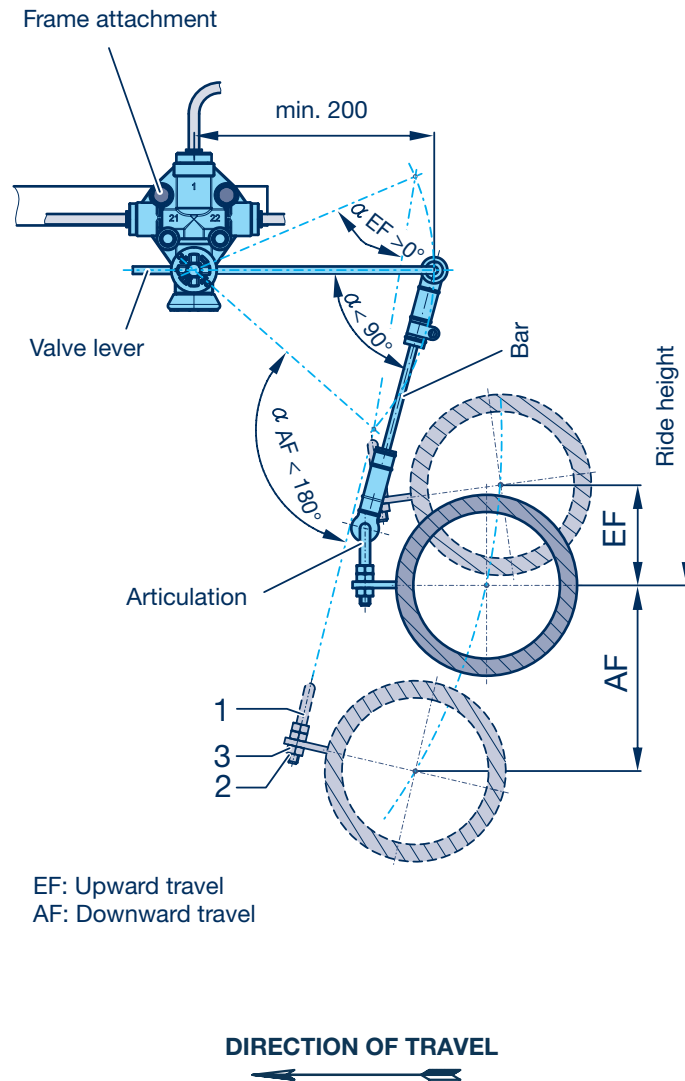

General

BPW air suspension axles are prepared as standard with a support for an air suspension valve.

This regulates the air bag pressure according to the respective vehicle load, thereby holding the vehicle at a constant ride height. The air suspension valve is screwed to the vehicle frame and connected to the axle via the lever and bar. The pivot link is located in the middle of the axle, on tri-axle suspensions at the mid-axle, on two-axle suspensions on the rear axle. In special cases (e.g. axle lift device, large vehicle slope) the air suspension valve may also be connected to the front or rear axle.

The valve lever, which is at least 200 mm long, is positioned horizontally in the direction of travel. For testing purposes, the lever is pressed slightly downwards. The air must be released into the atmosphere via the pressure relieve valve.

If the air is directed into the air bag, the valve shaft must be rotated by 180° .

The valve lever must be switched over for this purpose. The ride height is set by adjusting the link rod in the rubber joints and then fixing this position with the lock nuts.

The vehicle must be standing on a level ground when this setting is made. The setting can be performed when the vehicle is laden or unladen. Electronic ride height measuring devices can also be installed.

Stroke limitation of air suspension axles for vehicles with a raising and lowering feature to adjust to the height of ramps can also be achieved with an air suspension valve with integrated shut-off, [see page no. 166](#).

4.1.9 Air suspension installation | Air suspension valve / height sensor

Body inclination

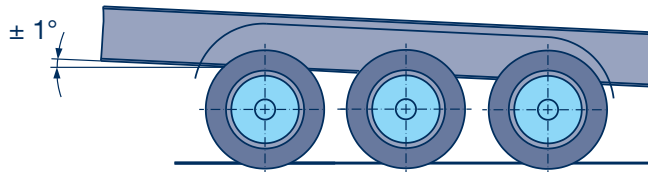

The max. body inclination of the semi-trailer must not exceed $\pm 1^\circ$.

Ride heights

The ride height of the air suspension axles should be set to the permitted range indicated according to the corresponding documents (data sheets).

With single axles a minimum upward travel of 60 mm is necessary. With multi-axle units a minimum upward travel of 70 mm is necessary.



The air suspension can be checked by activating the compression stroke to the air bag bump stop, and then the extension stroke to its limits (shock absorber, air bag length).

The angles stated must be maintained to avoid the valve linkage going over centre.

Due to the strong stabilizing effect, the use of two air suspension valves for regulating the sides is not recommended.

4.1.9 Air suspension installation | Air suspension valve / height sensor

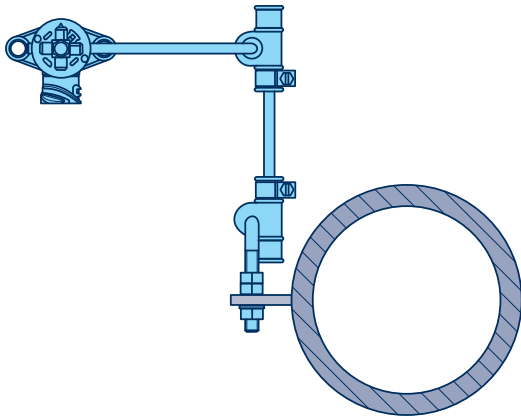

In addition to conventional air suspension valves operated by lever mechanisms, electronic air suspension modules are often found in vehicles on the market. The conventional air suspension valve is replaced with a robust ride height sensor and a multifunctional air suspension block is added.

The sensor is usually connected to the brake system, which also controls the valve functions.

The ride height is regulated in a closed regulation circuit, which has advantages compared with a conventional air suspension system when regulating ride heights in terms of parameters and diagnostics options for the vehicle manufacturer and driver.

The mechatronic ride height adjuster also provides further advantages compared with conventional valve technology:

- Low air consumption as the level regulation is not linked to the dynamic upward / downward movements
- Easy option for realising several ride heights
- Integrated shut-off
- Reset-to-ride function without additional valve technology
- Rapid raising and lowering due to large valve cross-sections
- Lift axle control with residual pressure tank, often integrated in the valve block for traction assists and manoeuvring aids
- Operability of the trailer suspension from the truck or via mobile devices
- Installation advantages due to reduced wiring and piping

4.1.9 Air suspension installation | Raising and lowering

Today, lift and sink valves, often also called rotary disc valves, provide further functionalities and switchings for influencing the ride height in addition to the original function of raising or lowering the ride height of a vehicle. Depending on the air suspension valve installed, lift and sink valves can be designed as single or dual circuits. The lift and sink valve is switched behind the air suspension valve and connects the air bags of the axle with the air suspension valve.

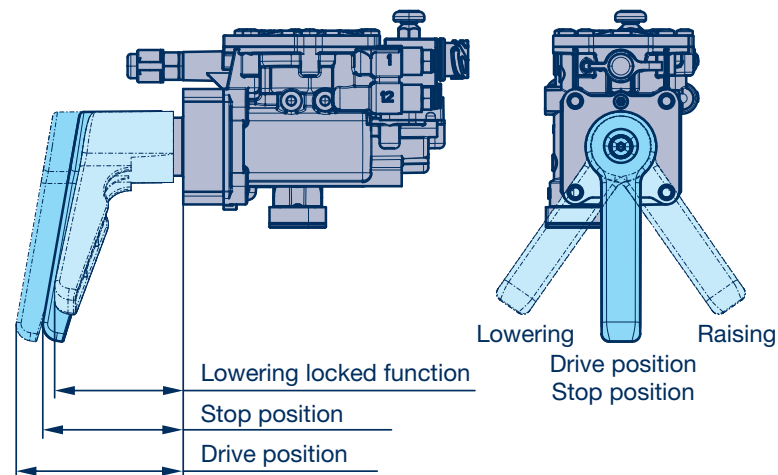
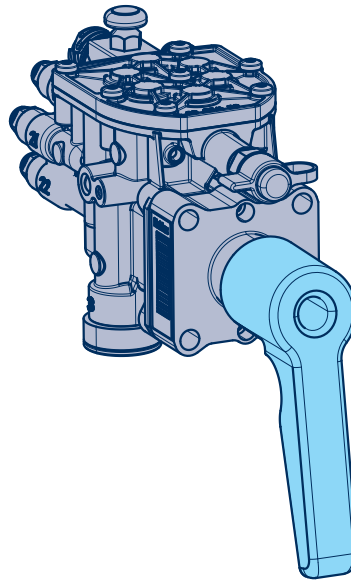

Ride height function

The ride height is usually secured through the air suspension valve, which inflates and deflates the air bags, depending on the ride height, thus keeping it constant. The connection of the air bags of the axles with the air suspension valve is also maintained.

Stop function

In this switching position, the link between the air suspension valve and air bags is interrupted and the last ride height set with the lift and sink valve remains intact. Changes to the ride height caused by loading or unloading are not compensated.

Raising function

To raise the ride height, the connection of the air bags with the air suspension valve is interrupted with the lift and sink valve and the air bags are inflated with supply pressure for raising the vehicle.

Lowering function

To lower the ride height, the connection of the air bags with the air suspension valve is interrupted with the lift and sink valve and the air bags are deflated for lowering.

4.1.9 Air suspension installation | Raising and lowering

Dead man's switch

The so-called dead man's switch ensures that the vehicle is only raised or lowered if the operator holds the operating lever in the corresponding raising or lowering position. Once the lever is released, it automatically returns to the stop position. This prevents the uncontrolled raising and lowering of the vehicle superstructure.

Lowering locked function

To load or fix vehicles in combination traffic, it may be necessary to lower the vehicle right down to the air bag stop and to maintain this condition for the duration of the vehicle transport. This function is often also called ro-ro function (roll on / roll off).

Resetting the vehicle to ride height

The vehicle is primarily reset to ride height, often also called reset-to-ride function, through a switching impulse of the brake system. The ABS / EBS switching impulse is triggered once a certain speed is exceeded (e.g. 15 km/h) and operates a magnetic valve integrated in the lift and sink valve. This magnetic valve returns the

operating lever to the driving position and therefore ensures that the air bags are reconnected to the air suspension valve for the journey.

Stroke limitation – upward travel

The upward travel is limited by a rubber bump stop inside the air bag. The downward travel must be restricted under certain operating conditions.

Air bag type 30, 30 K, 36 or 36 K

As a rule, no stroke limitation is required for type 30, 30K, 36 or 36K air bags when a rotary disc valve with dead man's lever is installed.

Air bag type 36-1

Stroke limitation is required in vehicles with a raising and lowering device and type 36-1 / 36-2 / 36-5 air bags.

Stroke limitation designs – downward travel

The stroke limitation can be carried out via an air suspension valve with integrated shut-off (*see page no. 166*) or a separate shut-off valve. The shut-off valve is bolted to the vehicle frame and connected to the axle with a return spring attached to the tension pin. After the maximum lift height is reached, the air supply to the air bag is shut off and the stroke thus limited.

The limitation of raising and lowering devices without stroke limitation in the form of shut-off valves depends on the shock absorbers or air bag, depending on design. The shock absorbers are equipped with a travel limiter; however they are not designed to operate with airbag pressures above approx. 8.5 bar.

Rapid unloading

With vehicles where the payload is unloaded quickly, e.g. tippers, container vehicles, coil vehicles etc., stroke limitation is required by means of rapid venting of the air bags.

4.1.9 Air suspension installation | Raising and lowering

Crane, railway or ship loading

With vehicles for crane, railway or ship loading, BPW recommends split air bag pistons (Kombi Airbag system). If not expressly demanded in the technical documentation, no stroke limitation is needed when the split air bag is used. In this case, the shock absorber is the lower stop. Vehicles with split air bag must not be moved in the unvented condition when manoeuvring in Ferry and rail traffic.

Traction assist

Even if the vehicle is fully loaded, the semi-trailer front axle can be raised to increase the traction of the driven axle, e.g. in wintery conditions. In accordance with 97/27/EC, Section 3.5 of Annex IV, the deflation of the front axle of the suspension unit of the tri-axle semi-trailer correspondingly increases the load of the axles remaining on the ground. The load on these two axles may then be increased by 30%, corresponding to the following value:

18,000 kg plus 30% = 23,400 kg (11,700 kg per axle).

The air bag pressure of the axles on the ground also increases significantly, e.g. when using the 30 air bag (L1 = 500 mm and L2 = 380 mm), from 4.7 bar to 6.65 bar. It must be ensured that the reserve pressure in the tank is approx. 1.5 bar higher. This can prevent the temporary drop down to the bumper of the air bag and therefore an additional, impermissible load increase.

The above axle load increase is only acceptable under the conditions stated in the above guideline. After moving off, the load must automatically rest back on the lifted axle before exceeding 30 km/h.

4.1.10 Axle lifts; VECTO Bonus

BPW air suspension axles can be equipped with axle lift devices. With tandem suspensions, one axle can be raised,

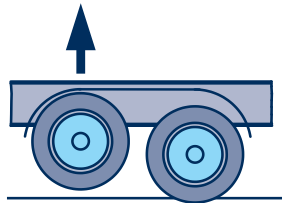

or max. two axles with tri-axle suspensions.

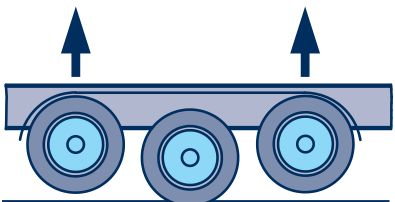
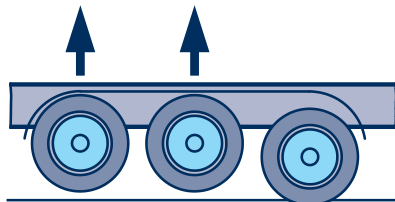

It is recommended to raise the front axle of a suspension due to the improved ground clearance (gradient of superstructure) and the longer wheel base, thus resulting in more stable driving characteristics.

In the case of vehicles with axle lift devices, ground clearance for the raised axle must be ensured.

The statutory provisions regarding turning circle requirement must be observed!

Control

Axle lift devices operate either EBS-controlled, electro-pneumatically (electric switch) or hand-pneumatically (manual valve) or automatically (compact valve).

An overload protection device, which is a legal requirement, is included in the BPW installation kit.

In the EBS version, the lift axes can only be controlled via EBS.

Optionally for ABS or conventional brake systems, the correct function of the ALB must be maintained!



Lift axles reduce rolling resistance and tyre wear. In the VECTO calculation (for O3 and O4 trailers or semitrailers with closed, box-shaped bodies), vehicles with lift axles therefore receive a bonus. For example, 0.4 % fuel consumption is accounted for in the case of three-axle trailers in long-haul transport, 3 % in regional transport, and 4.4 % in urban transport.



BPW air suspension kits and axle lift devices only operate as well as the installation of the air suspension: The reliable functioning of the axle lift and the correct rolling of the air bags should be ensured by means of the air installation and its activation times.

If installed incorrectly, the BPW warranty becomes null and void.

4.1.10 Axle lifts | Overview of designs

Double-sided axle lift

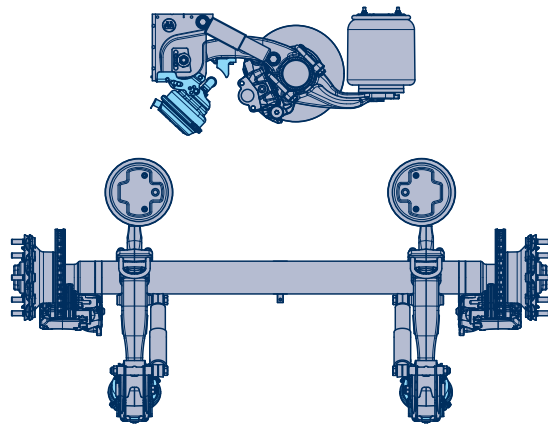

Can be used on all axles except long-stroke air bags. Installation space in front of the hanger brackets and in the centre of the vehicle remains free.

Side axle lift

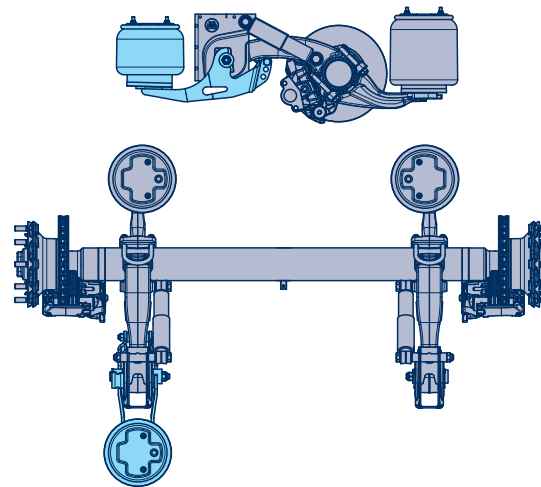

For raising the front axle

Central axle lift

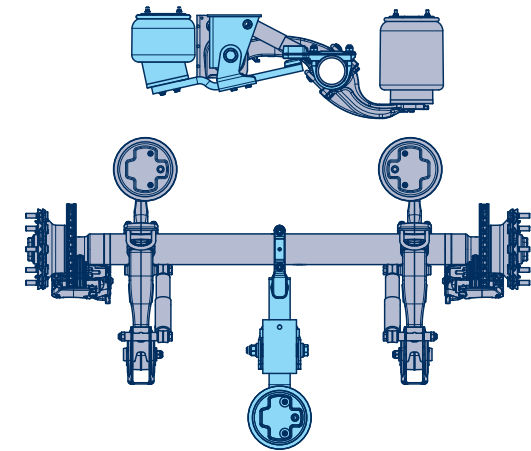

For raising the front, central or rear axle

4.1.10 Axle lifts | Lift stroke

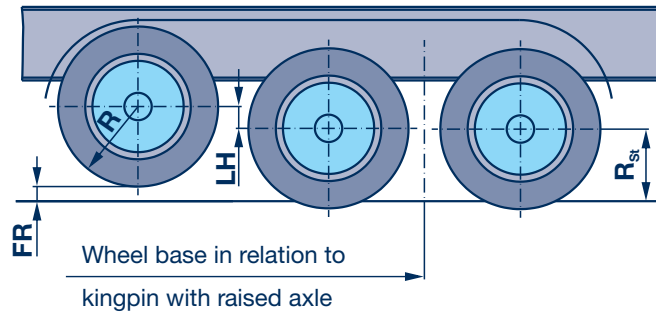

The ride height of air suspension units equipped with an axle lift device should be set at a minimum of approx. 100 mm upward travel to create sufficient ground clearance beneath the raised axle.

If it is impossible to adjust the ride height to the minimum upward travel, corresponding air suspension valve technology must be used to create sufficient ground clearance with a second ride height.

The axle lift stroke equals the suspension upward travel stroke. The clearance under the tyre is reduced by the deflection of the unloaded tyre.

FR = Clearance

LH = Lift stroke

R_{st} = Half tyre diameter laden

R = Half tyre diameter unladen

Clearance under the tyre

$$FR = LH - (R - R_{st})$$

$$LH \text{ min.} = 100 \text{ mm}$$

4.1.10 Axle lift | Double-sided axle lift

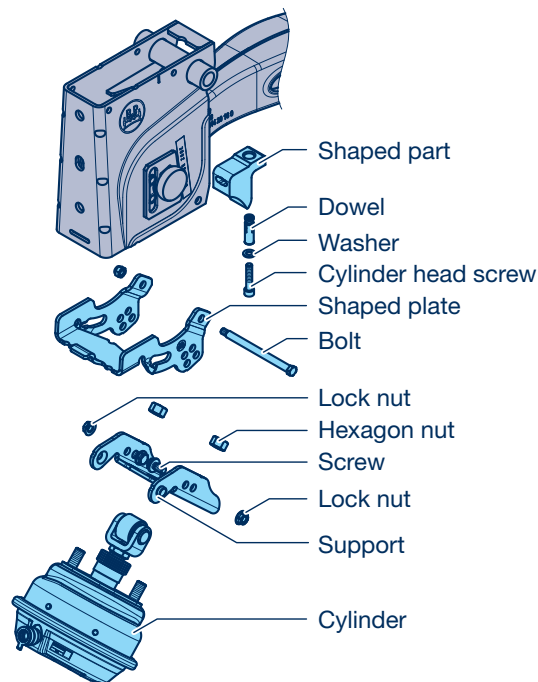
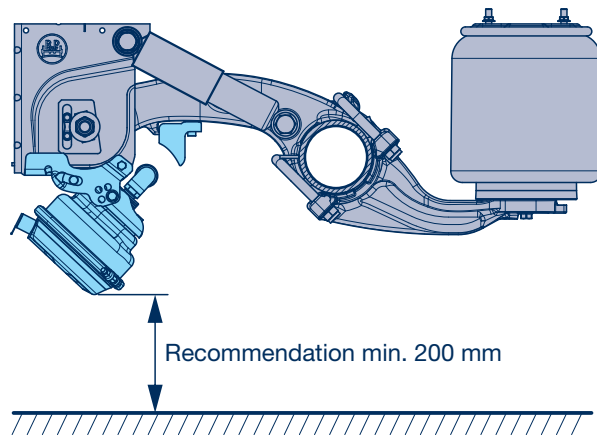

The two-sided lift is suitable for disc and drum brakes.

The design is such that the spring bolt is not required for the function of the axle lift. This means there is no need to remove the spring bolt when installing the axle lift. As a result, installation is much more straightforward.

The two-sided axle lift is mounted under both hanger brackets of a module, is therefore within the assembly clearance and does not collide with vehicle equipment such as e.g. pallet boxes.

Function

In this axle lift, the lifting force is also generated by one integrated diaphragm cylinder on each side.

Assembly

The shaped plate is hooked onto the front side of the hanger bracket (punched recess) and connected to the hanger bracket on the reverse side with a bolt.

The pre-assembled support with diaphragm cylinder is then connected to the shaped plate with 2 screws and lock nuts.

The position for setting out the stop is shown in the BPW technical documents.

The shaped part is placed onto the projection on the lower side of the trailing arm, the dowel is knocked in and then secured using the cylinder head screw (with washer).

If a TS2 3709 or TS2 4309 disc brake with spring-loaded cylinders is installed on the axle, these must be dismantled for installation of the two-sided axle lift in order to be able to secure the shaped part with the cylinder head screw on the underside of the trailing arm.

Tightening torques *see chapter 4.1.11*.

Advantages:

- Can be used for disc and drum brake axles
- Installation space in front of the hanger brackets and in the centre of the vehicle remains free
- Subsequent assembly possible without any problems
- Compact design, good ground clearance
- Low weight, robust construction
- Installation position can be set for different suspension types



The installation position and mounting of the axle lift device can be seen in the BPW technical documents (air suspension data sheets) and the supplied installation drawing.

The pinning position must be correct for the design and ride height (holder with shaped plate by screw) to ensure reliable functions.

4.1.10 Axle lift | Side axle lift

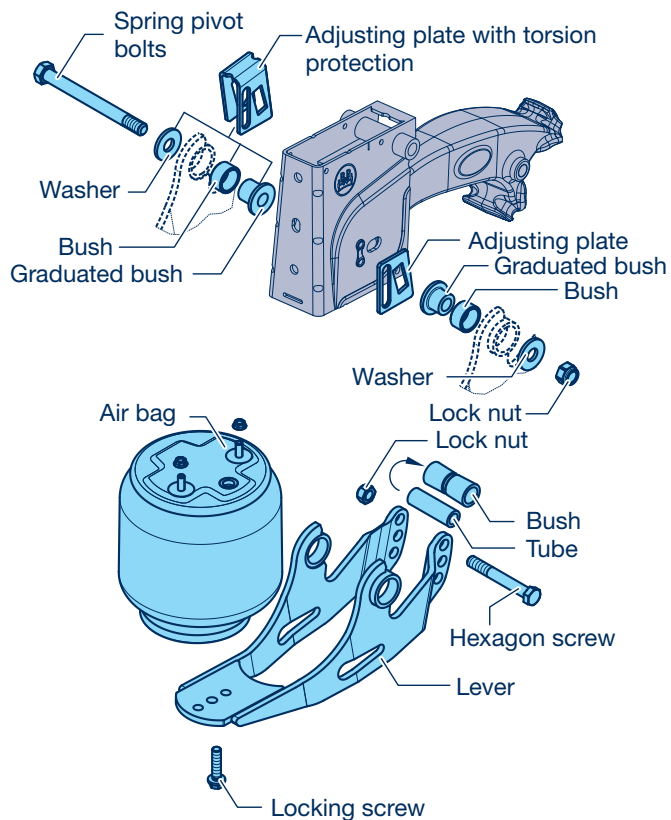
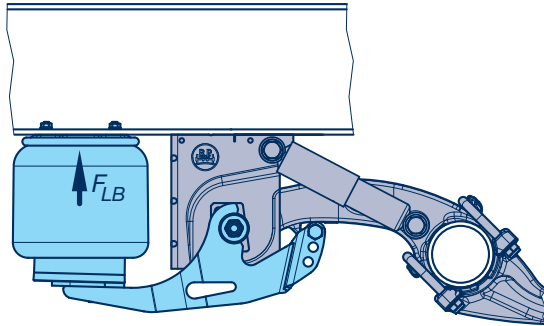

Side location is suitable for raising the front axle of the suspension unit. The lifting arm is mounted on the front hanger bracket under the trailing arm.

The air bag sits centrally on the lifting arm ($V = 0$ mm) and is attached under the vehicle long-beam.

Additional crossmembers are not required.

The top plate of the lifting bag can be offset to the side by ± 20 mm.

The air pressure for the air bag should be limited by a reducing valve at 5 bar, depending on the design!

Force on lifting bag BPW 30 ($p = 5.0$ bar):

$$F_{LB} = \frac{5.0 \text{ bar}}{0.00023 \text{ bar/N (spec. air bag pressure)}} = 21,750 \text{ N}$$

The dynamic axle movements are not transferred to the axle lift device and therefore no consistent initial pressure is required in the lifting bag, even if the axle lift is not being operated.



The installation position and mounting of the axle lift device can be seen in the BPW technical documents (air suspension data sheets) and the supplied installation drawing.

Assembly

In the event of retro-fitting, the spring bolt in the spring eye is replaced by a longer hexagon bolt (M 24).

The spring bolt is secured against rotating by the use of an adjusting plate with anti-rotation lock.

1. Remove the old spring bolt.
2. Position the bush and stepped bush in the lever, attach the adjusting plate with anti-rotation lock and add the disc.
3. Insert the new spring bolt (hexagon bolt).
4. Pre-assemble the other side in the same manner (if necessary, fix the adjusting plate on the hanger bracket with grease).
5. Lift the lever until the holes in the lever and hanger bracket are aligned and push the spring bolt through the hanger bracket.
6. Insert the disc, screw on the lock nut while counter-holding the spring bolt.
7. Assemble the air bag.

Tightening torques [see chapter 4.1.11](#).

4.1.10 Axle lifts | Central axle lift

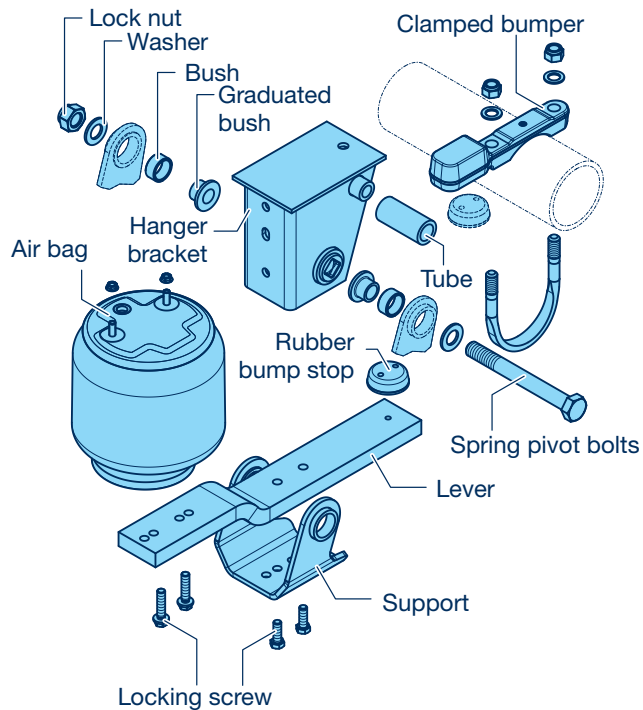
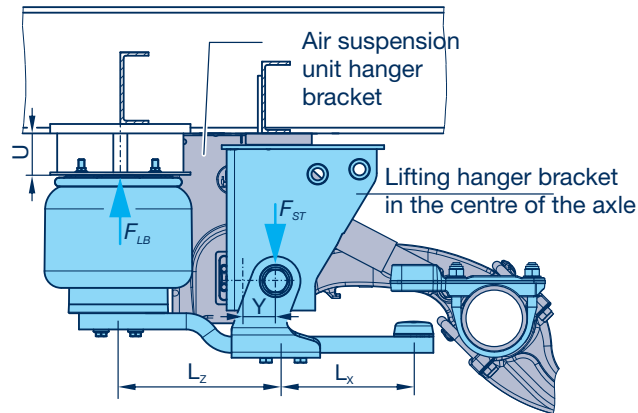

The lifting device can be arranged in the centre of the axle for raising the central (rear) suspension axle or if space is limited.

This axle lift device is located on the vehicle centre line and is attached to the crossmember via an additional hanger bracket.

The length of the hanger bracket can be seen in the technical documentation. The lifting bag forces are also to be counteracted by a crossmember.

The air pressure for the lifting bag must be limited by a reducing valve to 5 bar, depending on the design!

Example

- Axle lift device with lifting bag BPW 30
- Pressure reduction valve set at 5 bar.
- Lever lengths $L_x = 280 \text{ mm}$ / $L_z = 320 \text{ mm}$ (from BPW technical documents BPW)

Force on lifting bag BPW 30 ($p = 5.0 \text{ bar}$):

$$F_{LB} = \frac{5.0 \text{ bar}}{0.00023 \text{ bar/N (spec. air bag pressure)}} = 21,750 \text{ N}$$

Force of hanger bracket ($p = 5.0 \text{ bar}$):

$$F_{ST} = \frac{21,750 \text{ N} \times 600 \text{ mm}}{280 \text{ mm}} = 46,600 \text{ N}$$

If the crossmember over the lifting air bag is not fitted, the torsion moment ($F_{LB} \times LZ$) of the lifting hanger bracket crossmember must be counteracted.

The crossmember must be dimensioned according to standard safety reserves in the commercial vehicle industry.

Tightening torques *see chapter 4.1.11.*



The installation position and mounting of the axle lift device can be seen in the BPW technical documents and the supplied installation drawing.

4.1.11 Tightening torques

Lightly grease thread, except spring bolt

Area	Item	Attachment	Thread	Tightening torque
Spring bolts	1	Spring bolts	M24 x 2	650 Nm (605 - 715 Nm)
	2	Spring bolt / gusset plate	M18 x 1.5	420 Nm (390 - 460 Nm)
Shock absorber	3	Upper and lower attachment	M24	420 Nm (390 - 460 Nm)
Air bag	4	Upper plate attachment	M12	66 Nm
	5	Lower attachment	M16	300 Nm
	6	Central bolt		300 Nm
Axle lift device	7	Double-sided axle lift, diaphragm cylinder attachment	M16	190 Nm (180 - 210 Nm)
	8	Double-sided axle lift, shaped plate / support attachment	M12	75 Nm
	9	Two-sided axle lift, attachment of molded part to trailing arm	M10	50 Nm
	10	Double-sided axle lift, double-sided axle lift attachment	M10	38 Nm
	11	Sidewise mounted axle lift, roller at lever attachment	M20	350 Nm (325 - 385 Nm)

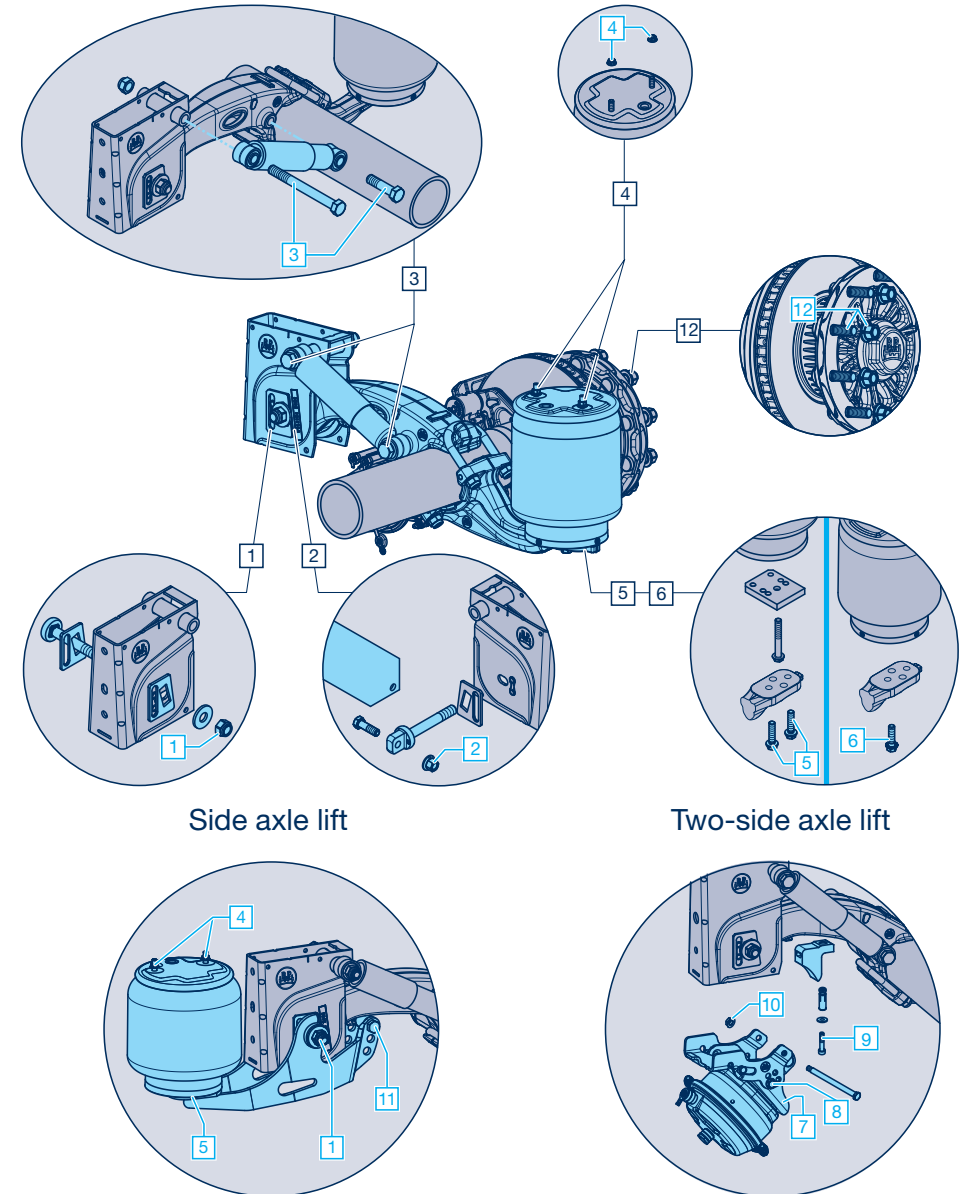

4.1.12 Surface treatment

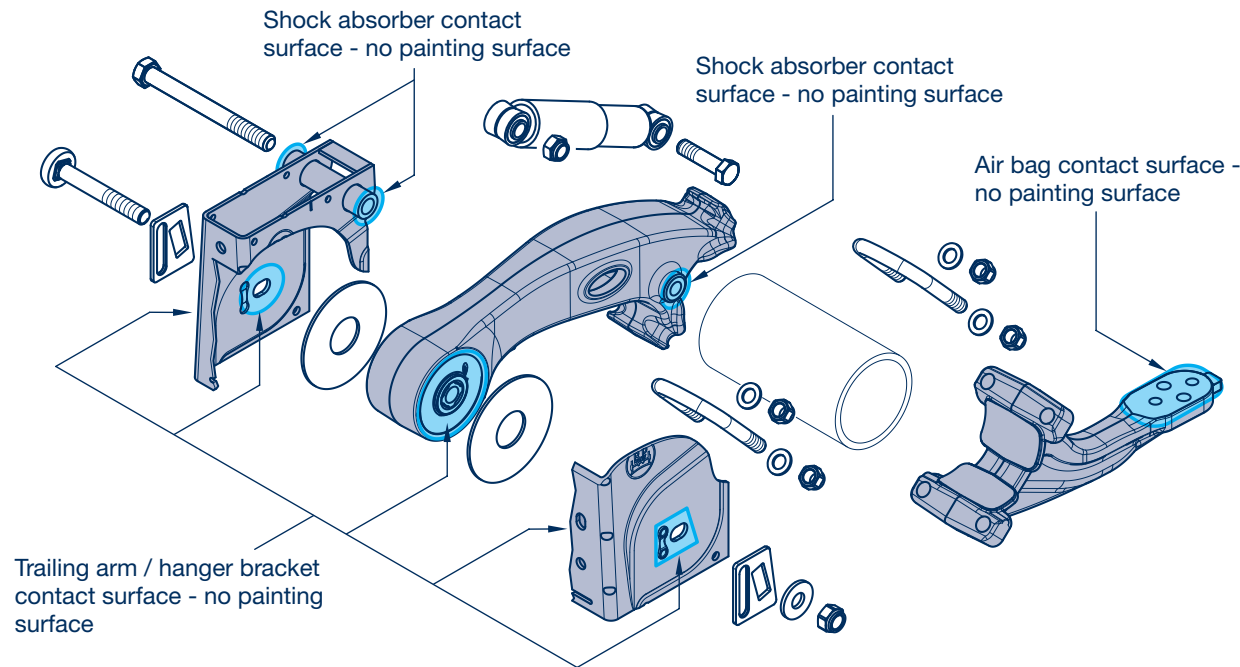

BPW running gears come with KTL + Zn anti-corrosion coating (cathodic dip coating with zinc phosphating) which undergoes salt-spray testing in accordance with DIN EN ISO 9227. Practical tests show that this KTL+Zn surface treatment is even more resistant to corrosion than conventional primers and subsequent topcoats. There is therefore no need for conventional topcoats on KTL+Zn-treated components, unless there are special colour and gloss requirements. The KTL+Zn coating can generally be top-coat-

ed with single-component, air-drying synthetic resin-based vehicle chassis paints as well as two-component, solvent-based or water-based coating systems. However, emulsion paints, architectural paints or nitrocellulose paints must not be used.

When applying the top coat, it must be ensured that the following areas of the running gear have been covered or masked: wheel contact surfaces, booster bracket contact surfaces to the drum brake cylinder and their attachment nuts, brake discs, brake lining shaft, exciter

rings, ABS sensors, disc brake cylinder contact surfaces (unless already installed), all hanger bracket contact surfaces (internal and external) and the bolt-on parts of the spring bolt bearing, bolt-on parts of the shock absorbers and the air bag contact surface on the air bag carrier.

The reason is that contact surfaces between dynamically loaded and bolted components are subject to micro-movements which result in the destruction of the coating and gaps forming at a later date. The clamping assembly could detach as a result.

The total thickness of the coating must not exceed 30 µm on the contact surfaces of the bolt-on parts of the hanger brackets. For hot-dipped hanger brackets, the maximum coat thickness around the bolt-on parts is 100 µm.

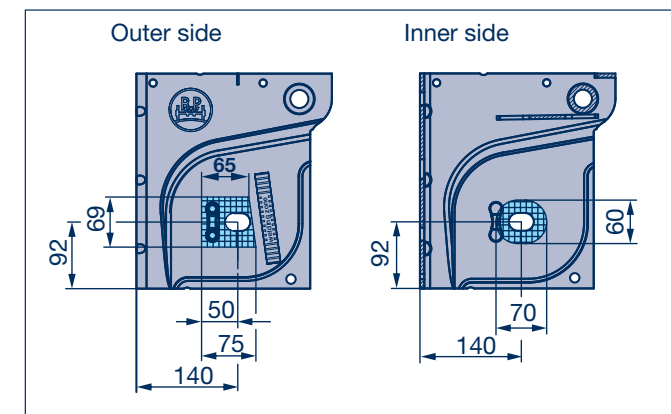

4.1.13 Characteristic curves and data sheets on My BPW | TE-1242.0 Characteristic curves for air bag

The characteristics curves serve to estimate the load index of the air bags which declines over the stroke, e.g. for the raising and lowering function. A diagram sheet is available for each air bag type and each transmission ratio between the trailing arm and air bag support (L1, L2). The iso bars (from 1 bar to 8 bar air bag pressure, from TE-1188.0) describe the relation between the lifting capacity (of the suspended dimensions per axle) and stroke in the sense of the axle spring deflection between minimum ride height (empty, without air) and maximum ride height (fully extended air bag). The following applies approximately for the suspended dimensions and axle load (axle load on the ground less the weight force of axle, wheels and part of the suspension):

$$FA_{gef} = FA \times 0.92$$

[Characteristics curves for air bags](#)

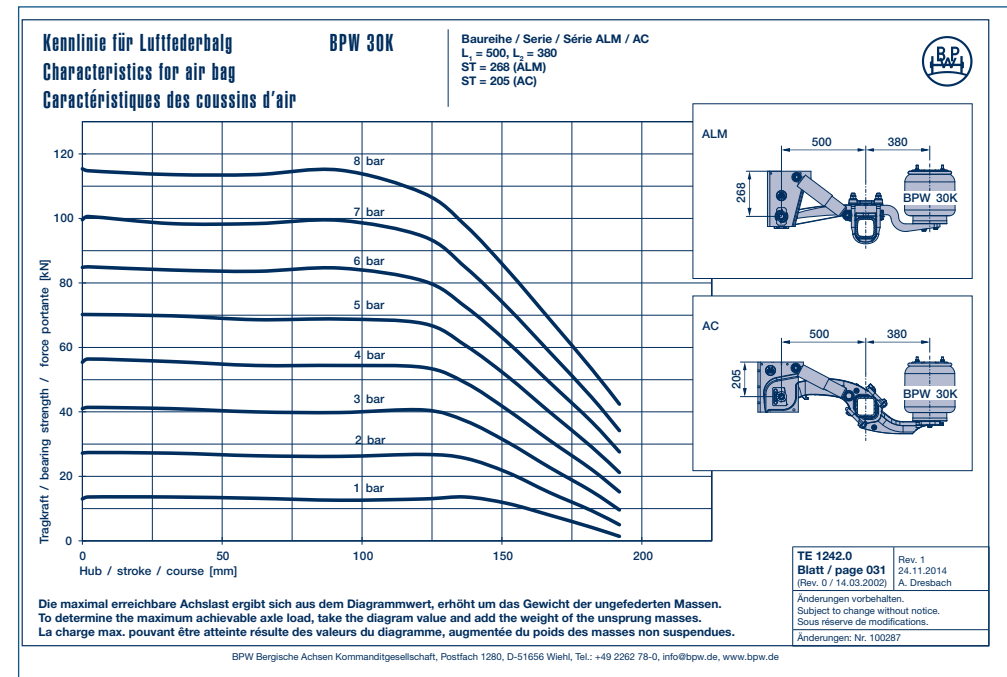

4.1.13 Characteristic curves and data sheets on My BPW | TE-1188.0 Air bag pressure diagrams

The characteristics curves serve to determine the air bag pressures based on the load status of the axles. There is a diagram sheet for each air bag type and each transmission ratio between the trailing arm and air bag support (L1, L2). The straight lines are allocated to the maximum axle loads and describe the relation between the air pressure in the air bags and weight ratio (part load / full load of the axle loads on the ground GA).

[Air bag pressure diagrams](#)

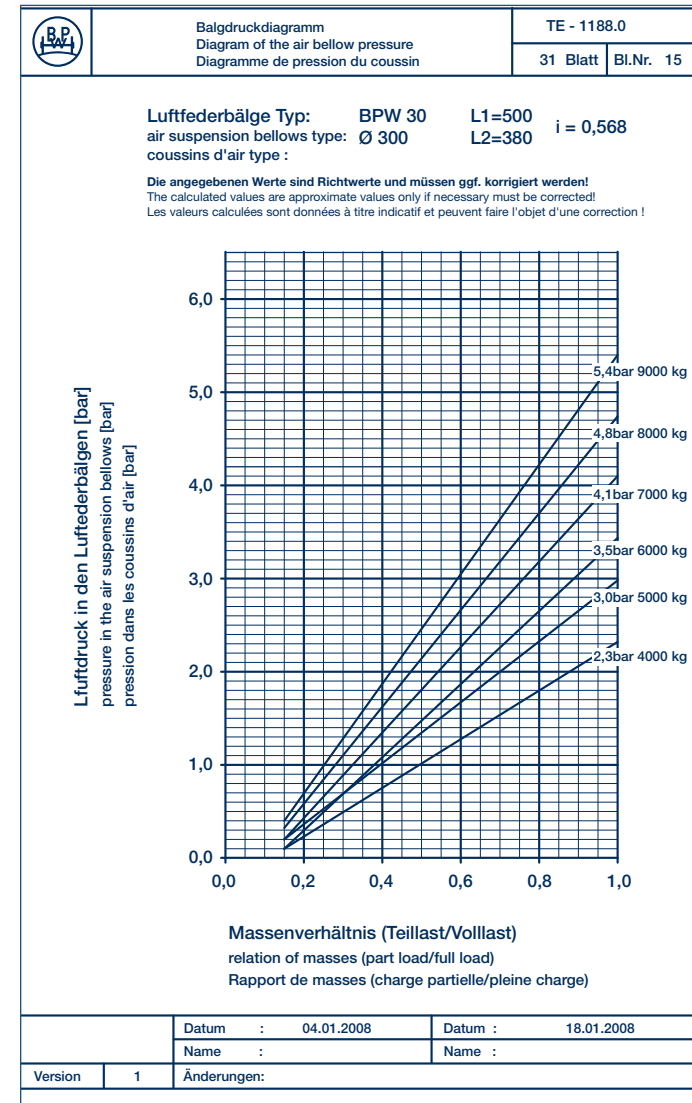

4.1.13 Characteristic curves and data sheets on My BPW | Air bag Data Sheets EA

BPW provides a comprehensive collection of data sheets for its air suspension running gear on its website (My BPW). These data sheets describe the most economical solutions according to technical requirements.

The weight tables are below the ride height overview. The centre of gravity heights stated for the trailer are limited by the mechanical tensions of the running gear components. This does not affect the rolling stability of the running gear.

The "Required characteristics" table describes the recommended uses in the on-road and off-road categories. The suitable air suspension programmes (EA, AL II or SL) are specified, based on the required axle load.

The configuration sheets are sorted according to ride height, axle load, brake type and size (TS2 4309, TS2 3709, SN 4218) and air bag design. The last sheets describe the axle lift devices.

The designation of data sheet page number and row clearly defines an air suspension design. The axle executions shown, including tyre recommendation, refer to the common standard. Special versions which incur additional costs can be considered on request.

ECO Air
Air suspension axles with disc brake TS2 4309
Ride height 205 - 510 mm Standard air bags
EA Sheet 1a

Line	Series EA..	Adjustable ride height FH					Total spring travel GF ¹⁾	Air bag type BPW	Shock absorber (reinforced) 02.37.....	Trailing arm		Air bag beam		Hanger bracket		Packer B ²⁾
		for single axles	for axle units	min. FH with axle raised	empty without air	loaded without air				LH	Typ	TH	Typ	ST	F	
1	205-255	215-255	245	145	130	190	30K / 36K	...22.79.02	60	A	155	U				
2	235-305	245-305	275	175	160	220	30 / 36	(...32.05.02)								
3	245-295	255-295	285	185	170	190	30K / 36K	...22.89.02	130	B	-10	O	O-335	290	67	40
4	275-345	285-345	315	215	200	220	30 / 36	(...32.07.02)								
5	300-370	310-370	340	240	225	220	30 / 36	...22.83.02								
6	330-380	340-380	370	270	255	190	30K / 36K	(...22.04.02)								
7	360-425	370-425	400	300	285	220	30 / 36	...22.88.02								
8	390-460	400-460	430	330	315	220	30 / 36	(...32.06.02)								
9	415-485	425-485	455	355	340	220	30 / 36	...22.88.02								
10	450-510	460-510	490	390	375	220	30 / 36	(...32.06.02)								

¹⁾ Lifting heights acc. to TD-1242.0
²⁾ The packer is not included in supplied package.

Axle type	Track SP	Spring centre FM	Tyres recommended	Height of centre of gravity ³⁾
SRBF 9010	2040	1200	385/65 R22.5 385/55 R22.5	2500
	2095	1300		2700
	2140	1400		2850

³⁾ Calculation reference: 0.4 g acceleration at right angles, side tilt body approx. 3.5° without taking account the tipping limit and tyre damping.

- > Max. inclination angle of the semitrailer under full load and lowest adjustable ride height ±1°
- > Bag pressures acc. to TE-1188.0 sheet 15 (30/30K), sheet 11 (36/36K)
- > The hanger brackets, air bag supports and the frame must be reinforced so that the forces applied can be absorbed. See the current BPW installation instructions.

Example name SKRBF EAAU 9010 V 30K

SRBF	EAAU	9010	V	30K
Axle type	Series Air suspension	Axle type	Hanger bracket, adjustable	Air bag type

Rev. 2 | 2019-12-09
 Subject to change without notice

[Data sheets air suspension gears](#)

4.1.13 Characteristic curves and data sheets on My BPW |

Pendulum examination using the EAAU as an example

The adjustable ride heights (vertical distance between the centre of the axle and upper edge of the hanger bracket) are stated separately for single axles (for single axle trailers, but also for turntable drawbar trailers) and multi-axle units. A greater minimum ride height is recommended for the latter to accommodate 10 mm additional upward travel. It is required due to the potential vehicle tilt ($\pm 1^\circ$).

If an axle lift device is to be installed, the distance must not be less than the adjusted minimum ride heights to ensure that there is sufficient space for the stroke. "Empty without air" describes the minimum ride height when the supporting air bags are in an unpressurised condition in an empty vehicle. The "loaded without air" ride height value is 15 mm lower due to the mechanical deformation of the components in a fully loaded vehicle. The overall spring deflection is determined by the air bag and describes the vertical spring deflection of the axle between the "empty without air" ride height and maximum achievable downward travel.

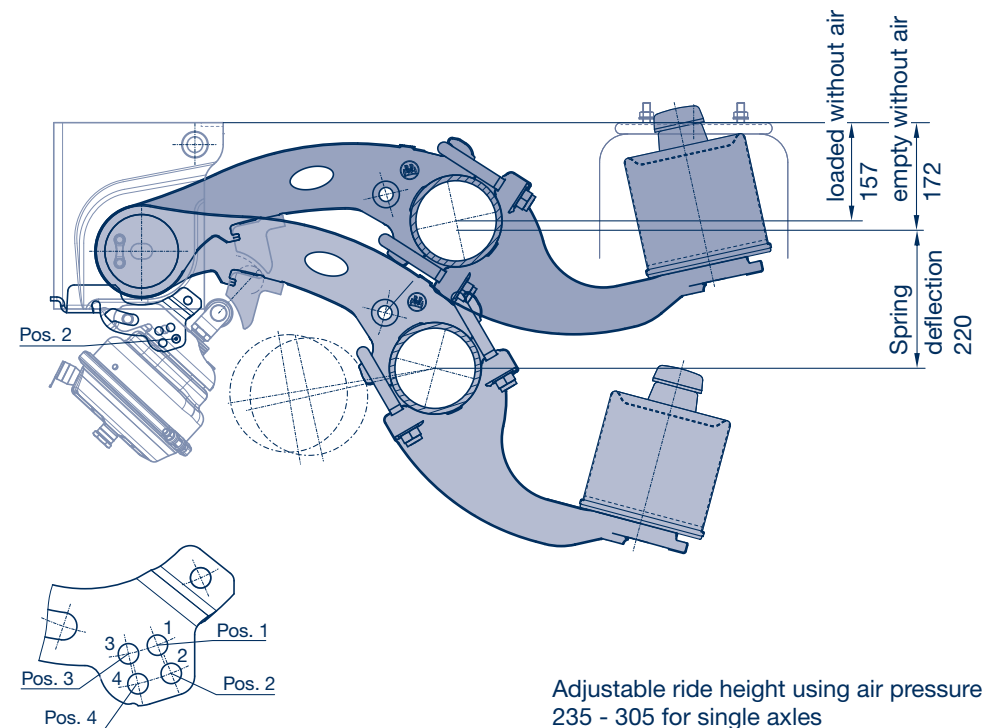

Pinning position for the two-sided axle lift

Adjustable ride height using air pressure
 235 - 305 for single axles
 245 - 305 for multi-axle units
 275 min. ride height for lift axle

4.2 Air suspensions Airlight II and SL

4.2.1 Notes and design | Notes on the content

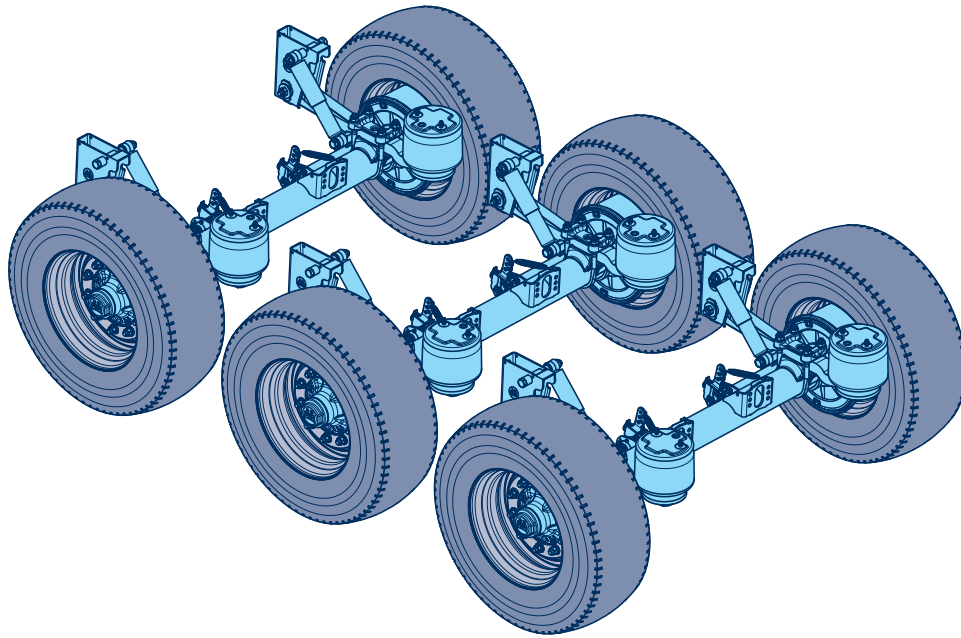

Overview of the air suspension series
[see chapter 1.2.3](#)

With this chapter we would like to present the technical guidelines of the constructions and give installation recommendations.

Please note that the drawings in the guidelines are examples only and dimensions depend exclusively on the vehicle type and its operating conditions. This data is only known to the vehicle manufacturer who must incorporate it in their design.

Chapter 4.2.2 contains equations and calculation examples from BPW to assist in determining the various stresses. The safety factors for the constructional design of the vehicle frame and substructure must be defined by the vehicle manufacturer.

Detailed design data for and characteristics of BPW air suspensions such as dimensions, permitted centre of gravity, etc. can be found in the technical documents (air suspension data sheets and offer drawings).

The warranty shall lapse if installation of the BPW running gear system does not correspond to technical guidelines as per current BPW installation instructions. The BPW warranty is **only** valid for the complete ECO Plus air-suspended running gear systems, which have been selected appropriately for their respective use.

For further information, please refer to the current valid service and maintenance instructions or the ECO Plus Guarantee brochure.

[Maintenance instructions](#)

[ECO Plus Warranty documents](#)

4.2.1 Notes and design | Features of the AL II / SL suspension systems

Airlight II (AL II)

- Axle load range 9 t – 12 t
- 70 mm wide trailing arms made of spring steel
- Spring seat clamped or welded
- Alignment through adjustable hanger brackets as standard
- Spring bolt M 24

SL

- Axle load range 12 t – 14 t
- 100 mm wide trailing arms made of spring steel
- Spring seat welded
- Hanger brackets, rigid or adjustable
- Spring bolt M 30

4.2.1 Notes and design | Construction description

General

The combination of axle and air suspension (running gear system) can be used as single and multiple axle and suspension unit in the vehicle. The modular BPW concept of the multi-component assembly axle - trailing arm provides a maximum of adaptation options. The integrated vertical stop (bump stop in the air bag) ensures that the connection of the running gear to the vehicle frame only has to be created through the hanger brackets and air bags.

For suspensions with more than three axles, long-stroke air bags are required to ensure that all axles maintain ground contact even on uneven ground. Hydraulic suspensions with special BPW components should be used for suspensions with more than 6 axles.

Trailing arm and stabilizer function

The trailing arms (between axle and hanger brackets) transfer the wheel forces to the hanger bracket and are positioned in it through a steel / rubber / steel bush. Whilst air suspension is always used for the pure vertical movement, the body rolling of the vehicle and one-sided driving through dips or obstacles are compensated by the trailing arms (body rolling suspension). The U-shape configuration of axle beam and two trailing arms acts as a stabilizer to counteract the side tilt of the vehicle during lateral acceleration. The body roll stability can be supported with an additional stabilizer in special conditions.

4.2.1 Notes and design | Design description

Axle and brake load equalisation

All air bags are connected with one another through air pipes. Uneven driving surfaces or vehicle tilts therefore do not create different axle loads within the multiple axle and suspension unit. The brake forces are also evenly distributed across all axles. BPW air suspension running gear systems therefore provide maximum driving safety and minimal tyre wear.

Suspension and shock absorbers

To achieve the optimal combination of safe and comfortable driving and minimal wear, the air bags and shock absorbers are perfectly matched up with their characteristic curves and installation diagrams. The oscillating movement (vertically and body roll) is absorbed effectively and the wheels retain optimal road contact.

Vertical, longitudinal and lateral forces

The vertical forces are distributed across hanger brackets and air bags. Longitudinal forces (from uneven road surfaces and due to braking) as well as lateral forces, on the other hand, are exclusively applied to the vehicle frame through the hanger bracket. Without an adjusted brace, which must be professionally made by the vehicle manufacturer, the lateral forces cannot be transferred from the hanger bracket to the frame.

Raising and lowering; axle lifting device

The air suspension facilitates the quick adjustment of the ride height through a switch or rotary disc valve for various loading and unloading processes. This typically involves adjustment to loading ramps or lowering for safe tipping. The also optional axle lift device (axle lift) for one or several axles makes it possible to influence the axle load distribution in an articulated truck and also the turning circle required. Tyre wear and fuel consumption are also reduced on trips with partial loads and manoeuvrability is improved.

Installation and tracking

BPW vehicle components are designed for the simplest possible installation and maintenance. A tracking device integrated in the hanger bracket and spring seat clamping make it possible to adjust the wheel alignment more quickly when required. BPW provides a tack welding device for initial installation, ([see page no. 192](#)) for optimally positioning hanger brackets and air bag brackets.

4.2.2 Force calculations | Straight line travel

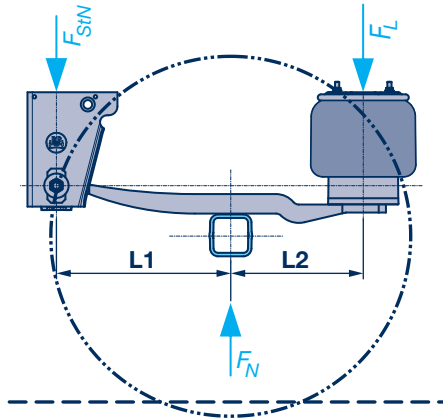

Driving mode straight ahead:

(without consideration of unsprung masses)

$$F_A = G_A \times g$$

$$F_N = \frac{F_A}{2}$$

$$F_{StN} = F_N \times \frac{L2}{L1 + L2}$$

$$F_L = F_N \times \frac{L1}{L1 + L2}$$

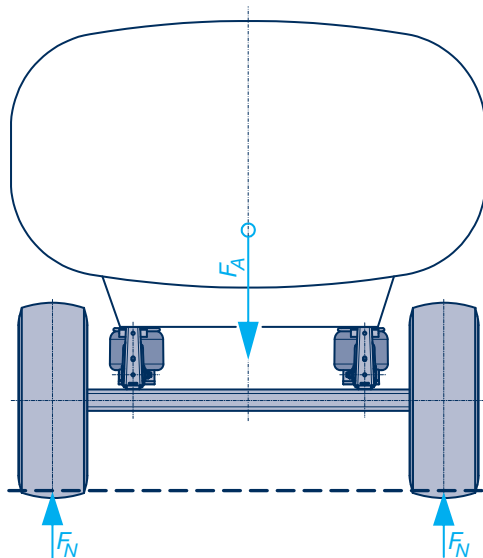

G_A = Vehicle load (kg)

g = Gravitational acceleration (9.81 m/s²)

F_A = Vehicle force (N)

F_N = Wheel force on ground (N)

$L1$ = Front trailing arm length (mm)

$L2$ = Rear trailing arm length (mm)

F_{StN} = Hanger bracket force from wheel force on ground (N)

F_L = Force on air bag (N)

Example:

SHSFALM 9010 30 ECO Plus 3

$$L1 = 500 \text{ mm}$$

$$L2 = 380 \text{ mm}$$

$$F_A = 9,000 \text{ kg} \times 9.81 \text{ m/s}^2 = 88,290 \text{ N}$$

$$F_N = \frac{88,290 \text{ N}}{2} = 44,145 \text{ N}$$

$$F_{StN} = 44,145 \text{ N} \times \frac{380}{500 + 380} = 19,063 \text{ N}$$

$$F_L = 44,145 \text{ N} \times \frac{500}{500 + 380} = 25,082 \text{ N}$$

4.2.2 Force calculations | Forces during braking

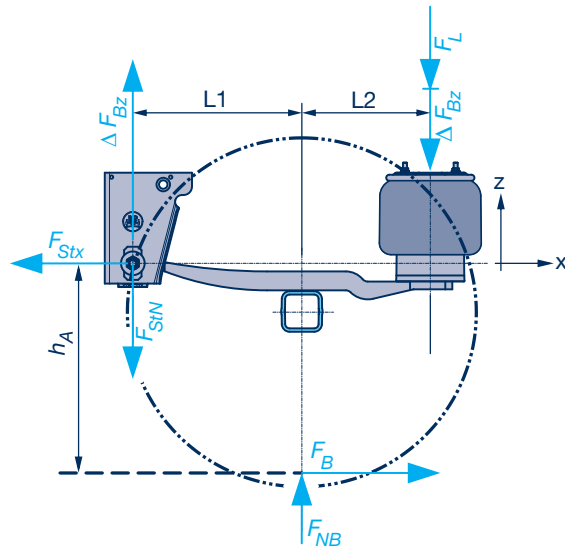

F_{NB} = Wheel force on ground during braking (N)

ΔF_A = Axle load shift during braking (N)
(depends on vehicle design, particularly important for trailer front axles)

F_{StN} = Hanger bracket force from wheel force on ground (N)

F_L = Force on air bag (N)

F_B = Braking force (N)

z = Braking rate (%)

ΔF_{Bz} = Reaction force from braking torque (N)

h_A = Height of spring bolt over road surface

F_{Stx} = Total force on the air suspension hanger bracket in direction x (N)

F_{Stz} = Total force on air suspension hanger bracket in direction z (N)

$F_{Lges.}$ = Total force on the air bag (N)

Normal forces from axle load:

$$F_{NB} = \frac{F_A \pm \Delta F_A}{2}$$

$$F_{StN} = F_{NB} \times \frac{L2}{L1 + L2}$$

$$F_L = F_{NB} \times \frac{L1}{L1 + L2}$$

Brake force:

$$F_B = \frac{z}{100} \times F_{NB}$$

Forces from braking torque support:

$$\Delta F_{Bz} = \frac{F_B \times h_A}{L1 + L2}$$

Total force on the hanger bracket in direction x:

$$F_{Stx} = F_B$$

Total force on the hanger bracket in direction z:

$$F_{Stz} = F_{StN} - \Delta F_{Bz}$$

Total force on the air bag:

$$F_{Lges.} = F_L + \Delta F_{Bz}$$

Example:

SHSFALM 9010 30 ECO Plus 3

$$F_A = 88,290 \text{ N}$$

$$\Delta F_A = \text{Assumed in Example 0}$$

$$F_{NB} = \frac{88,290 \text{ N}}{2} = 44,145 \text{ N}$$

$$F_{StN} = 44,145 \text{ N} \times \frac{380}{500 + 380} = 19,063 \text{ N}$$

$$F_L = 44,145 \text{ N} \times \frac{500}{500 + 380} = 25,082 \text{ N}$$

$$z = 80 \%$$

$$F_B = 0.8 \times 44,145 \text{ N} = 35,316 \text{ N}$$

$$h_A = 600 \text{ mm}$$

$$\Delta F_{Bz} = \frac{35,316 \text{ N} \times 600}{880} = 24,079 \text{ N}$$

$$F_{Stx} = 35,316 \text{ N}$$

$$F_{Stz} = 19,063 \text{ N} - 24,079 \text{ N} = -5,016 \text{ N}$$

$$F_L = 25,082 \text{ N} + 24,079 \text{ N} = 49,161 \text{ N}$$

4.2.2 Force calculations | Cornering

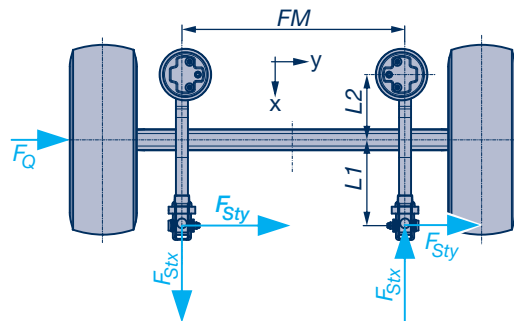
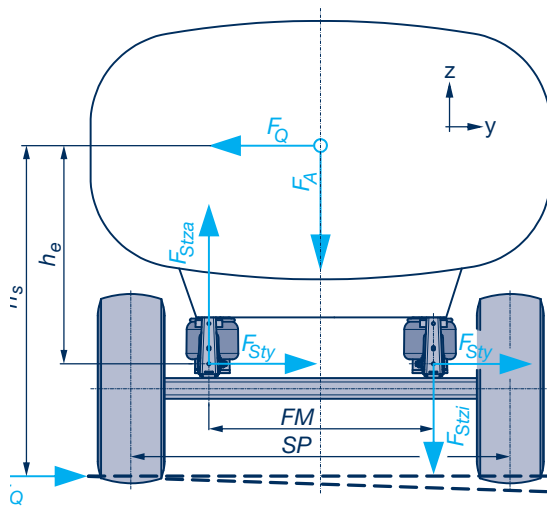

- F_A = Vehicle force (N)
 F_Q = Centrifugal force at the over-balance limit (N)
 F_{Stza} = Hanger bracket force at curve outer side (N)
 F_{Stzi} = Hanger bracket force at curve inner side (N)
 h_s = Centre of gravity height above road surface
 h_e = Centre of gravity height above trailing arm bolt

Driving at the tilting limit:

(without considering effect of springs and weight of unsprung masses; proximity calculation)

$$F_Q = \frac{F_A \times SP}{h_s \times 2} = \frac{F_A}{g} \times a_{quer}^*$$

Hanger bracket forces:

$$F_{Stza} = \left(\frac{F_A}{2} \times \frac{L2}{L1 + L2} \right) + \frac{F_Q \times h_e}{FM}$$

$$F_{Stzi} = \left(\frac{F_A}{2} \times \frac{L2}{L1 + L2} \right) - \frac{F_Q \times h_e}{FM}$$

$$F_{Sty} = \frac{F_Q}{2} \text{ (Assumption)}$$

$$F_{Stx} = \pm \frac{F_Q \times L1}{FM}$$

* BPW can provide an accurate a_{quer} calculation in accordance with ECE R 111 on request (tilting stability calculation).

The track width and centre of gravity height have the main influence on the tilting angle. The calculation also accounts for the geometrical running gear design (steering, roll centre) as well as the rigidity of trailing arms, axle beams, bags and tyres. The lateral acceleration at the tilting limit and vehicle body tilting angle are the result of the calculation.

- F_{Sty} = Lateral force at the hanger bracket
 F_{Stx} = Longitudinal force at the hanger bracket
 FM = Spring centre
 SP = Track width
 g = Gravitational acceleration (9.81 m/s²)
 a_{quer} = Lateral acceleration at the over-balance limit (m/s²)

Example:
SHSFALM 9010 30 ECO Plus 3

$$SP = 2,040 \text{ mm}$$

$$FM = 1,300 \text{ mm}$$

$$h_s = 2,000 \text{ mm}$$

$$h_e = 1,400 \text{ mm}$$

$$F_A = 88,299 \text{ N}$$

$$L1 = 500 \text{ mm}$$

$$L2 = 380 \text{ mm}$$

$$F_Q = \frac{88,290 \text{ N} \times 2,040}{2,000 \times 2} = 45,028 \text{ N}$$

$$F_{Stza} = \left(\frac{88,290 \text{ N}}{2} \times \frac{380}{880} \right) + \frac{45,028 \text{ N} \times 1,400}{1,300} = 67,554 \text{ N}$$

$$F_{Stzi} = \left(\frac{88,290 \text{ N}}{2} \times \frac{380}{880} \right) - \frac{45,028 \text{ N}}{1,300} \times 1,400 = -29,429 \text{ N}$$

$$F_{Sty} = \frac{45,028 \text{ N}}{2} = 22,514 \text{ N (Annahme)}$$

$$F_{Stx} = + \frac{45,028 \text{ N}}{1,300} \times 500 = \pm 17,318 \text{ N}$$

4.2.2 Force calculations | Turning when stationary

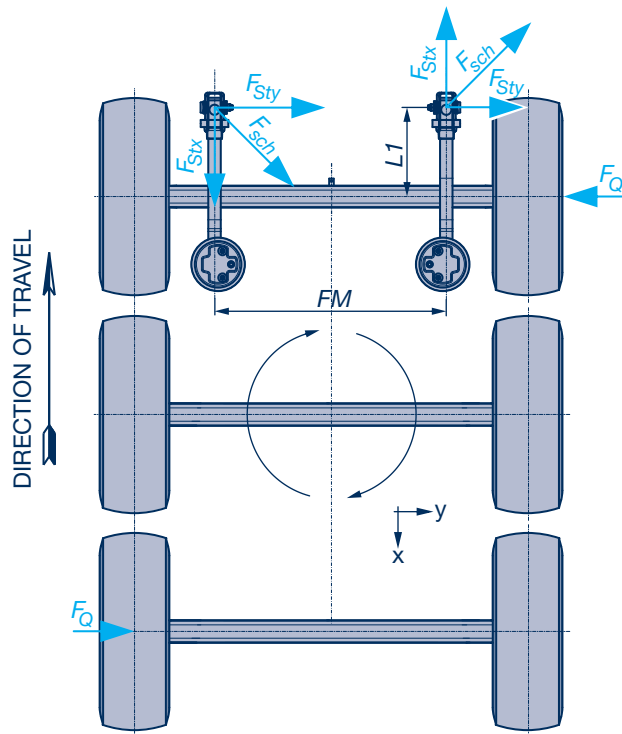

1st or 3rd axle in a rigid tri-axle suspension

The lateral forces are transferred through the two outer axles. The central axle turns on its own axis and does not transmit lateral forces.

$$F_Q = F_A \times \mu_Q$$

$$F_{Stx} = \pm \frac{F_Q \times L1}{FM}$$

$$F_{Sty} = \frac{F_Q}{2} \text{ (Assumption)}$$

Example:

SHSFALM 9010 30 ECO Plus 3

$$FM = 1,300 \text{ mm}$$

$$L1 = 500 \text{ mm}$$

$$F_A = 9,000 \text{ N} \times 9.81 = 88,290 \text{ N}$$

$$\mu_Q = 1.6$$

$$F_Q = 88,290 \text{ N} \times 1.6 = 141,260 \text{ N}$$

$$F_{Stx} = \frac{141,260 \text{ N}}{1,300} \times 500 = 54,331 \text{ N}$$

$$F_{Sty} = \frac{141,260 \text{ N}}{2} = 70,630 \text{ N}$$

F_{sch} = Resulting shear force (N)

F_Q = Lateral force on axles (N)

μ_Q = Traction coefficient when turning
(from tests: $\mu_Q = 1.6$)

4.2.3 Installation and welding specifications of hanger brackets

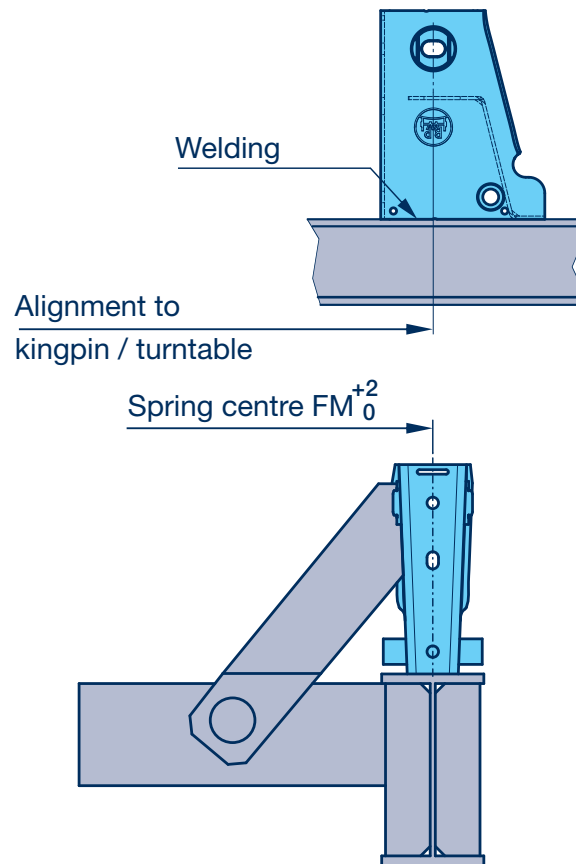

As a rule, air suspension axles are installed with the vehicle frame on its back.

Welding on loose hanger brackets

For BPW Airlight II / SL air suspensions with loose hanger brackets, the hanger brackets are first welded to the vehicle frame.

The spring bolt bearing points of the hanger brackets are positioned precisely to the longitudinal centre line of the vehicle using the centre of kingpin or turntable. In this installation position, the tolerances of the spring centres and trailing arm lengths must be taken into consideration.

The hanger bracket position in the sideways direction must be kept within the tolerance range FM (0, +2) to avoid stresses in the axle unit. The gussets can then be welded on. Check the track and correct if necessary after welding on the hanger brackets or mounting the axles (see Alignment, [see chapter 2.8](#)).

4.2.3 Installation and welding specifications of hanger brackets

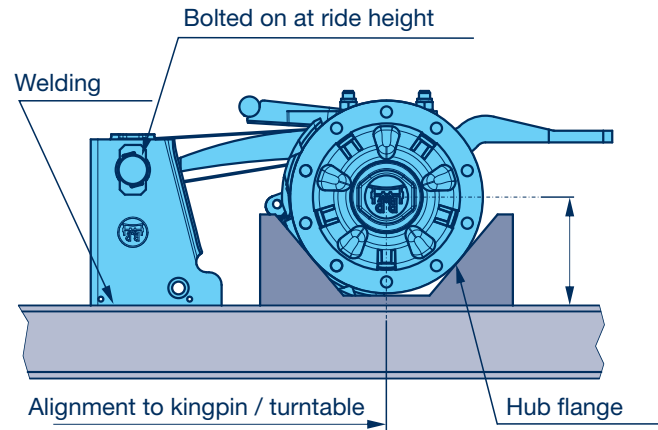

Installation of pre-assembled air spring modules

BPW Airlight II / SL air suspensions with assembled trailing arms and hanger brackets are generally incorporated at the hub flange, arranged according to the vehicle design and aligned precisely to the longitudinal centre line of the vehicle using the centre of kingpin or turntable.

The hanger brackets are welded to the vehicle bottom flange.

Welding instructions [see page no. 191](#)

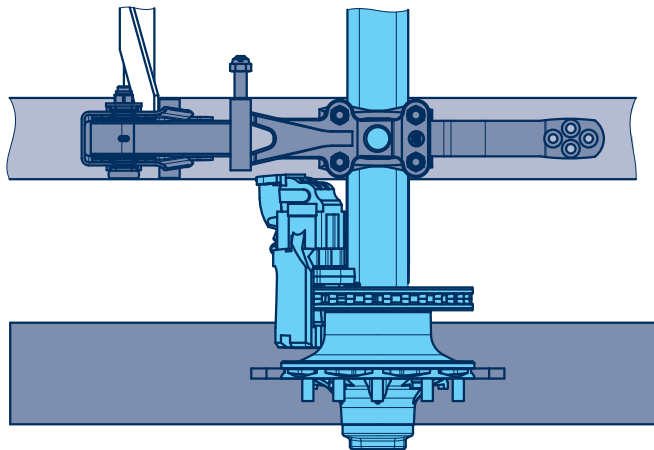

4.2.3 Installation and welding specifications of hanger brackets

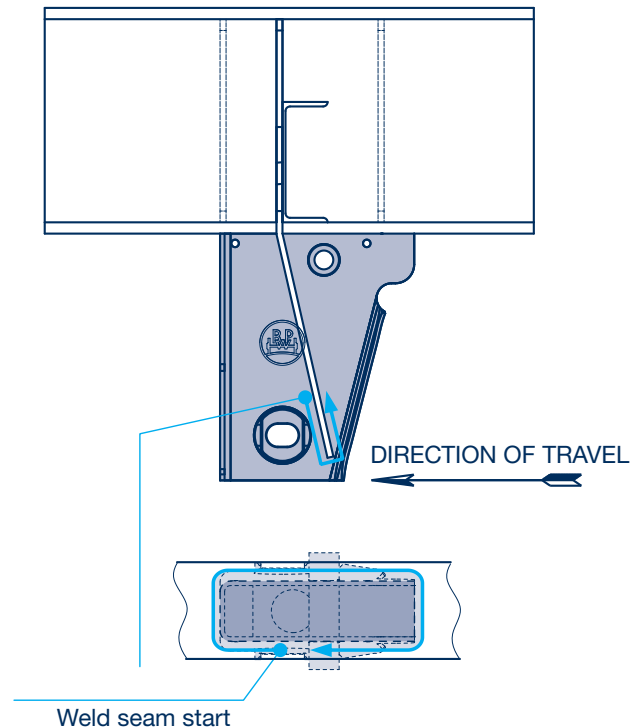

Airlight II - and SL steel hanger brackets / Airlight II channel crossmembers

- Gas shielded arc welding
Weld wire quality G 4 Si 1 – EN ISO 14341-A
- Manual arc welding
Stick electrodes E 46 5 B 32 H 5 – EN ISO 2560-A
- Mechanical quality values must correspond to the basic material S 420 or S 355 J 2
- Seam thickness acc. to DIN EN ISO 5817
 - Hanger bracket sheet thickness 6 mm -> a4 Δ
 - Hanger bracket sheet thickness 8 mm -> a6 Δ

Airlight II - stainless steel hanger brackets

- Gas shielded arc welding
Weld wire quality G 19 9 L Si (EN ISO 14343)
- Manual arc welding
Stick electrodes E 19 9 L R 32 (DIN EN ISO 3581)
- Mechanical quality values must meet the basic material X5CrNi18-10 or X6CrNi-Ti18-10 Seam thickness a4 Δ (DIN EN ISO 5817 Evaluation group C)
- Tempering colours must be removed for the purpose of warranty on the resistance to corrosion

Airlight II - aluminium hanger brackets

- MIG or WIG welding
Identical additional material Al Mg 4.5 Mn
- Clean thoroughly before welding
- Recommendation: Preheat to approx. ca. 60 – 80°C
- Seam thickness a8 Δ (DIN EN ISO 10042)



The general state-of-the-art regulations must be complied with when welding.

- Avoid end craters and undercuts.
- Functional surfaces are free from weld spatter.
- For all welding operations, the trailing arms, U-bolts, air bags, pipings and shock absorbers must be protected against flying sparks and weld spatter.
- The earth terminal must under no circumstances be attached to the trailing arm, U-bolt or hub.
- Use new spring bolts and lock nuts when replacing hanger brackets.
- It is not permitted to weld the trailing arms!
- It is not permitted for the hanger brackets to be heated for straightening work!

4.2.3 Installation and welding specifications of hanger brackets | Tack welding and track setting device

For the quick and precise positioning of hanger brackets and air bag plates, BPW offers a special device which can be used to fix the components onto the frame with a high degree of positional accuracy.

To do this, the vehicle frame of the trailer is first built with the underside facing upwards. The fixing device consists of a rigid, stable aluminium frame with clamping and positioning devices for various air suspension hanger brackets and air bag plates and is placed on the vehicle frame.

After the alignment to the kingpin using a laser, the device is clamped between the longitudinal beams.

Six air suspension hanger brackets and air bag plates are simultaneously placed on the frame for fixing through appropriate fitting holders.

Once the device is removed, the hanger brackets and air bag plates can be welded on.

The subsequent attachment of the air suspension unit will ideally enable the omission of the additional tracking process, since the axles are already in alignment with each other and with the kingpin through the defined position of the hanger brackets.

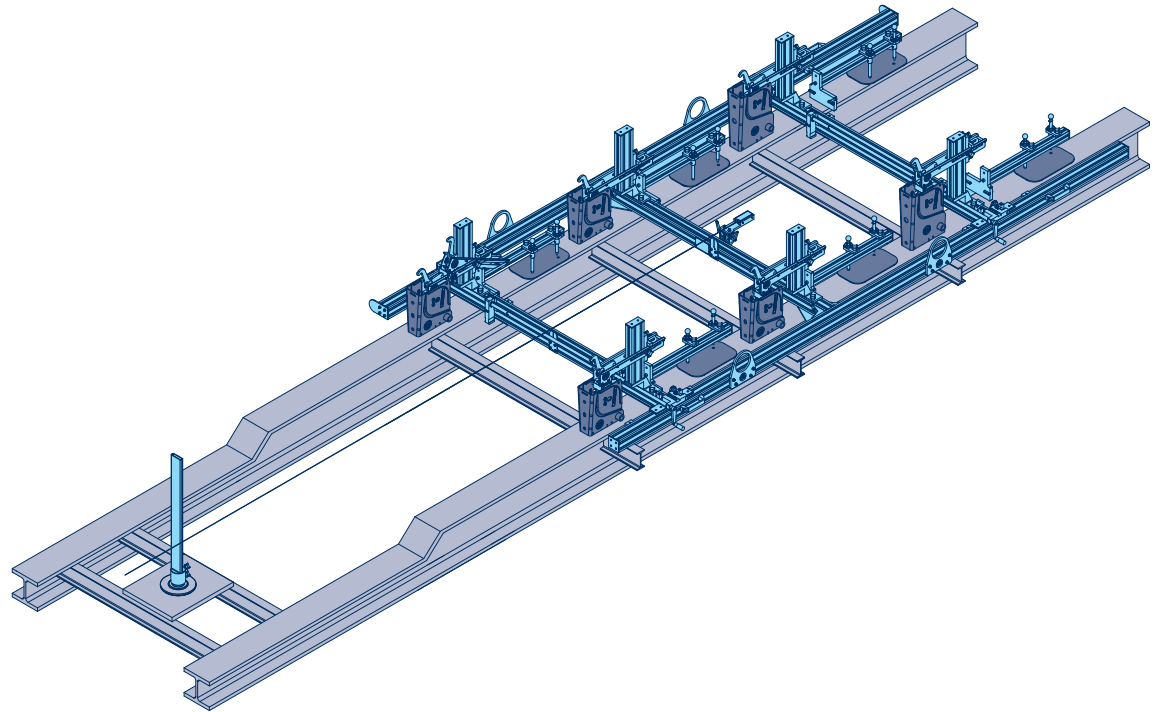

[Tack welding device in Youtube](#)

4.2.4 Hanger brackets, channel crossmembers, gusseting | Airlight II and SL steel hanger brackets (type V / EV)

It is easy to connect the smooth surfaces with the vehicle frame and weld on transverse gussets.

Together with the low hanger bracket height, the modular design provides extremely high torsional rigidity. Gussets can therefore be easily connected. (see page no. 197). The dimensions are given in the technical documents for each version and ride height.

Airlight II for single-leaf trailing arms (type V)

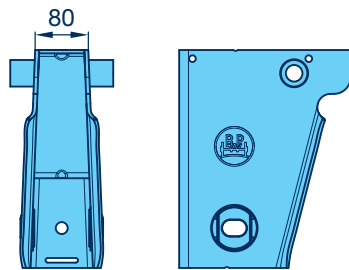

Airlight II for two-leaf trailing arms (type EV)

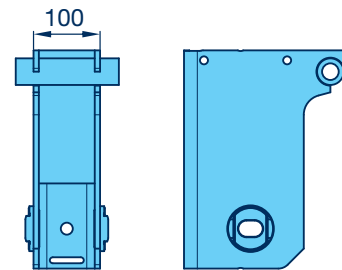

Airlight II steel hanger brackets characteristics

- for 70 mm wide trailing arms
- Spring bolts with M 24 thread
- Integrated adjusting comes as standard
- Axle load up to 12 t
- Top shock absorber attachment with screw and lock nut

SL rigid design (type E)

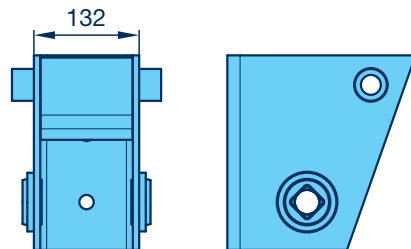

SL adjustable version (type EV)

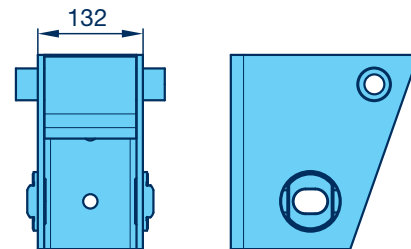

SL steel hanger brackets characteristics

- for 100 mm wide trailing arms
- Spring bolts with M 30 thread
- With or without adjusting
- Axle load up to 14 t (rigid hanger bracket)
- Axle load 12 t (rigid and adjustable hanger bracket)
- Top shock absorber attachment with screw and lock nut

4.2.4 Hanger brackets, channel crossmembers, gusseting | Airlight II hanger brackets Types K, X and AV

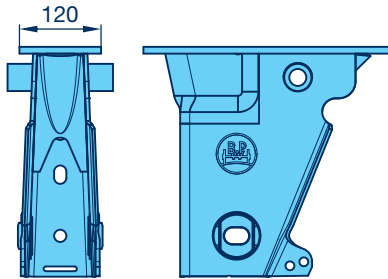

Bolt-on Airlight II steel hanger brackets (type K)

The bolted-on hanger bracket has a cover plate with 6 holes. The hanger bracket can be bolted on to the vehicle bottom flange (minimum width 120 mm) with a special knurled screw.

Together with the low hanger bracket height, the modular design provides extremely high torsional rigidity. Gussets can therefore be easily connected (*see page no. 197*).

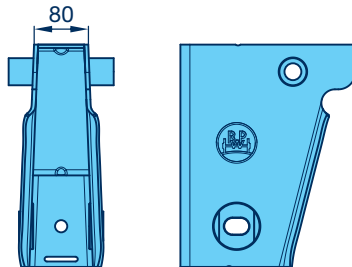

Airlight II stainless steel hanger brackets (type X)

The stainless steel hanger bracket is intended for use in vehicles with stainless steel frames.

It is designed so that it is possible to simply weld it to the stainless steel vehicle frame.

Together with the low hanger bracket height, the modular design provides extremely high torsional rigidity. Gussets can therefore be easily connected (*see page no. 197*).

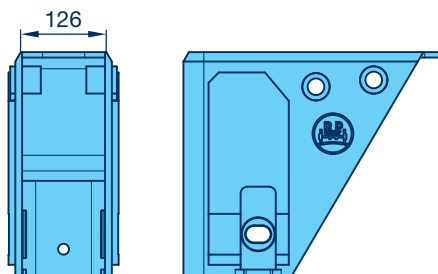

Airlight II aluminium hanger brackets (type AV)

The aluminium hanger bracket is intended for use in vehicles with aluminium frame.

It is designed so that it is possible to simply weld it to the aluminium vehicle frame.

The existing weld seam preparation and internal z sheet facilitate optimal installation. Description of the cross brace *see page no. 199*.

4.2.4 Hanger brackets, channel crossmembers, gusseting |

Characteristics Airlight II hanger brackets Types K, X and AV

Characteristics of Airlight II bolt-on steel / special steel / aluminium hanger brackets

- for 70 mm wide single-leaf trailing arms
- Spring bolts with M 24 thread
- Integrated adjustment comes as standard
- Axle load up to 9 t
- Top shock absorber attachment with screw and lock nut
- The dimensions are given in the technical documents for each version and ride height.

4.2.4 Hanger brackets, channel crossmembers, gusseting | Airlight II steel channel crossmember (type CV)

Weld-on steel channel crossmember (type CV)

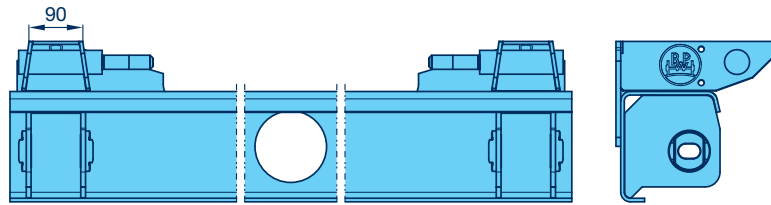

The open, narrow hanger brackets on the channel crossmember are 90 mm wide and can also be welded on to very narrow longbeam bottom flanges.

There are also bolt-on channel crossmembers with a welded-on cover plate available.

When using self-steering axles with trailing arms cranked on the side, shock absorbers can be attached to the channel crossmember.

The forces transferred from the wheels through the axles to the channel crossmember are absorbed by the items included in the BPW scope of delivery and guided into the chassis frame.

However, the bracing of the frame is not replaced as such by the channel crossmember.

Bolt-on steel channel crossmember (type CV)

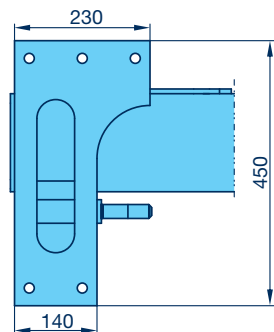
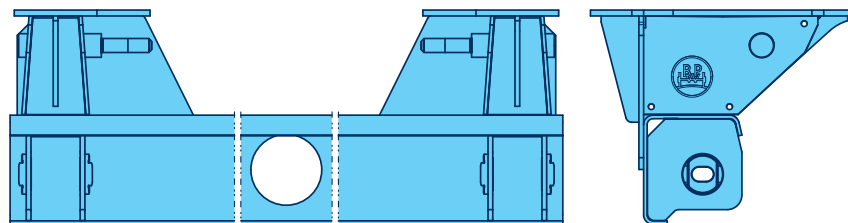

Airlight II channel crossmember characteristics

- for 70 mm wide single-leaf trailing arms
- Spring bolts with M 24 thread
- Integrated adjustment comes as standard
- Axle load up to 10 t
- Top shock absorber attachment on the threaded bolt or with screw and lock nut
- The dimensions are given in the technical documents for each version and ride height.

4.2.4 Hanger brackets, channel crossmembers, gusseting | Welded-on Airlight II and SL hanger brackets

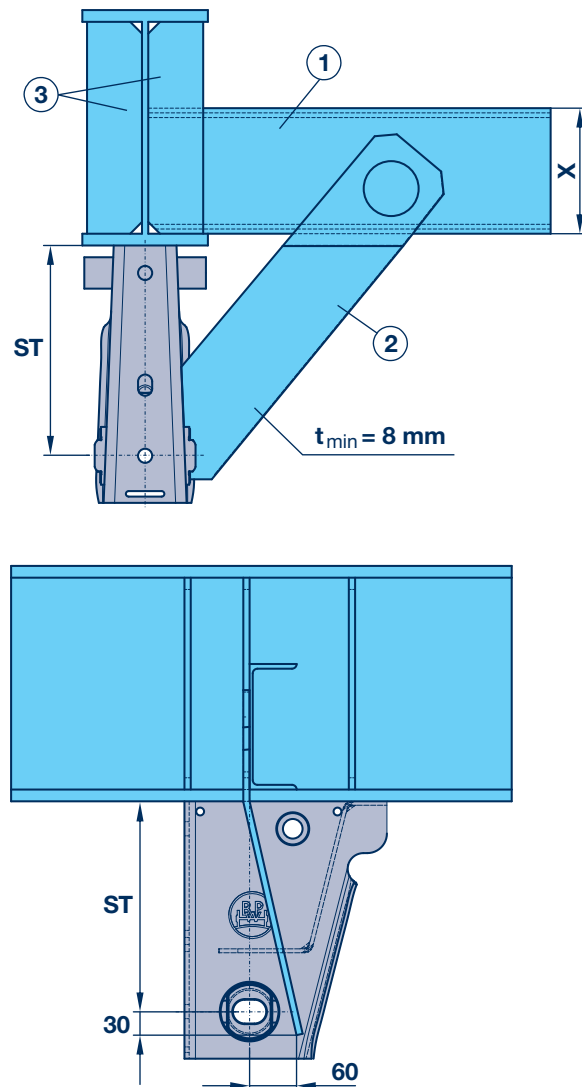

Example of a general bracing proposal with welded-on hanger brackets respectively gusset plates

With vehicle frames that are subject to torsion, a corresponding elastic and torsional brace on the hanger brackets is particularly necessary.

1. Crossmember

The forces created when travelling around bends are transmitted via the hanger brackets and gusset plates into the crossmember. This must be dimensioned accordingly. It has to be ensured that the correct connection to the longbeam is used. The connection of rigid-torsion, closed crossmember profiles to the soft-torsion dual-T longbeam must be designed with extra care as there is a risk of cracking due to stiffness discontinuity.

2. Gusset plates

The lateral forces are transmitted via the gusset plates as tensile resp. compressive loads to the crossmember.

The gusset plate has to be connected at the inner side of the hanger bracket, behind the spring bolt, to optimally stiffen the hanger bracket, which is open at the rear. The gusset plate should reach 30 mm lower than the centre of the spring bolt. It is recommended to attach the gusset plate to the frame in the centre to the spring bolt.

3. Vertical profiles

Suitable vertical profiles and ribs must be planned to stiffen the vehicle frame.

4.2.4 Hanger brackets, channel crossmembers, gusseting | Welded-on Airlight II channel crossmembers

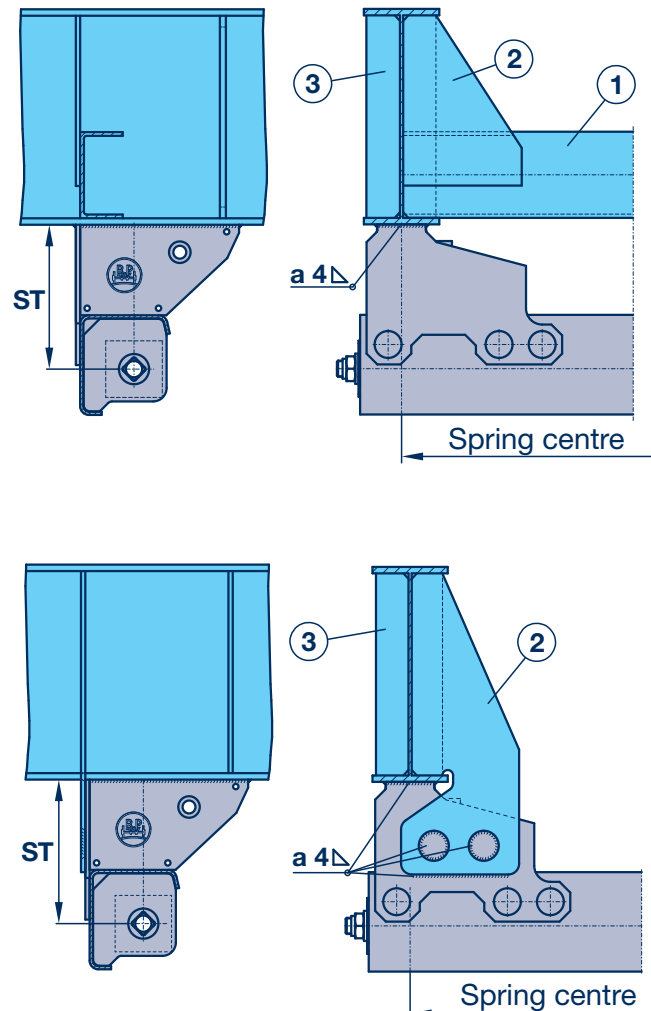

Example of a general bracing proposal to vehicle frames with channel crossmembers

With vehicle frames that are subject to torsion, a corresponding elastic and torsional brace on the channel crossmembers is necessary. An additional chassis crossmember is not in all cases necessary, when using the proposed bracing.

1. Crossmember

The forces created when driving through bends, for example, are absorbed within the channel crossmember group. Therefore, it has to have adequate dimensions. It has to be ensured that the correct connection to the longbeam is used. The connection of rigid-torsion, closed crossmember profiles to the soft-torsion dual-T longbeam must be designed with extra care as there is a risk of cracking due to stiffness discontinuity.

2. Gusset plates

The lateral forces and chassis frame deformation created when travelling around bends are transmitted through the gusset plates into the channel crossmember group. To ensure a good connection to the chassis frame, the gusset plate should connect the upper flange as well as the bottom flange of the longbeam. It should ideally be connected to the front of the channel crossmember with plug welding seams.

3. Vertical profiles

Suitable vertical profiles and ribs must be foreseen to stiffen the vehicle frame.

4.2.4 Hanger brackets, channel crossmembers, gusseting | Welded-on Airlight II aluminium hanger brackets

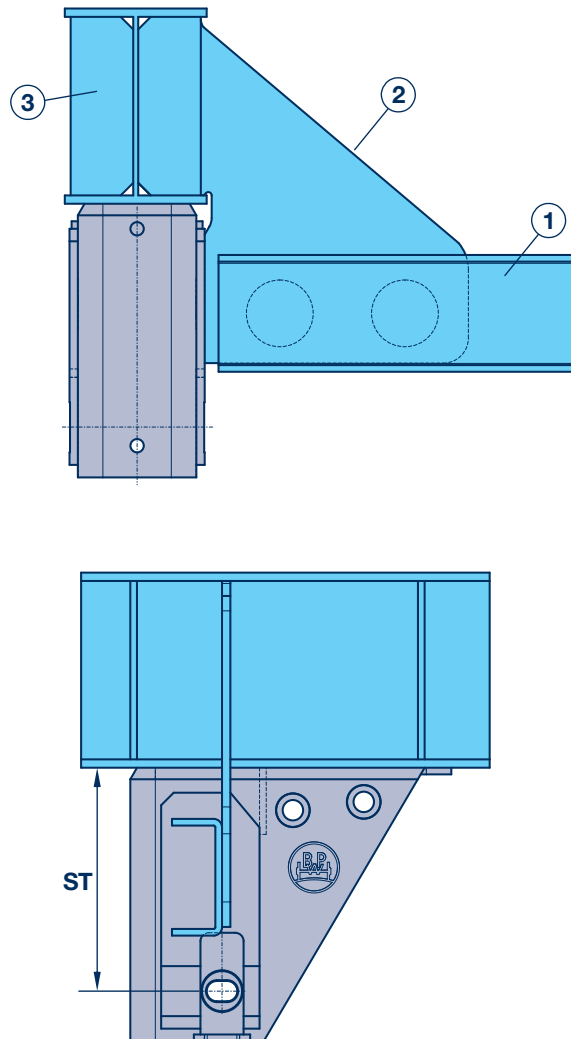

Example of a general bracing proposal for vehicles with aluminium hanger brackets

With vehicle frames that are subject to torsion, a corresponding elastic and torsional brace of the aluminium hanger bracket is particularly necessary.

1. Crossmember

The forces created when travelling around bends are transmitted via the hanger brackets and gusset plates into the crossmember. This must be dimensioned accordingly. It has to be ensured that the correct connection to the longbeam is used. The connection of rigid-torsion, closed crossmember profiles to the soft-torsion dual-T longbeam must be designed with extra care as there is a risk of cracking due to stiffness discontinuity.

2. Gusset plates

The lateral forces and frame deformation created when travelling around bends are transmitted through the gusset plates into the crossmember.

The crossmembers should ideally be attached by plug welding seams.

3. Vertical profiles

Suitable vertical profiles and ribs must be foreseen to stiffen the vehicle frame.

4.2.4 Hanger brackets, channel crossmembers, gusseting |

Welded-on, stiff connection Airlight II and SL hanger brackets

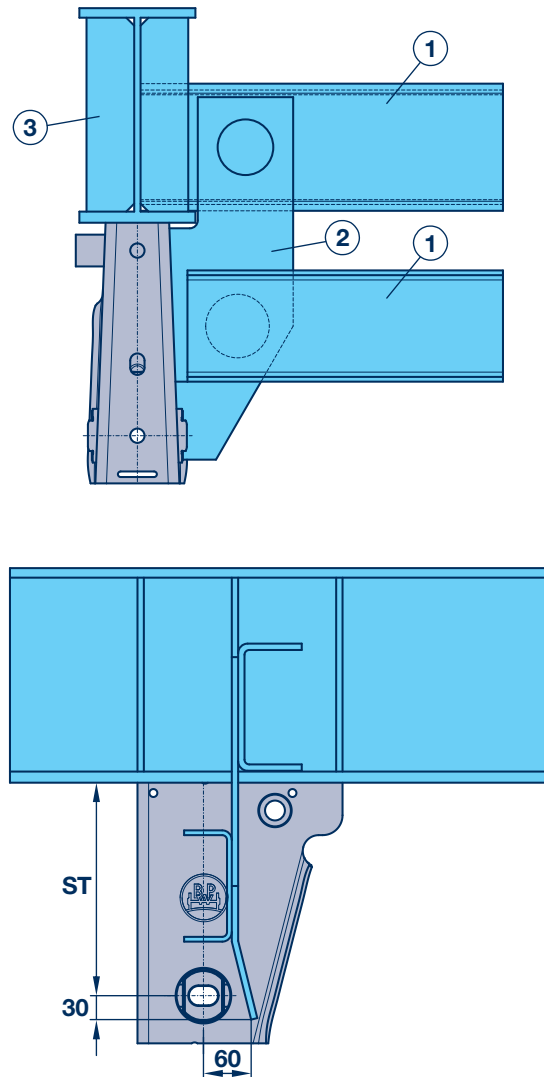

Example of a general bracing proposal for in longitudinal direction torsionally stiff vehicle frames (tankers, silos, box-body trailers) and for especially tough use.

With vehicle frames that are not subject to torsion, a corresponding rigid brace can be used for the hanger brackets via two crossmembers.

1. Crossmember

The forces created when travelling around bends are transmitted through the hanger brackets and gusset plates into the crossmembers. They must be dimensioned accordingly. It has to be ensured that the correct connection to the longbeam is used.

2. Gusset plates

The gusset plates transfer the lateral forces as tensile or compressive loads to the crossmember.

The gusset plate has to be connected at the inner side of the hanger bracket, behind the spring bolt, to optimally stiffen the hanger bracket, which is open at the rear. The gusset plate should reach 30 mm lower than the centre of the spring bolt.

3. Vertical profiles

Suitable vertical profiles and ribs must be foreseen to stiffen the vehicle frame.

4.2.4 Hanger brackets, channel crossmembers, gusseting | Bolted-on Airlight II hanger brackets and gusset plates

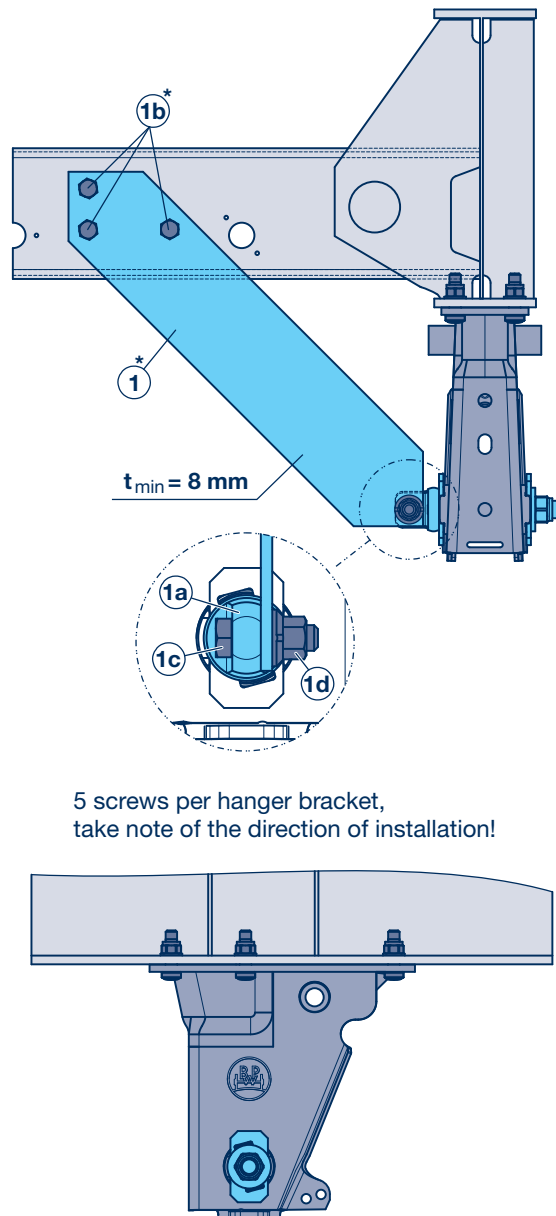

5 screws per hanger bracket,
take note of the direction of installation!

Example of a general bracing proposal with bolt-on hanger brackets and gusset plates.

With the bolted-on Airlight II hanger bracket, BPW is offering the opportunity of prefabricating compact vehicle frames without hanger brackets, coating them but not attaching the axle and suspension unit until the final assembly stage. The final design is only determined during the installation of the axle and suspension unit. The bolt-on system therefore provides vehicle manufacturers with logistics advantages and increases production flexibility.

1. Gusset plate screw connections

The bottom end of the gusset plate (1) is bolted onto the spring bolt (1a) directly using an M 18 connection bolt with nut (1c), (1d) which therefore permits direct force input. The spring bolt itself is a special bolt with flange. The flange simultaneously serves as a torsion protection.

The top end of the gusset plate is bolted onto the crossmember of the chassis frame using at least three M 16 10.9 bolts (1b). The bore holes in the components must have the following diameters:

Bore hole in the crossmember: \varnothing 16 mm
Bore hole in the gusset plate: \varnothing 18 mm

2. Hanger bracket screw connections

The air suspension hanger brackets are attached to the vehicle frame with 5 knurled screws each (take note of the direction of installation!).

The knurling of the screws serves as torsion protection. The special screw also has a flat head so that it can be installed directly next to the hanger bracket. The maximum unevenness of the longbeam is permitted to be 1 mm in the hanger bracket area.

As the torsion protection of the screwed joint is created by the spring bolt flange, the bolt must always be attached to the vehicle frame through a gusset plate.

A bolt-on crossmember between the spring bolts is impermissible without a connection to the frame!

With vehicle frames that are subject to torsion, a corresponding elastic and torsional brace on the hanger brackets is particularly necessary.

4.2.4 Hanger brackets, channel crossmembers, gusseting |

Bolted-on Airlight II hanger brackets and gusset plates

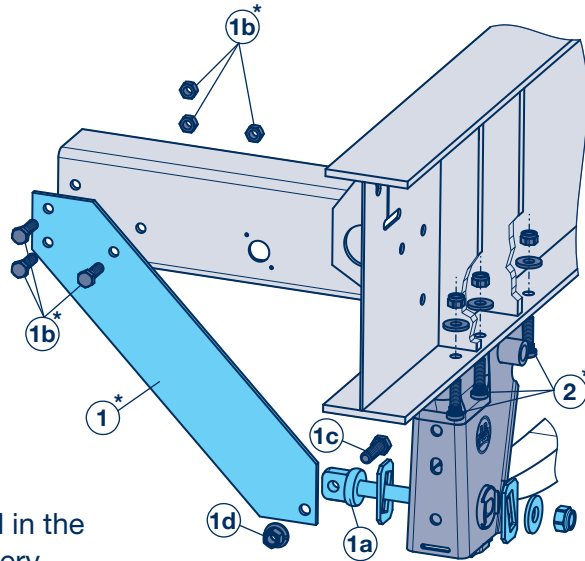

* Not included in the scope of delivery

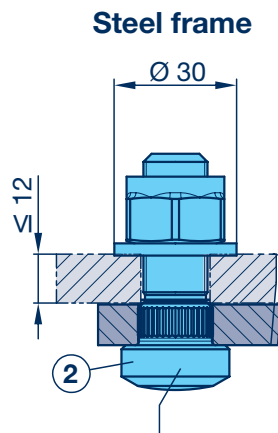

Knurled screw M 16, connection frame / hanger bracket

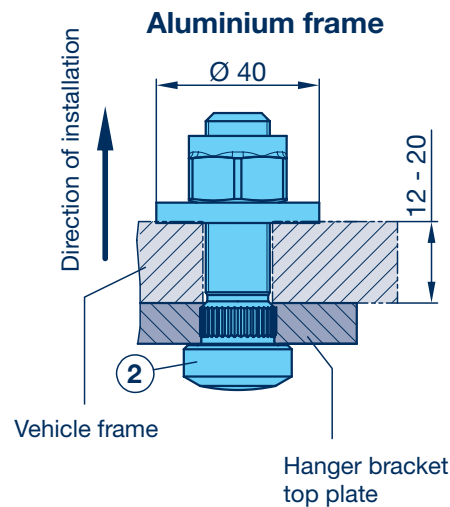

Installation process for bolt-on hanger brackets

1. Bolt hanger bracket M 16 (2) on to vehicle frame. Tightening torque: 260 Nm (240 - 285 Nm).
2. Loosely pre-mount spring bolt (1a).
3. Pre-mount gusset plates (1) with min. three screws M 16, 10.9 (1b) (top) and screw M 18 (1c) (bottom). Pre-mount the corresponding nuts (1d).
4. Tighten the M 18 connecting bolt (1c) to approx. 50 Nm.
5. Tighten the M 24 spring bolt (1a) loosely until all components have been brought into contact.
6. Adjust the track, [see chapter 2.8](#).
7. Tighten M 24 spring bolt (1a). Tightening torque: 650 Nm (605 - 715 Nm). Do not use an impact wrench!
8. Tighten the M 18 connecting bolt (1c) (gusset plate-spring bolt). Tightening torque: 420 Nm (390 - 460 Nm)
9. Tighten the top connecting bolts M 16, 10.9 (1b) (gusset plate / cross-member) to the max. permitted tightening torque (not supplied by BPW).

Tightening torques [see chapter 4.2.13](#).

4.2.5 Trailing arm and spring bolt bearing | Trailing arm versions

BPW has a large selection of trailing arms in its air suspension programmes. The combination with various hanger brackets, trailing arms, shock absorbers, air bags, brackets and axle lifts enables a variety of suspension units for the many different trailer designs that is unique in the industry. This enables precisely tailored solutions for ride height, pendulum and suspension travel, ground clearance and roll stability to be achieved for different axle loads - taking into account lightweight construction and maximum service life. The air suspension data sheets ([see chapter 1.2.4](#)) show the broad standard of this combination. In addition, BPW offers customised air suspension units that are tailored to the respective application.

Trailing arm, Serie **ALO / ALU**

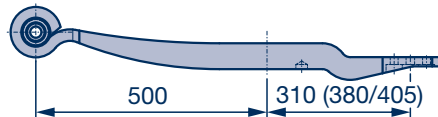

Hollow profile trailing arm LightTube, Serie **ALO / ALU**

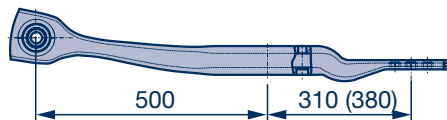

Trailing arm, Serie **ALM**

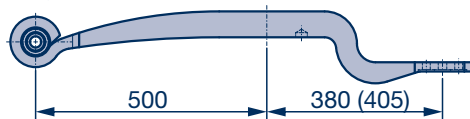

Hollow profile trailing arm LightTube, Serie **ALM**

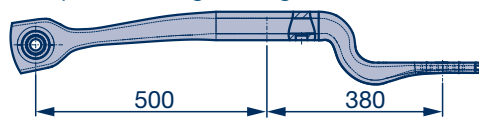

Trailing arm, Serie **ALMT** for very low ride heights with long suspension travel

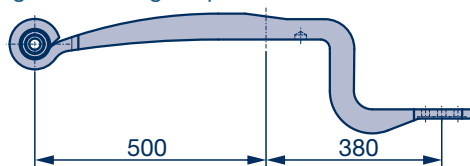

Trailing arm, Serie **ALM** long stroke

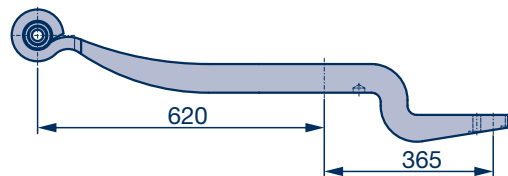

Trailing arm, series **ALUW** for optimised position of brake cylinder and axle lift

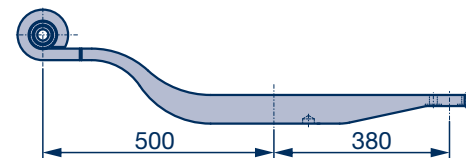

Double leaf trailing arm, Serie **ALU**

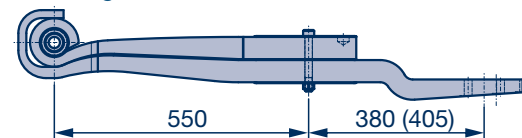

Double leaf trailing arm, Serie **ALU** long stroke

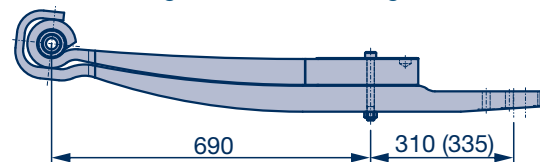

The illustrations show examples of various trailing arms from the AL II programme. They are mostly used in single-leaf design.

However, double-leaf trailing arms are also available for special requirements, e.g. long-travel suspension arms. It should be noted that the roll stiffness of the double-leaf trailing arms is lower, but the load capacity and service life is higher than that of single-leaf trailing arms designed for the same axle load.

The hollow profile LightTube reduces the chassis weight by 14 kg per axle.

Trailing arm 3D, Serie **ALM** with lateral offset for self-steering axles

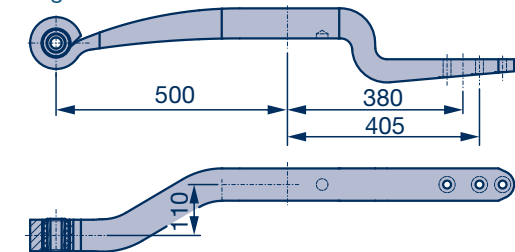

Optimized installation in the unit [see chapter 2.4.8](#).

4.2.5 Trailing arm and spring bolt bearing |

AL II (M 24) and SL air suspension (M 30) hanger brackets and channel crossmembers

Spring bolt bearing, rigid

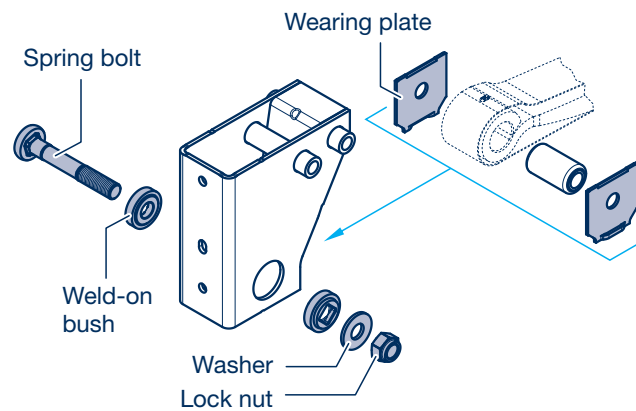

With BPW hanger brackets, the head of the spring bolt is secured from rotating by means of a profiled lot.

The spring bolts should be mounted from the outside (wheel side) towards the inside (from the inside to the outside for bolted-on gusset plates).

The rigid spring bolt bearing is only available with SL air suspension.

Spring bolt bearing, adjustable

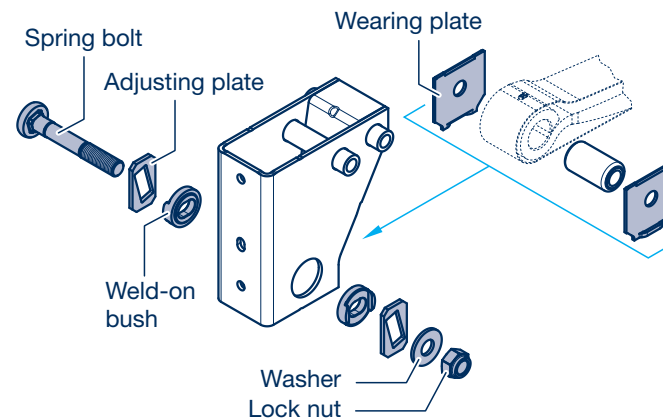

Make sure the inner and outer adjusting plates of adjustable hanger bracket are adjusted symmetrically. Ensure that the correct wearing plates are used (see right).

Before tightening the lock nut, the axle position must be set to ride height to prevent impermissible distortion of the rubber bush.

Tightening torque *see chapter 4.2.13*.

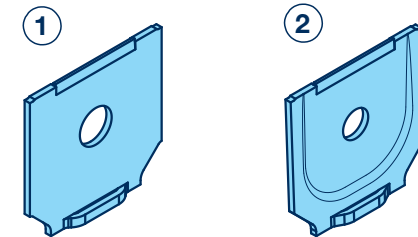

BPW uses two different versions of wearing plates.

1. A straight shaped plate for straight air suspension hanger brackets and channel crossmembers
2. An offset shaped plate for angled air suspension hanger brackets (narrow at top).

4.2.5 Trailing arm and spring bolt bearing | Airlight II (M 24) adjustable aluminium hanger brackets

Aluminium hanger bracket, side shock absorber attachment

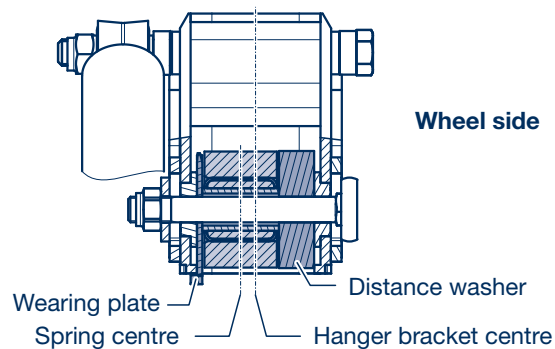
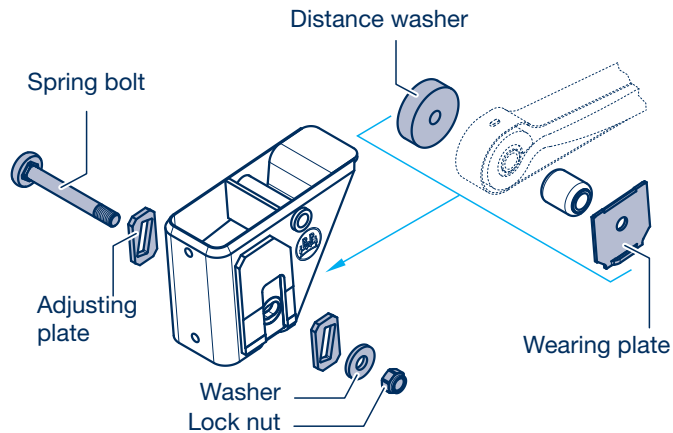

With BPW air suspension axles with adjustable aluminium hanger brackets, the head of the spring bolt is secured from rotating by means of a profiled lot in the adjusting plate.

The spring bolt should be mounted from the outside (wheel side) towards the inside.

A distance washer is placed between the rubber bush and steel bush of the aluminium hanger bracket on the wheel side instead of a wearing plate when installing shock absorbers from the side.

A straight wearing plate must be used on the inside.

Make sure the inner and outer adjusting plates on each hanger bracket are adjusted symmetrically.

Before tightening the lock nut, the axle position must be set to ride height to prevent impermissible distortion of the rubber bush.

Tightening torque *see chapter 4.2.13.*

In asymmetrical designs, the centre of the hanger bracket is 30 mm bigger than the spring centre.

Aluminium hanger bracket, central shock absorber attachment

If the shock absorber is positioned in the centre on the spring or if there is no shock absorber fastening in the hanger bracket, two round wearing plates are used.

Make sure the inner and outer adjusting plates on each hanger bracket are adjusted symmetrically.

Before tightening the lock nut, the axle position must be set to ride height to prevent impermissible distortion of the rubber bush.

Tightening torque *see chapter 4.2.13.*

The hanger bracket centre is identical to the spring centre in the symmetrical design.

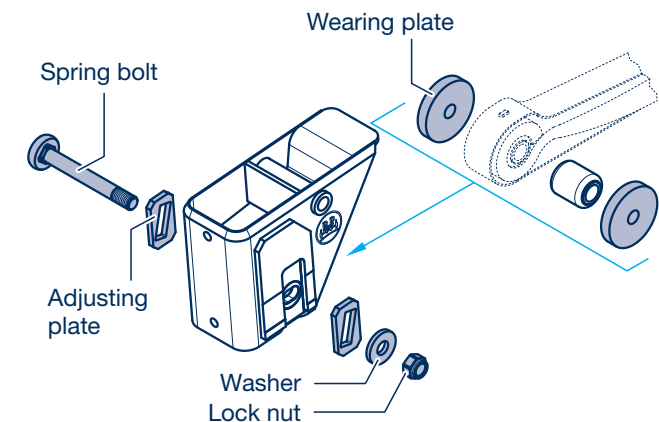

4.2.6 Axle beam welding and connection | Axle beam welding guidelines

Material: S 420 and S 355 J 2

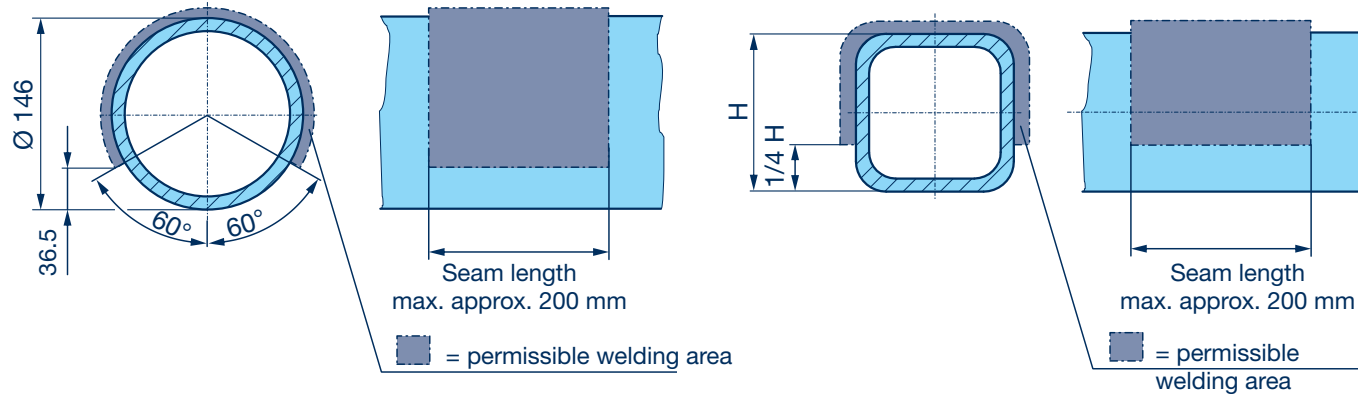

General

When installing trailer axles, it may be necessary to subsequently weld components on to the axle beam (e.g. support for central axle lift).

BPW axles are made of materials that can be welded. The axle beams do not have to be pre-heated before welding.

The carrying capacity and faultless operation of BPW axles are not impaired by welding, if the following points are complied with.

Welding process

- Gas shielded arc welding
Weld wire quality G 4 Si 1 – EN ISO 14341-A
- Manual arc welding
Stick electrodes E 46 5 B 32 H 5 – EN ISO 2560-A
- Mechanical quality values must correspond to the basic material S 420 or S 355 J 2
- Weld thickness a 5 ▽
(DIN EN ISO 5817 Evaluation group C)
- Avoid end craters and undercuts!
- Functional surfaces are free from weld spatter



Weld seams must not create impermissible changes in the camber and side directions of the axle. The welding areas and seam lengths (see drawing) must therefore be complied with at all times.

Do not weld in the lower area of the axle beam (bottom)!

For all welding operations, the trailing arms, spring U-bolts, air bags, plastic lines and shock absorbers must be protected against flying sparks and weld spatter.

The earth terminal should under no circumstances be attached to the trailing arm, spring U-bolt or hub.

It is not permitted to weld the trailing arms!

4.2.6 Axle beam welding and connection | Airlight II and SL air suspension

Welded axle connection (Airlight II and SL air suspension)

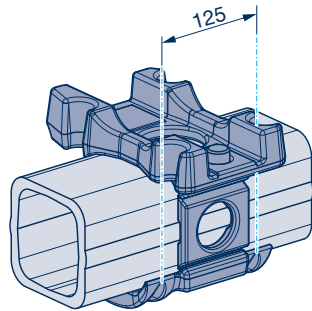

The welded Airlight II axle connection contains the spring U-bolt M 24 (SW 36).

In case of welded axle connection, the screwed joints have to be regularly checked and tightened, if necessary.

Clamped axle connection (Airlight II)

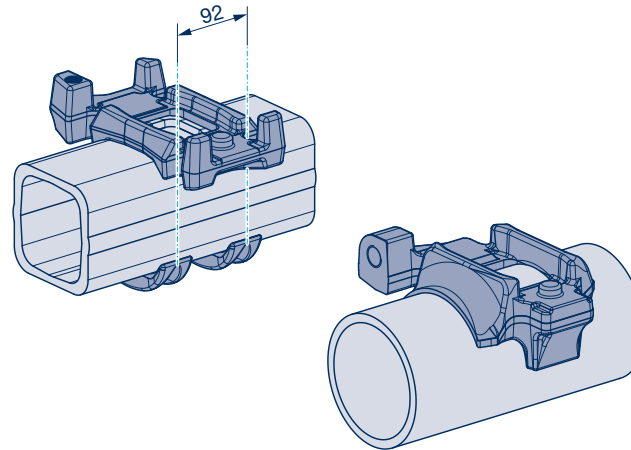

This Airlight II axle connection with spring U-bolt diameter M 22 (32 mm) is tightened with a torque and angle process controlled by the tensile yield strength. This has the advantage that the Airlight II air suspension is maintenance-free in on-road applications.

The axle connection therefore must not be uninstalled so as not to invalidate the warranty!

In Airlight II air suspension systems with clamped axle connection, the screwed joints have to be checked regularly and retightened if necessary because of the high loads when used under off-road conditions.

The tight seat of the spring U-bolt screw joints for the clamped and welded axle connection must be checked at the specified intervals.

For more information about the maintenance intervals, please refer to the maintenance regulations or workshop manuals.

The specified tightening torques ([see chapter 4.2.13](#)) must be complied with at all times to prevent damage to the components.

4.2.7 Air bags | General

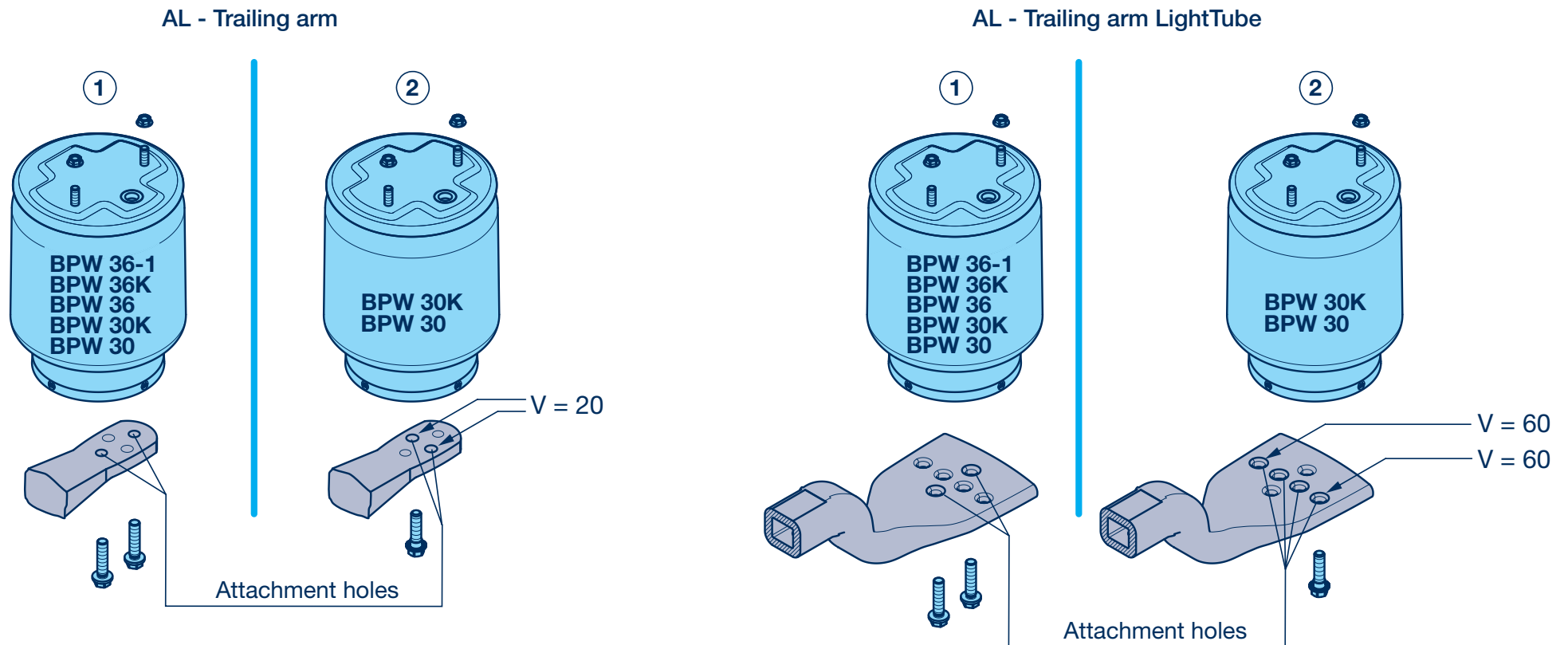

General

The top air bag plate is attached to the vehicle frame through the screwed joint of the 2 stud bolts (M 12).

Type 30 bags are operated at a higher pressure than type 36 bags. The quicker power build-up is achieved thanks to the lower pressure in the type 36 bags. They are therefore particularly suitable for applications where it is important to lift or lower the vehicle quickly. Type 36 bags also have a bigger power reserve for greater lifting heights.

4.2.7 Air bags | General

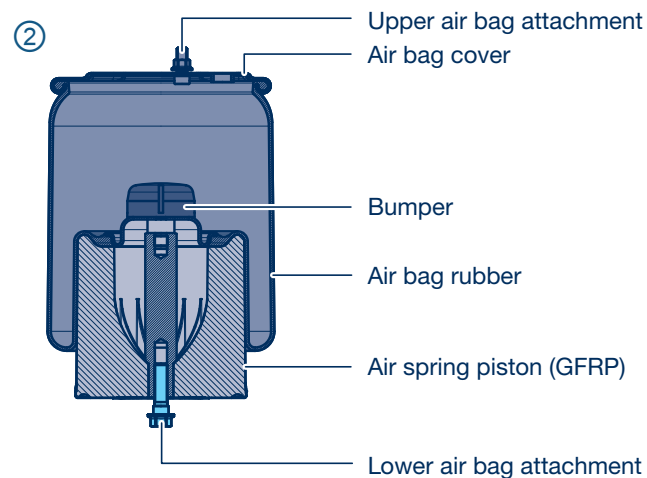
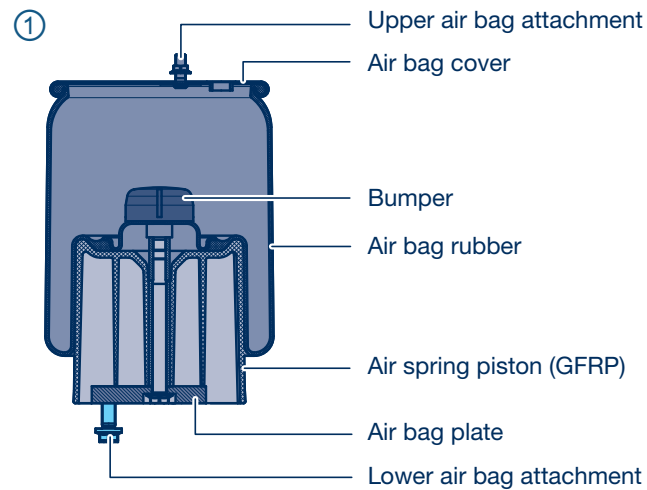

2 variants of air bags are used for BPW Airlight II and SL air suspension kits.

① Air bag with bolted air bag plate in the air spring piston

The air bag is connected to the trailing arm by two fastening screws. The following offset dimensions are achieved by the mounting plate:

- 0 / 20 / 60 mm with air bag Ø 300
- 45 / 80 mm with air bag Ø 360 (square air bag plate)
- 0, 32, 55, 90 mm special offset for air bags Ø 360
- 45 / 80 mm with air bag Ø 360 in HD use: Variant with round bellows plate, which completely closes off the air bag at the bottom
- When using LightTube with bellows Ø 360, the following offsets are possible: 0, 32, 45, 55

② Air bag with central bolt (Ø 300)

The air bag is connected with the trailing arm with a fixing screw. Offset dimensions of 20 mm are achieved through the holes in the trailing arm (with LightTube additionally 60 mm).

Tightening torques [see chapter 4.2.13](#).

4.2.7 Air bags | Versions

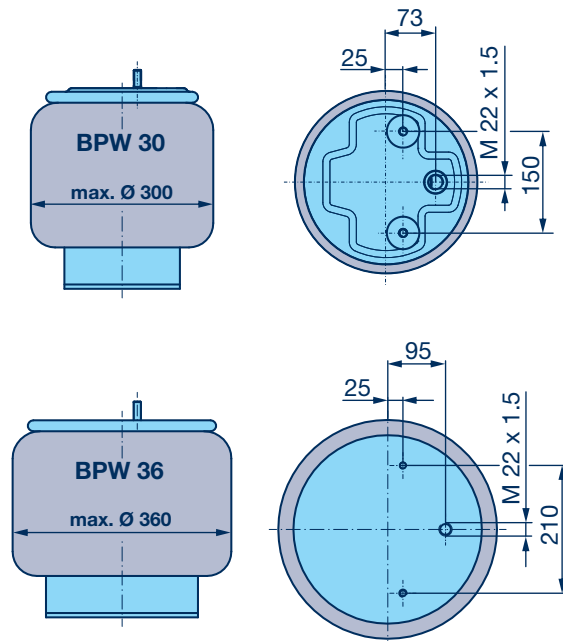

The various bag lengths (K, Standard, -1) result in various spring deflections and lifting heights (e.g. 190 mm, 220 mm, 260 mm at axle centre). Greater spring deflections are generally more suitable for off-road use to ensure the required axle load equalization.

Air bag BPW 30

- BPW 30 for 220 mm spring deflection at axle centre
- BPW 30 K for 190 mm spring deflection at axle centre
- (both spring deflections based on trailing arm L1 = 500 mm, L2 = 380 mm)
- Diameter max. 300 mm at approx. 5 bar
- specific air bag pressure 0.00023 bar/N (at ride height)
- Air bag offset V = 0, 20, 60 mm with air bag with bottom air bag plate (t = 20 mm)
- Air bag offset V = 20 mm with air bag with central bolt

Air bag BPW 36

- BPW 36 for 220 mm spring deflection at axle centre
- BPW 36 K for 190 mm spring deflection at axle centre
- BPW 36-1 (Long stroke version) for 260 mm spring deflection at axle centre
- (all spring deflections based on trailing arm L1 = 500 mm, L2 = 380 mm)
- Diameter max. 360 mm at approx. 3.5 bar
- specific air bag pressure 0.000156 bar/N (at ride height)
- Air bag offset V = 80, bottom air bag plate with t = 14 mm
- Air bag offset V = 45 / 80 (0, 32, 55, 90), reinforced bottom air bag plate with t = 20 mm
- Air bag offset V = 45 / 80 with lower, round air bag plate HD with t = 20 mm

4.2.7 Air bags | Assembly

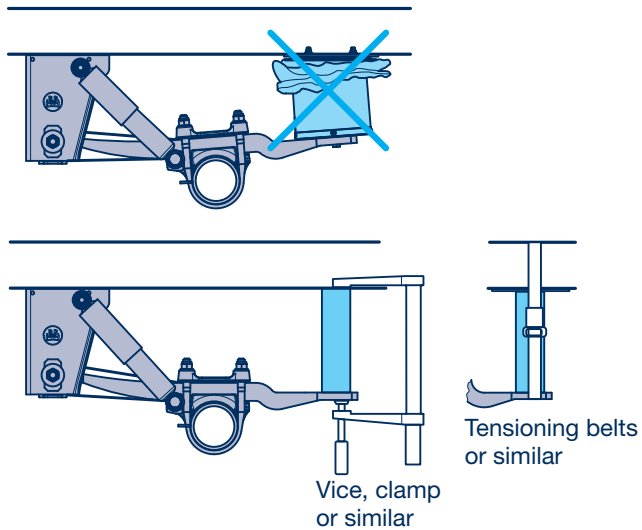

The rubber roll-up bag is a delicate component and must be protected against damage during the vehicle production process, just like the tyres.

The air bag should always be installed with the rubber rolled up. The rubber must not crease as the folds leave a permanent mark and will influence the unrolling behaviour and life expectancy at a later date.

If the semi-finished vehicle or chassis is moved on its own axle for purposes such as paint application, for instance, it is recommended to install a strut as an air bag replacement. By doing so, the air bag also does not have to be covered to protect it against the paint and is only installed during the final assembly stage.

4.2.7 Air bags | Air bag with offset

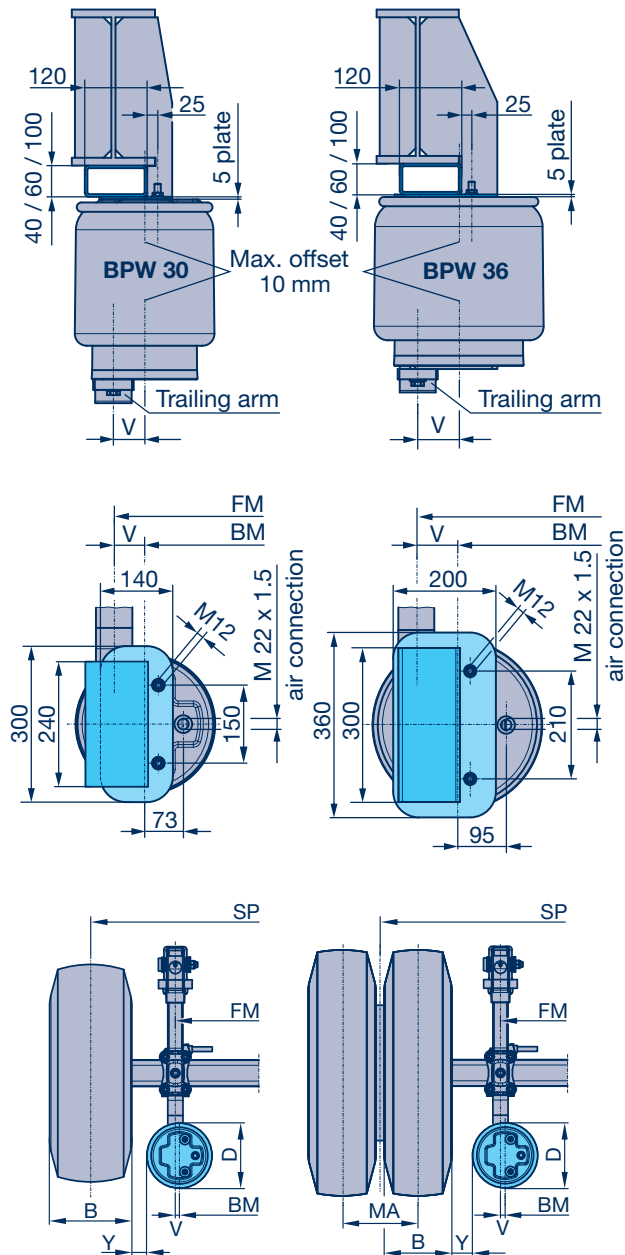

General

The transmission of force between the air bag and vehicle frame must be ensured with a suitable design. Particularly when installing components with an offset to the side, the bending moment which occurs must be absorbed with ribs and gusset plates or even crossmembers. The air bag force calculation is described in [chapter 4.2.2](#).

The "loaded without air" load case must also be taken into consideration, if necessary. In special situations (e.g. loading a semi-trailer onto a ferry or unloading a rear tipper), the axle load portion which then must be supported through the air bag bumper can significantly exceed the static value.

During installation, the air bag centre at the top (on the vehicle frame) must not deviate by more than 10 mm from the air bag centre at the bottom (on the axle side). The air bag must not be installed with a twist between the top and bottom air bag attachment.

Example of installation and reinforcement with packer

In this case, an air bag plate with the following minimum dimensions must be planned in addition to the square tube and rib:

Air bag BPW 30: 300 mm x 140 mm
Air bag BPW 36: 360 mm x 200 mm

Example of installation and reinforcement without packer

In this case, the air bag plates also have to be planned with the minimum dimensions stated above.

Clearance between air bag and tyre

The min. clearance between the air bag and tyre should be 30 mm and can be calculated as follows:

$$Y = 0.5 \times (SP - FM - B - D - MA) + V$$

SP = Track width
FM = Spring centre
D = Air bag diameter
V = Air bag offset
B = Tyre width
BM = Air bag center
MA = Tyre centre distance
(for single wheels = 0)

Clearance between air bag and brake cylinder (for drum brakes)

The min. clearance between the air bag and brake cylinder must be 30 mm.

Tightening torques [see chapter 4.2.13](#).

4.2.7 Air bags | Air bag in centre of frame

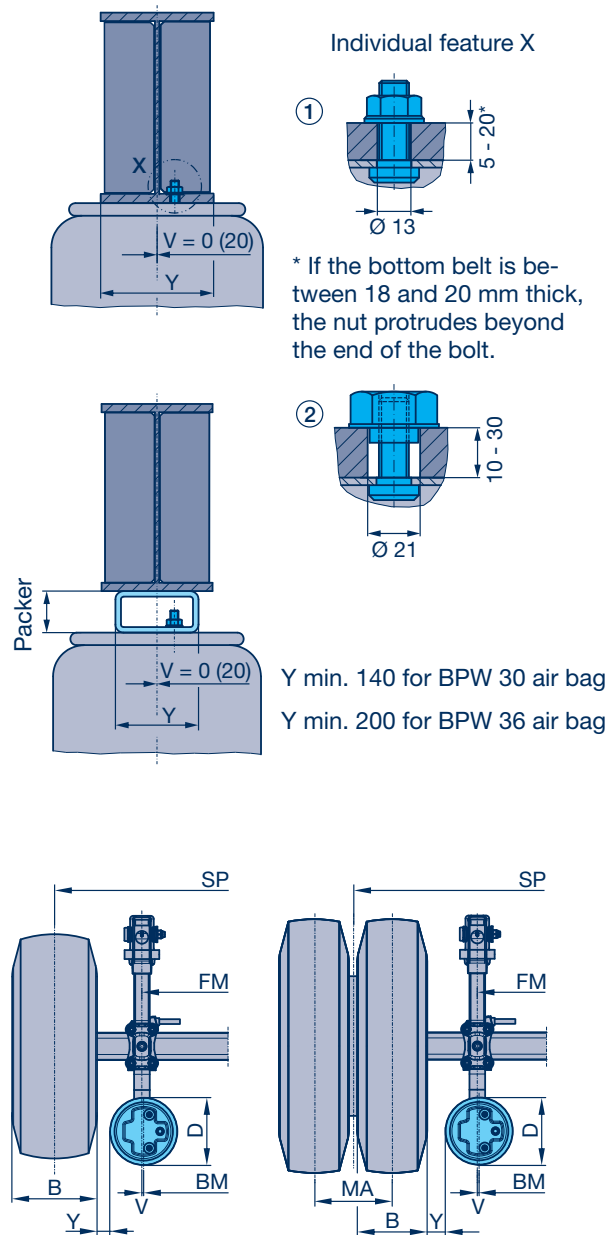

General

The transmission of force between the air bag and vehicle frame must be ensured with a suitable design. The air bag force calculation is described in [chapter 4.2.2](#). The "loaded without air" load case may also have to be taken into consideration, if necessary.

In special situations (e.g. loading a semi-trailer onto a ferry or unloading a rear tipper), the axle load portion which then must be supported through the air bag bumper can significantly exceed the static value.

During installation, the air bag centre at the top (on the vehicle frame) must not deviate by more than 10 mm from the air bag centre at the bottom (on the axle side). The air bag must not be installed with a twist between the top and bottom air bag attachment.

Example of installation and reinforcement with packer

When installing the air bag in the centre of the frame with little or no offset ($V = 0$ or 20 mm), holes may be drilled into the lower flange of the longbeam for inserting the upright bolt M 12. For bottom flanges with a thickness of 20 mm, shaft nuts with spring washers must be used and bore holes with 21 mm diameter.

Example of installation and reinforcement without packer

The minimum dimensions of the air bag support (plate or wide bottom flange) for the BPW 30 air bag must also be 140 mm x 300 mm in this case.

Clearance between air bag and tyre

The min. clearance between the air bag and tyre should be 30 mm and can be calculated as follows:

$$Y = 0.5 \times (SP - FM - B - D - MA) + V$$

SP	= Track width
FM	= Spring centre
D	= Air bag diameter
V	= Air bag offset
B	= Tyre width
BM	= Air bag center
MA	= Tyre centre distance (for single wheels = 0)

Clearance between air bag and brake cylinder (for drum brakes)

The min. clearance between the air bag and brake cylinder must be 30 mm.

4.2.7 Air bags | Air bag with split piston

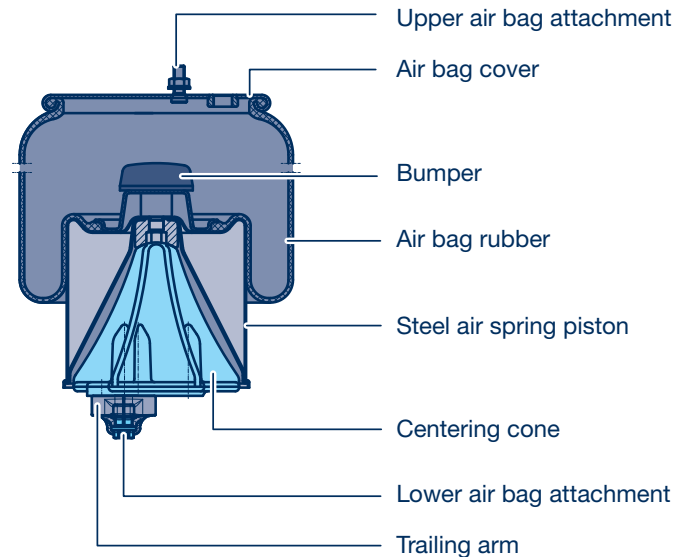

This design (Kombi-Airbag) provides unrestricted usability of vehicles with air suspension for combination traffic.

The air bag is split in two halves and consists of the central cone which is installed on the trailing arm and the roll-up bag with the piston.

If the vehicle is raised after the air is exhausted from the suspension, the axles move downwards through its own weight. The roll-up bag with the piston remains in its resting position and the trailing arm with the centering cone drops down.

The air suspension unit securely reconnects once the vehicle is lowered again. The air bags can neither fold nor crease.

This guarantees a long life expectancy.

When driving on road, there is no difference between the split piston air bag and a conventional BPW air suspension.

Split air bags are available as BPW 30 or BPW 30K.

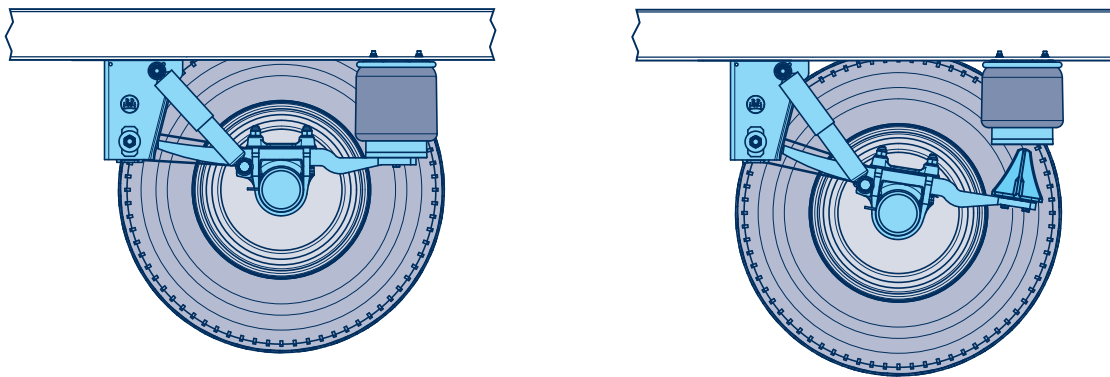

As the shock absorbers act as end stops in this design, it must be ensured that they are installed with a corresponding length. Please refer to the instructions on the air spring installation / raising and lowering ([see chapter 4.2.10](#)).

The corresponding series designs are listed in the EA data sheets (My BPW).

4.2.8 Shock absorbers

The purpose of shock absorbers is to rapidly reduce the vibrations occurring between the axle and body during driving.

This prevents any further yawing of the body and running gear components, and ensures that the tyres maintain optimum roadholding. The purpose of this roadholding is to ensure that the vehicle tracking remains accurate and that the vehicle brakes correctly.

BPW shock absorbers operate according to the twin tube principle. In the compression stage (corresponding to upward travel), the oil is pressed into the working space at the top, which then flows back into the working space at the bottom during the rebound travel (corresponding to downwards travel). The built-in valves produce the required damping characteristics (characteristics curve).

BPW recommends using HD dampers for use on rough road surfaces and for high off-road speeds.

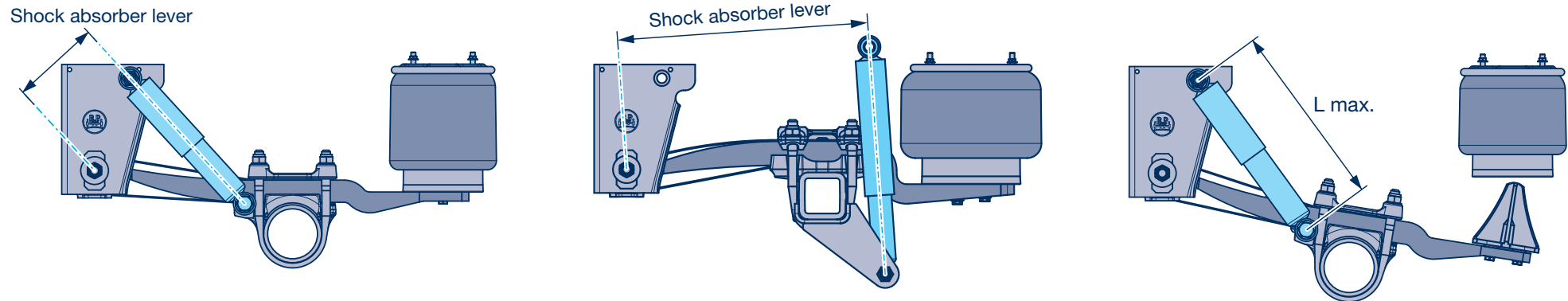

The effect depends on this characteristics curve as well as the lever around the spring bolt. The damping torque crucial for the dampening process results from the damping force and this lever.

Shock absorbers located at the rear with large stroke therefore have a bigger lever but flatter characteristics curve. The increase in damping torque with rising lever is non-linear as the damper speed, and therefore forces, increase as well. Overall, the damping effect of dampers located at the rear is higher.

BPW shock absorbers are matched to the vehicle, overall height, installation position and applications. For air suspensions with split bags (Kombi-Airbag), the shock absorbers also act as an end stop to prevent further lowering of the axles.

4.2.8 Shock absorbers

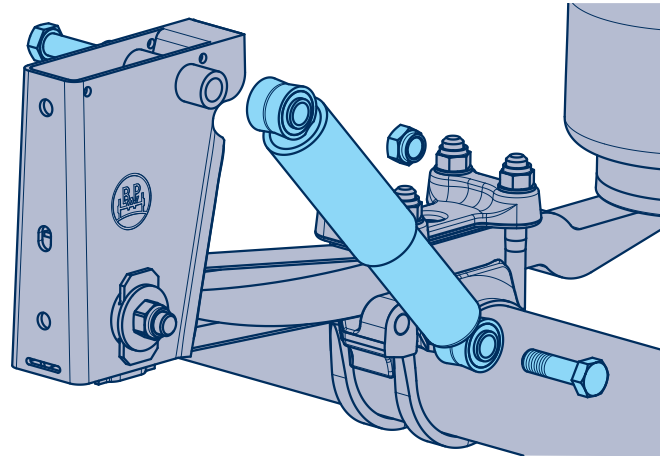

Location
at side

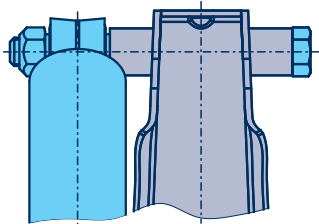

Central
location

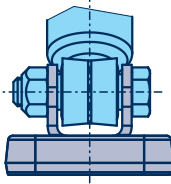
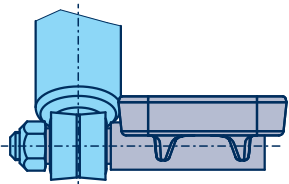
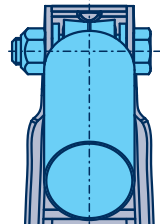

Shock absorbers may be arranged in different ways depending on the version:

- On the side next to the hanger bracket (towards the centre of the axle next to the trailing arms)
- Centrally in relation to the air suspension hanger brackets above the trailing arms

The shock absorbers are attached using M 24 screws or welded on threaded bolts with lock nuts.

Depending on the version, it may be necessary to use additional rings, washers and sleeves for installation.

Tightening torques *see chapter 4.2.13.*

4.2.8 Shock absorbers

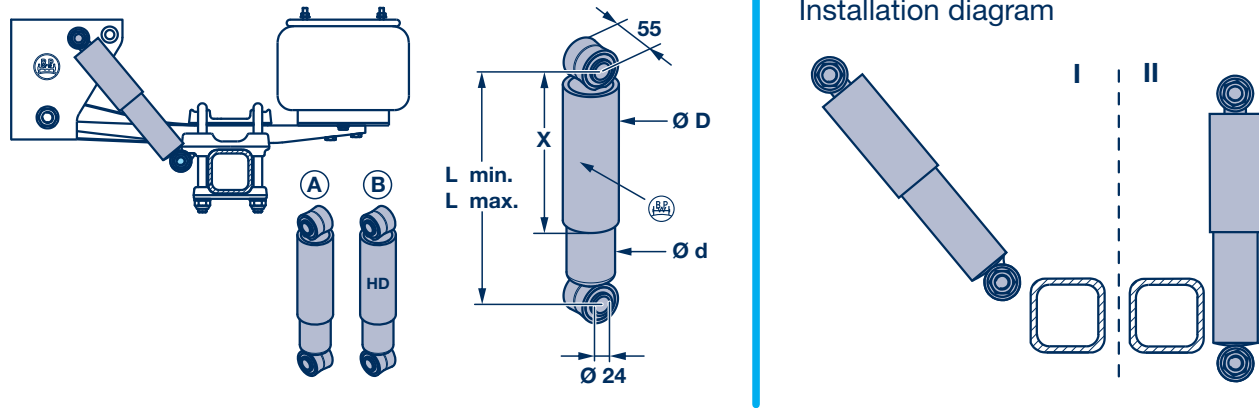

Installation diagram	BPW item number	Exec.	Dimension					N = Newton at 13 cm/s		N = Newton at 52 cm/s	
	Shock absorber with steel and rubber bushes Ø 24 / 32		L min.	L max.	X	D	d	\updownarrow N / \updownarrow N	\updownarrow N / \updownarrow N		
I	02.3722.79.02	A	287	412	204	75	65	13280 / 2930	15250 / 5010		
I	02.3732.05.02	B			195	74		6300 / 1740	17000 / 3000		
I	02.3722.89.02	A	292	432	204	75	65	13280 / 2930	15250 / 5010		
I	02.3732.07.02	B			195	74		6300 / 1740	17000 / 3000		
I	02.3722.04.02	A	326	496	235	75	65	6300 / 1740	17000 / 3000		
I	02.3722.83.02	A	326	496	235	75	65	13280 / 2930	15250 / 5010		
I	02.3722.88.02	A	351	541	250	75	65	13280 / 2930	15250 / 5010		
I	02.3732.06.02	B			255	74		6300 / 1740	17000 / 3000		
I	02.3702.20.02	A	426	696	325	82	72	8000 / 1290	16000 / 2150		
I II	02.3702.51.02	A	430	700	330	75	66	3800 / 500	8000 / 800		
II.	02.3702.67.02	A	466	766	380	75	60	3750 / 540	10500 / 1000		
I II	02.3702.60.02 ¹⁾	A	475	795	390	82	72	6300 / 1600	17000 / 3000		
II.	02.3702.18.02	A	475	800	390	82	72	4100 / 400	9000 / 900		
II.	02.3722.62.02	A	536	906	440	75	60	3750 / 540	10500 / 1000		

¹⁾ Reinforced

In individual cases, it may make sense to mount the damper at a different point in the chassis rather than on the hanger bracket.
 Recommendation for dimensioning brackets for installation position I (front-mounted dampers): Rebound 31 kN, Compression 11.5 kN.

4.2.9 Alignment | Conventional axle alignment

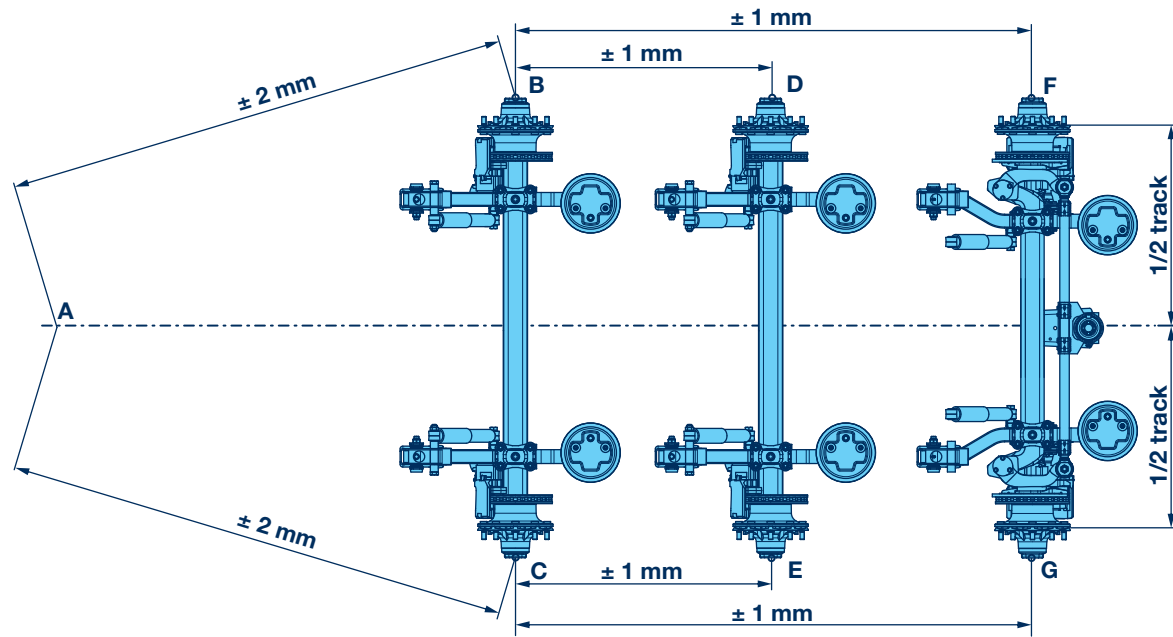

To compensate for manufacturing tolerances, an axle alignment check must be conducted and any corrections made as necessary.

Determine the diagonal dimensions **A - B** and **A - C** for the front axle (reference axle) by means of comparative measurements ($\pm 2 \text{ mm}$ tolerance). Check and if necessary correct the wheelbase dimensions **B - D** and **C - E** for the Center axle, and **B - F** and **C - G** for the rear axle (max. tolerance 1 mm). Measurement is generally carried out by the hub cap centre point (illustration on the right). It can also be carried out using suitable distancing devices or screwed-on calibration tubes.

Care must be taken to ensure that the axle is aligned horizontally (at ride height) in order to obtain a correct measurement.

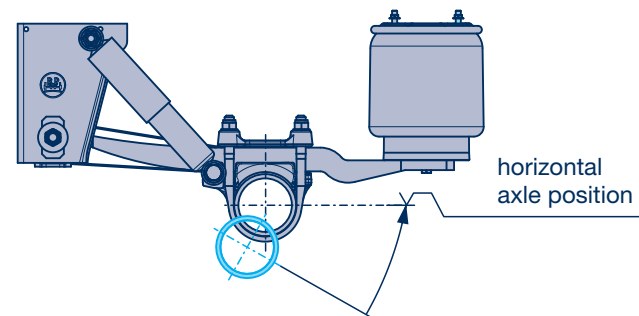

The triangle in the BPW logo is in the centre and can be used for holding a measuring tool:

The maximum possible wheelbase correction per axle is $\pm 10 \text{ mm}$ (see page no. 221) for tracking plates and $\pm 5 \text{ mm}$ (see page no. 220) for adjustable hanger brackets.

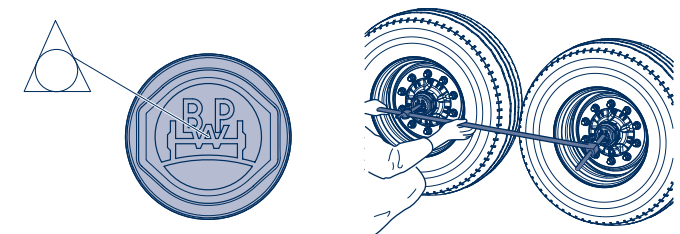

This method only takes into consideration the axle distances but not the individual track values on the axle sides. This is sufficient for axles with optimal track values. This conventional method has a higher probability of incorrect measurements than the laser method (see page no. 219). The measurement of smaller differences across greater lengths can be impacted by factors such as the elasticity in the measuring tool (manual force).

4.2.9 Alignment | Axle alignment with laser measuring system

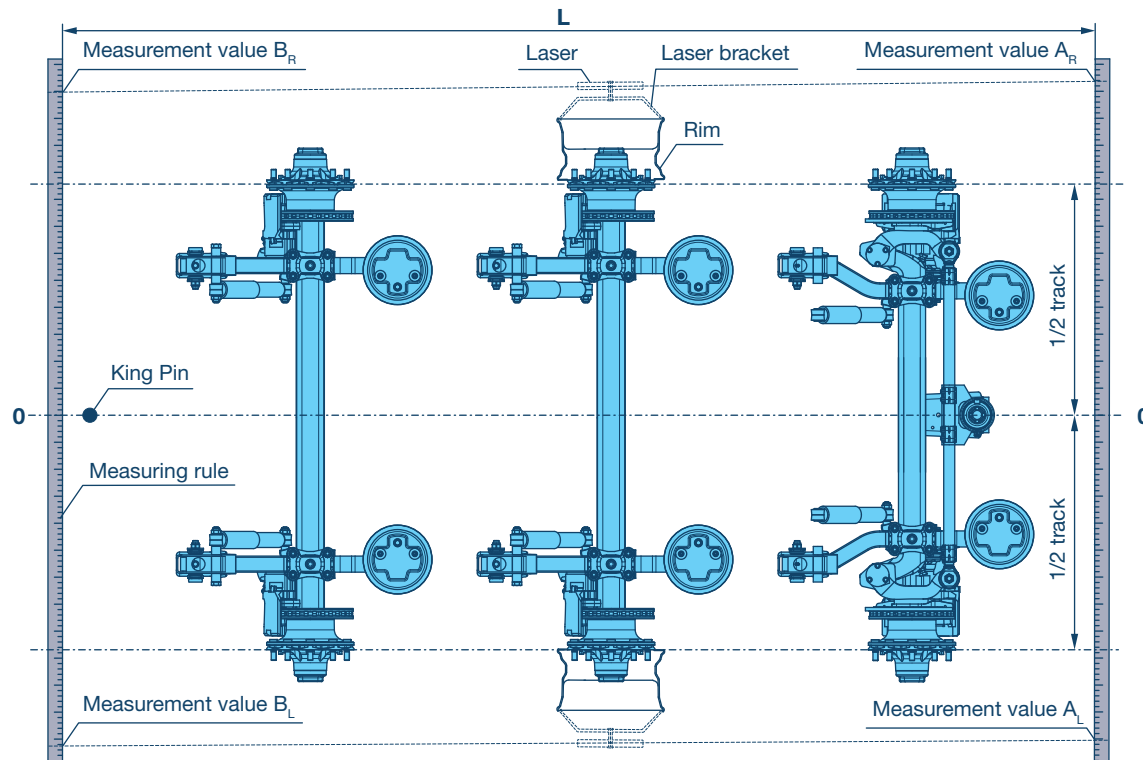

To compensate for manufacturing tolerances, an axle alignment check must be conducted and any corrections made as necessary.

Care must be taken to ensure that the axle is aligned **horizontally** (at ride height) in order to obtain a correct measurement. It is assumed to refer to an unladen vehicle.

The operating and setting instructions of the laser measuring system manufacturer must be adhered to!

The maximum possible wheelbase correction per axle is ± 10 mm (see page no. 221) for tracking plates and ± 5 mm (see page no. 220) for adjustable hanger brackets.

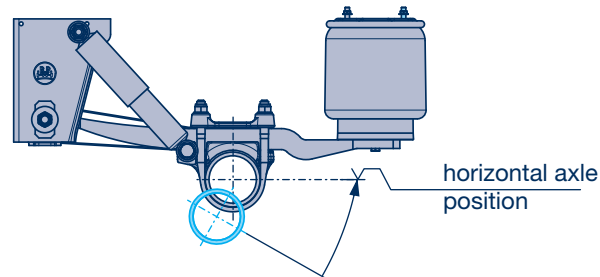

During the tracking process, the tracking values of the right and left wheel side must be averaged for each axle.

Instead of measuring all three axles using the laser method, it is also possible to only track the mid-axle using the laser method. The front and rear axle are positioned relatively to the mid-axle using suitable axle centre distance devices (like during conventional tracking).

$$\frac{(A_R - B_R) + (A_L - B_L)}{L} = \text{Axle track (mm/m)}$$

Positive value = toe-in

Negative value = toe-out

Setpoint specification

for the total track of the axle with the vehicle unladen:

- Rigid axle
 - 1...+5 mm/m for square axles 120 mm, 150 mm
 - 2...+5 mm/m for round axles 146 mm
- Selfsteering axle
 - 0...+4 mm/m (track rod bottom / drum brake)
 - 5...-1 mm/m (track rod top / disc brake)

4.2.9 Alignment | Axle alignment correction with adjustable hanger bracket

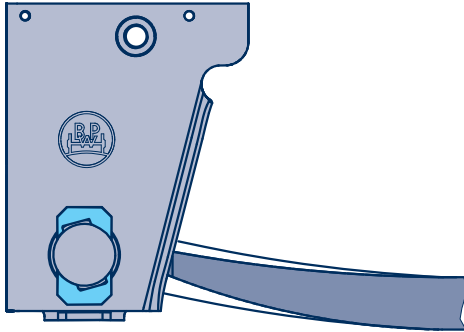

General

It is necessary to check the tracking accuracy during installation as well as after repairs on axles, hanger brackets or trailing arms. The measurement of diagonal dimensions and wheelbases is carried out as described on pages 218 / 219.

If an alignment is necessary, it can be carried out as follows:

Note:

The spring U-bolts must not be loosened on adjustable air suspension hanger brackets.

Axle alignment correction:

1. Raise and support the vehicle frame at ride height.
2. Deflate air bags.
3. Slacken the lock nuts on the spring bolt.
4. Align the front axle (reference axle). To do so, slide the adjusting plates upwards or downwards with light hammer blows (see fig.).
5. Make sure that the inner and outer adjusting plates on each hanger bracket are adjusted symmetrically!
6. Tighten lock nut on the spring bolt to the specified tightening torque.
7. Check the correct alignment of the center and rear axle and re-align if necessary.
8. Inflate the air bags and remove supports from underneath the vehicle.

For off-road use the adjusting plates can be tack-welded after track adjustment.

Tightening torques *see chapter 4.2.13.*

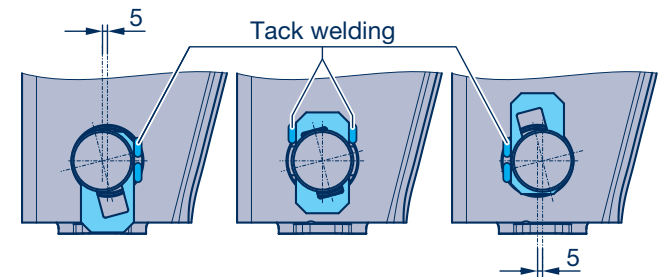
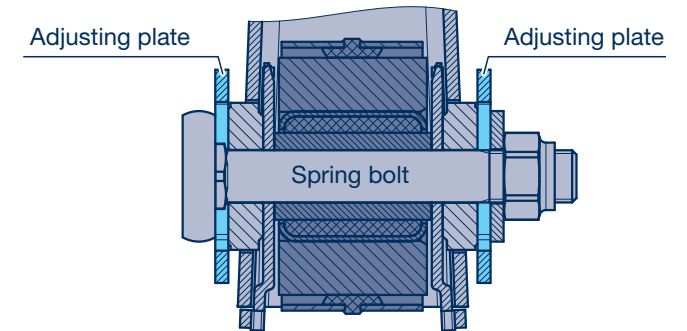

4.2.9 Alignment | Axle alignment with rigid SL hanger brackets with tracking plates

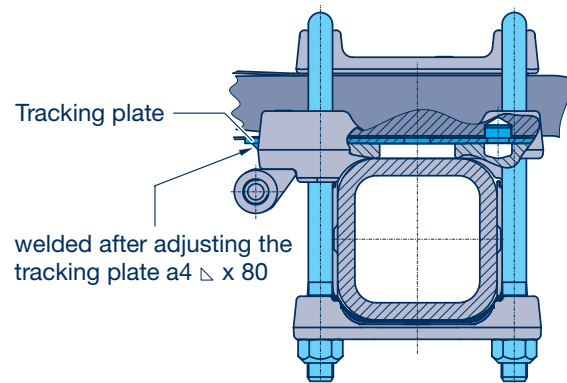

General

It is necessary to check the tracking accuracy during installation as well as after repairs on axles, hanger brackets or trailing arms. The measurement of diagonal dimensions and wheelbases is carried out as described on pages [218 / 219](#).

If a track correction is necessary, it can be carried out as follows:

Axle alignment correction:

1. Raise and support the vehicle frame at ride height.
2. Deflate air bags.
3. Loosen the spring U-bolts.
4. If necessary, grind off the welding seam on the tracking plate and spring pad / spring plate.
5. Align the front axle (reference axle).
6. Tighten the spring U-bolts evenly.
7. Check the correct alignment of the center and rear axle and re-align if necessary.

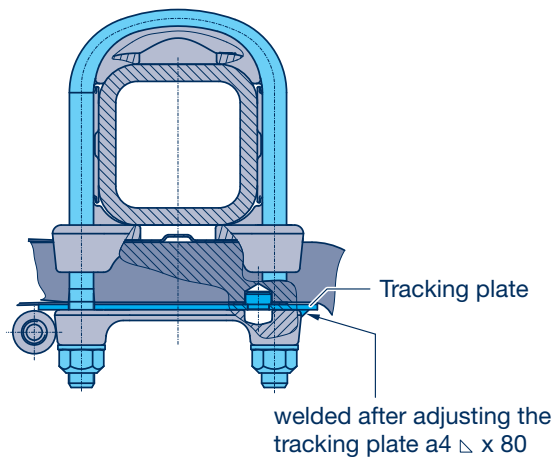

8. Tighten the spring U-bolts evenly and weld all tracking plates to the front edge of the spring pads / spring plates.
9. Inflate the air bags and remove supports from underneath the vehicle.

Tightening torques [see chapter 4.2.13](#).



For all welding operations, the trailing arms, spring U-bolts, air bags, plastic pipings and shock absorbers must be protected against flying sparks and weld spatter.

The earth terminal should under no circumstances be attached to the trailing arm, spring U-bolt or hub.

It is not permitted to weld the trailing arms!

4.2.9 Alignment | Track adjustment for self-steering axles

Self-steering axles have different setpoint specifications for drum or disc brake design.

Reason: Different steering rod positions influence the track when the axle is loaded. The axle beam bends under the load and triggers a slight steering movement.

- With drum brakes (steering rod under axle beam), this tends to go slightly in the direction of toe-out
- With disc brake (steering rod above axle beam) this goes in the direction of toe-in

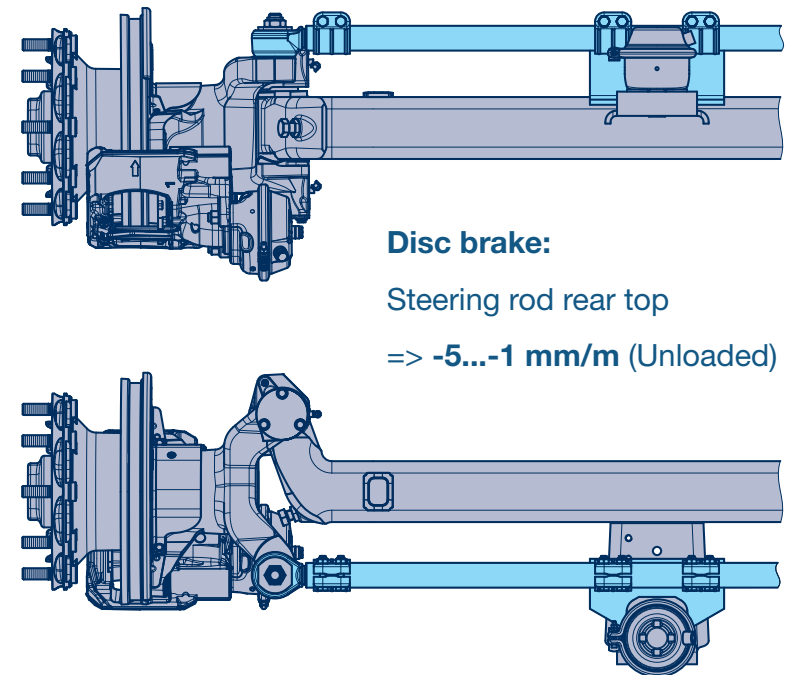
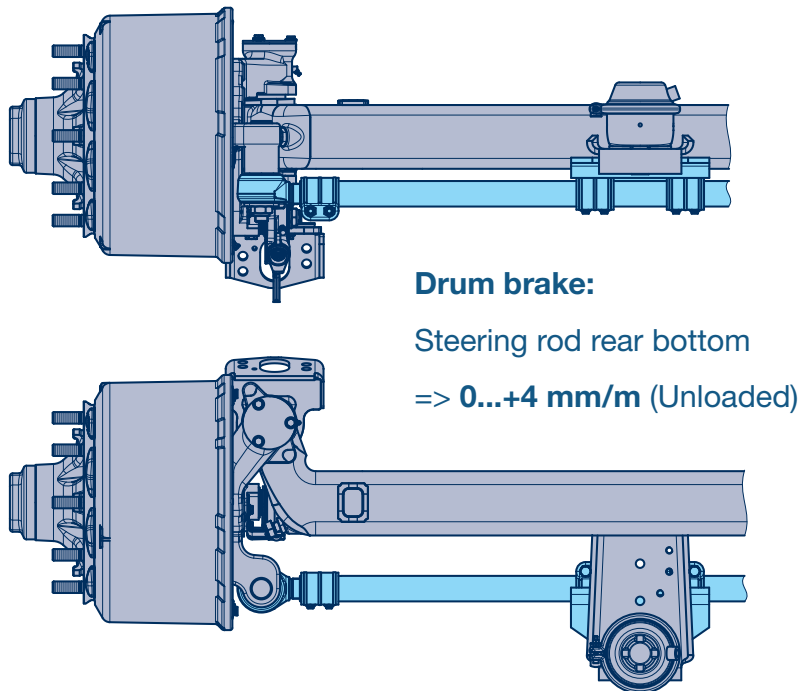

4.2.10 Air suspension installation | General

The BPW air suspension kit is only as good as its installation. If installed incorrectly, the BPW warranty becomes null and void.

The air suspension is supplied with compressed air from the brake system via a pressure limit valve.

The air tank pressure is approx. 6.5 bar. An air supply of 20 litres is recommended for each axle, lifting and lowering demands correspondingly more.

Without an appropriate air supply there is a risk for safety as no air will remain for the air suspension if the wheel brake has a high air consumption.

On request, BPW also supplies installation parts and plans for common air suspension installations. The installation plans identify the valves using the ISO illustration method.



To achieve good axle load equalization, the piping connecting the air bags should not have an inner diameter of less than \varnothing 8 mm (e.g. \varnothing 10 x 1).

Example for air suspension installation: Tri-axle suspension, without lifting and lowering, with two-sided axle lift

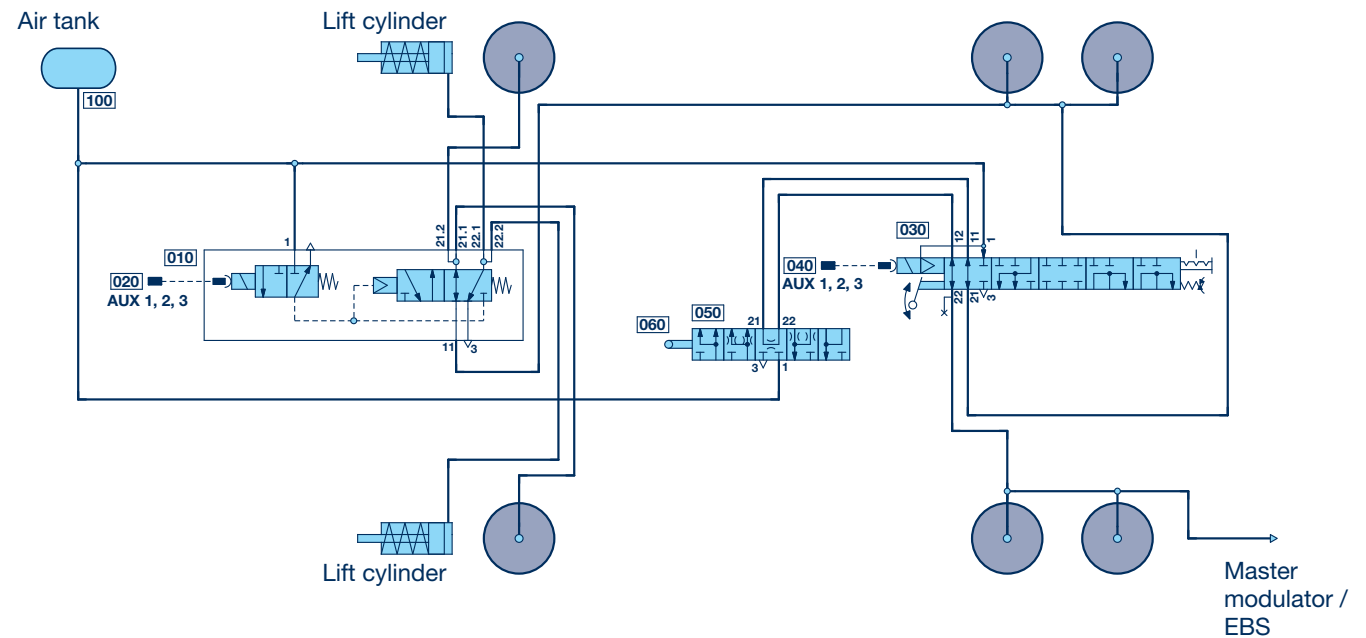

- 010 Lift axle valve
- 020 Connection cable EBS
- 030 Raise and lower valve
- 040 Connection cable EBS
- 050 Air suspension valve
- 060 Connection to the axle beam (see page no. 225)
- 100 Air tank

4.2.10 Air suspension installation | Single and dual-circuit air suspension installation

BPW air suspension kits feature a high roll stability for low side tilt when cornering, leading to excellent road safety. This high roll stability is achieved by supporting the superstructure especially with the axle beam trailing arm unit when cornering.

The support from the air bags also has an impact, albeit a much smaller one.

For dual-circuit air installation kits, the air bags on the right and left sides of the vehicle are pneumatically separated and are only connected together by a transverse throttle in the air suspension valve. This ensures that the air pressure can compensate slowly when cornering. This creates an additional stabilizing effect when cornering quickly in different directions.

Single-circuit air installation kits (e.g. through a distributor block) do not have this stabilising effect.

Due to the long-standing experience of using single-circuit air installations gathered as well by now, these single-circuit systems can also be approved without reservations for standard applications.

4.2.10 Air suspension installation | Air suspension valve / height sensor

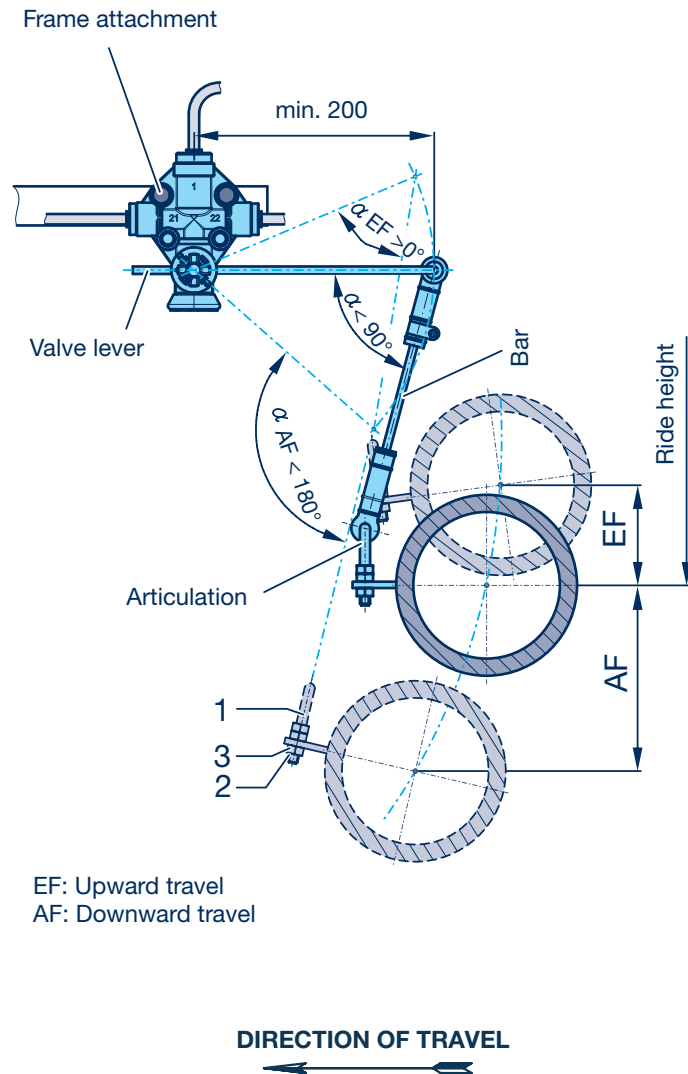

General

BPW air suspension axles are prepared as standard with a support for an air suspension valve.

This regulates the air bag pressure according to the respective vehicle load, thereby holding the vehicle at a constant ride height. The air suspension valve is screwed to the vehicle frame and connected to the axle via the lever and bar. The pivot link is located in the middle of the axle, on tri-axle suspensions at the centre axle, on two-axle suspensions on the rear axle. In special cases (e.g. axle lift device, large vehicle slope) the air suspension valve may also be connected to the front or rear axle.

The valve lever, which is at least 200 mm long, is positioned horizontally in the direction of travel. For testing purposes, the lever is pressed slightly downwards. The air must be released into the atmosphere via the pressure relieve valve.

If the air is directed into the air bag, the valve shaft must be rotated by 180°.

The valve lever must be switched over for this purpose. The ride height is set by adjusting the link rod in the rubber joints and then fixing this position with the lock nuts.

The vehicle must be standing on a level ground when this setting is made. The setting can be performed when the vehicle is laden or unladen. Electronic ride height measuring devices can also be installed.

Stroke limitation of air suspension axles for vehicles with a raising and lowering feature to adjust to the height of ramps can also be achieved with an air suspension valve with integrated lock, [see page no. 227](#).

4.2.10 Air suspension installation | Air suspension valve / height sensor

Body inclination

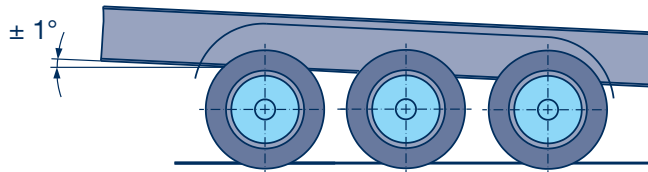

The max. body inclination of the semi-trailer must not exceed $\pm 1^\circ$.

Ride height

The ride height of the air suspension axles should be set to the permitted range indicated according to the corresponding documents (data sheets).

With single axles a minimum upward travel of 60 mm is necessary. With multi-axle units a minimum upward travel of 70 mm is necessary.



The air suspension can be checked by activating the compression stroke to the air bag bump stop, and then the extension stroke to its limits (shock absorber, air bag length).

The angles stated must be maintained to avoid the valve linkage going over centre.

Due to the strong stabilizing effect, the use of two air suspension valves for regulating the sides is not recommended.

4.2.10 Air suspension installation | Air suspension valve / height sensor

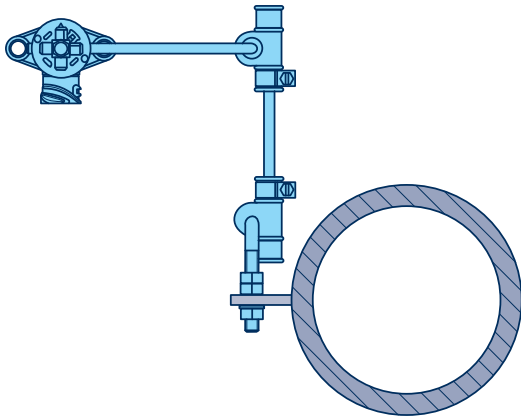

In addition to conventional air suspension valves operated by lever mechanisms, electronic air suspension modules are often found in vehicles on the market. The conventional air suspension valve is replaced with a robust ride height sensor and a multifunctional air suspension block is added.

The sensor is usually connected to the brake system, which also controls the valve functions.

The ride height is regulated in a closed regulation circuit, which has advantages compared with a conventional air suspension system when regulating ride heights in terms of parameters and diagnostics options for the vehicle manufacturer and driver.

The mechatronic ride height adjuster also provides further advantages compared with conventional valve technology:

- Low air consumption as the level regulation is not linked to the dynamic upward / downward movements
- Easy option for realising several ride heights
- Integrated shutoff
- Reset-to-ride function without additional valve technology
- Rapid lifting and lowering due to large valve cross-sections
- Lift axle control with residual pressure tank, often integrated in the valve block for traction assist and maneuvering aids
- Operability of the trailer suspension from the truck or via mobile devices
- Installation advantages due to reduced wiring and piping

4.2.10 Air suspension installation | Raising and lowering

Today, lift and sink valves, often also called rotary disc valves, provide further functionalities and switchings for influencing the ride height in addition to the original function of raising or lowering the ride height of a vehicle. Depending on the air suspension valve installed, lift and sink valves can be designed as single or dual circuits. The lift and sink valve is switched behind the air suspension valve and connects the air bags of the axle with the air suspension valve.

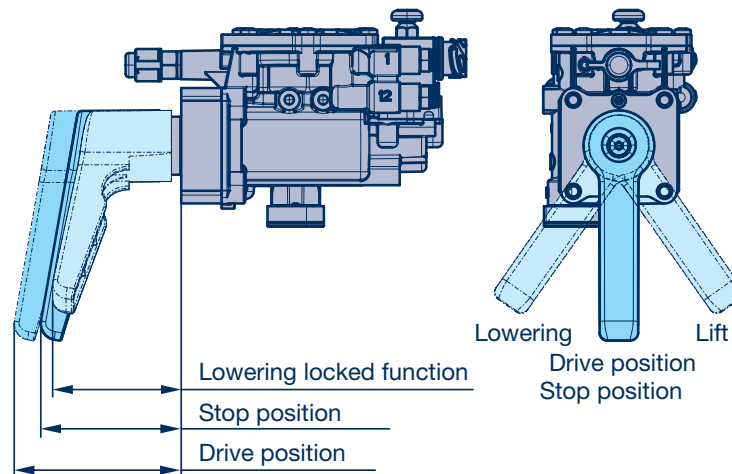
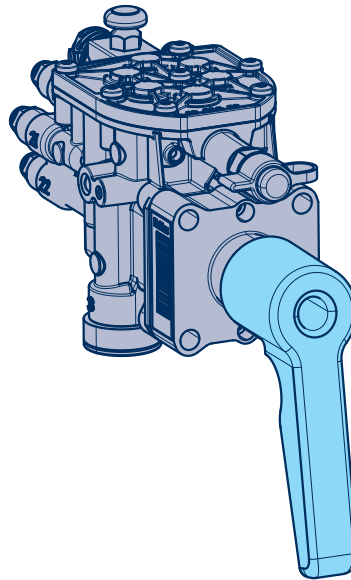

Ride height function

The ride height is usually secured through the air suspension valve, which inflates and deflates the supporting air bags, depending on the ride height, thus keeping it constant. The connection of the supporting air bags of the axles with the air suspension valve is also maintained.

Stop function

In this switching position, the link between the air suspension valve and supporting air bags is interrupted and the last ride height set with the lift and sink valve remains intact. Changes to the ride height caused by loading or unloading are not compensated.

Raising function

To raise the ride height, the connection of the air bags with the air suspension valve is interrupted with the lift and sink valve and the air bags are inflated with supply pressure for raising the vehicle.

Lowering function

To lower the ride height, the connection of the air bags with the air suspension valve is interrupted with the lift and sink valve and the air bags are deflated for lowering.

4.2.10 Air suspension installation | Raising and lowering

Dead man's switch

The so-called dead man's switch ensures that the vehicle is only raised or lowered if the operator holds the operating lever in the corresponding raising or lowering position. Once the lever is released, it automatically returns to the stop position. This prevents the uncontrolled raising and lowering of the vehicle superstructure.

Lowering locked function

To load or fix vehicles in combination traffic, it may be necessary to lower the vehicle right down to the air bag stop and to maintain this condition for the duration of the vehicle transport. This function is often also called ro-ro function (roll on / roll off).

Resetting the vehicle to ride height

The vehicle is primarily reset to ride height, often also called reset-to-ride function, through a switching impulse of the brake system. The ABS/EBS switching impulse is triggered once a certain speed is exceeded (e.g. 15 km/h) and operates a magnetic valve integrated in the lift and sink valve. This magnetic valve returns the operating lever to the driving position and therefore ensures that the air bags are reconnected to the air suspension valve for the journey.

Stroke limitation during compression

The upward travel is limited by a rubber bump stop inside the air bag. The downward travel must be restricted under certain operating conditions.

Versions of stroke limitation during rebound

The stroke limitation can be carried out via an air suspension valve with integrated shut-off (see page no. 227) or a separate shut-off valve. The shut-off valve is bolted to the vehicle frame and connected to the axle with a return spring attached to the tension pin. After the maximum lift height is reached, the air supply to the air bag is shut off and the stroke thus limited.

Alternatively, the stroke limitation may be in the form of a catch-strap. When assembling the catch straps, their exact length must be ensured as well as that they rub as little as possible on the axle beam, do not collide with other components (e.g. disc brake cylinders, brake camshaft or pipes) and have sufficient ground clearance.

The limitation of raising and lowering devices without stroke limitation in the form of shut-off valves depends on the shock absorbers or air bag, depending on design. The shock absorbers are equipped with a travel limiter; however they are not designed to operate with airbag pressures up to approx. 8.5 bar.

Air bag type 30, 30 K, 36 or 36 K

As a rule, no stroke limitation is required for type 30, 30K, 36 or 36K air bags when a rotary disc valve with dead man's lever is installed.

Long-stroke air bags

Stroke limitation is required in vehicles with a raising and lowering device and type 36-1 / 36-2 / 36-5 air bags.

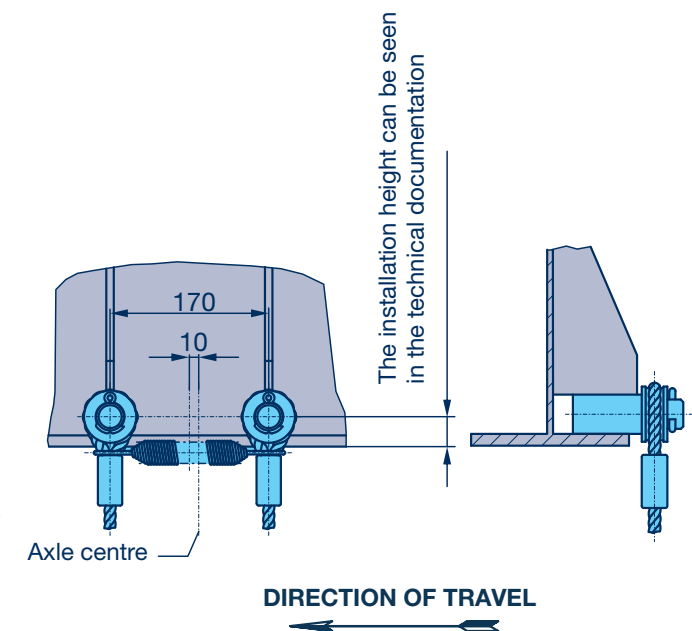

4.2.10 Air suspension installation | Raising and lowering

Rapid unloading

With vehicles where the payload is unloaded quickly, e.g. tippers, container vehicles, coil vehicles etc., stroke limitation is required by means of rapid venting of the air bags.

Crane, railway or ship loading

With vehicles for crane, railway or ship loading, BPW recommends split air bag pistons, Kombi Airbag system. If not expressly demanded in the technical documentation (*see page no. 199*), no stroke limitation is needed when the Kombi Airbag is used. In this case, the shock absorber is the lower stop. Vehicles, especially those with split air bags (Kombi Airbag) must not be moved in an unpressurized state when manoeuvring in ferry traffic.

Traction assist

Even if the vehicle is fully loaded, the semi-trailer front axle can be raised to increase the traction of the driven axle in the truck, e.g. in wintry conditions. In accordance with 97/27/EC, Section 3.5 of Annex IV, the deflation of the front axle of the suspension unit of the tri-axle semi-trailer correspondingly increases the load of the axles remaining on the ground. The load on these two axles may then be increased by 30 %, corresponding to the following value:

18,000 kg plus 30 % = 23,400 kg (11,700 kg per axle).

The air bag pressure of the axles on the ground also increases significantly, e.g. when using the

30 air bag (L1 = 500 mm and L2 = 380 mm), from 4.7 bar to 6.65 bar. It must be ensured that the reserve pressure in the tank is approx. 1.5 bar higher. This can prevent the temporary drop down to the bumper of the air bag and therefore an additional, impermissible load increase.

The above axle load increase is only acceptable under the conditions stated in the above mentioned 97/27/EG. After the vehicle is rolling, the load must automatically rest back on the axle before exceeding 30 km/h.

4.2.11 Axle lifts | General

BPW air suspension axles can be equipped with axle lift devices. With tandem suspensions, one axle can be raised,

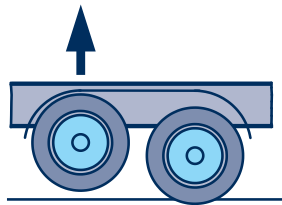

or max. two axles with tri-axle suspensions.

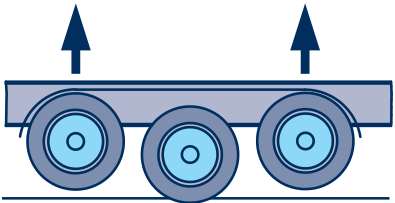
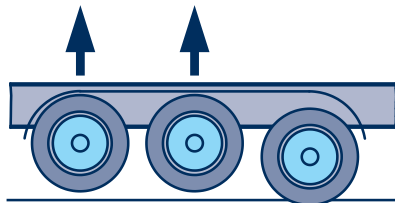

With steering axle

In vehicles with BPW self-steering axles, series LL, a "rigid axle/steering axle ratio" of 1:1 is permitted. With tri-axle suspensions a rigid axle may also be raised.

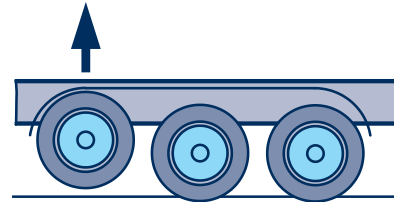

It is recommended to raise the front axle of a suspension due to the improved ground clearance (gradient of superstructure) and the longer wheel base, thus resulting in more stable driving characteristics.

In the case of vehicles with axle lift devices, ground clearance for the raised axle must be ensured.

The statutory provisions regarding turning circle requirement must be observed!

Lift axles reduce rolling resistance and tire wear. In the VECTO calculation (for O3 and O4 trailers or semitrailers with closed, box-shaped bodies), vehicles with lift axles therefore receive a bonus. For example, 0.4 % fuel consumption is accounted for in the case of three-axle trailers in long haul transport, 3 % in regional transport, and 4.4 % in urban transport. The additional use of steering axles significantly increases the bonus.



BPW air suspension kits and axle lift devices only operate as well as the installation of the air suspension: The reliable functioning of the axle lift and the correct rolling of the air bags should be ensured by means of the air installation and its activation times.

If installed incorrectly, the BPW warranty becomes null and void.



4.2.11 Axle lifts | Overview of designs

Two-side axle lift

Can be used on all axles except long-stroke air bags, the installation space in front of the air suspension hanger brackets and in the vehicle centre remains free.

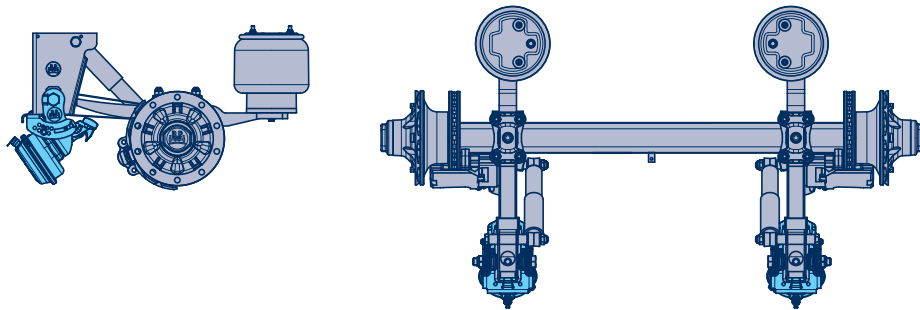

Side axle lift

For raising the front axle

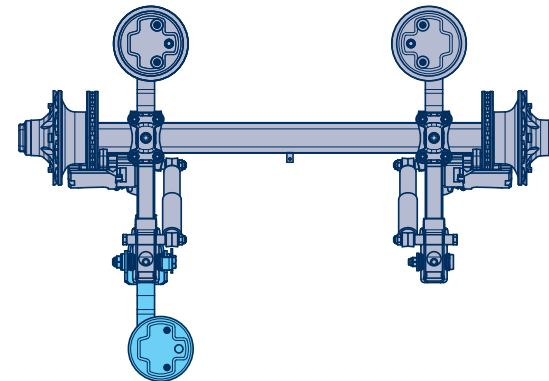

Central axle lift

For raising the front, central or rear axle

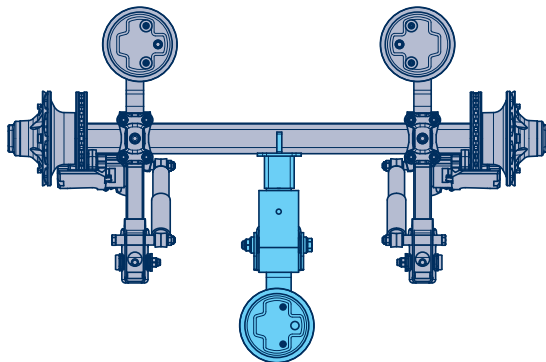

Central axle lift (up to 9 t)

For raising the front, central or rear axle

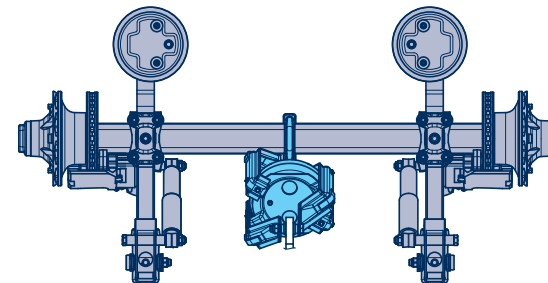

4.2.11 Axle lifts | Lift stroke

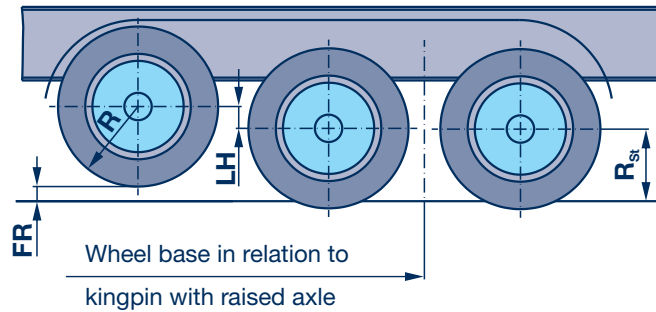

The ride height of air suspension units equipped with an axle lift device should be set at a minimum of approx. 100 mm upward travel to create sufficient ground clearance beneath the raised axle.

If it is impossible to adjust the ride height to the minimum upward travel, corresponding air suspension valve technology must be used to create sufficient ground clearance with a second ride height.

The axle lift stroke equals the suspension upward travel stroke. The clearance under the tyre is reduced by the compression of the tyres.

FR = Clearance

LH = Lift stroke

R_{St} = Half tyre diameter laden

R = Half tyre diameter unladen

Clearance under the tyre

$$FR = LH - (R - R_{St})$$

$$LH \text{ min.} = 100 \text{ mm}$$

4.2.11 Axle lift | Double-sided axle lift

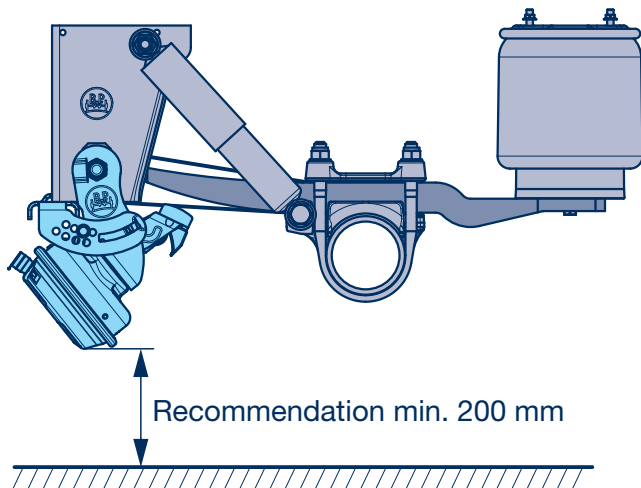

For rigid and adjustable hanger brackets, channel crossmembers and aluminium hanger brackets (not in conjunction with long-stroke air bags).

Function

In the two-side axle lift, the lifting force is generated by one integrated diaphragm cylinder on each side. The pivot point is the spring bolt, meaning that no other installation preparations have to be planned by the vehicle manufacturer other than the air installation.

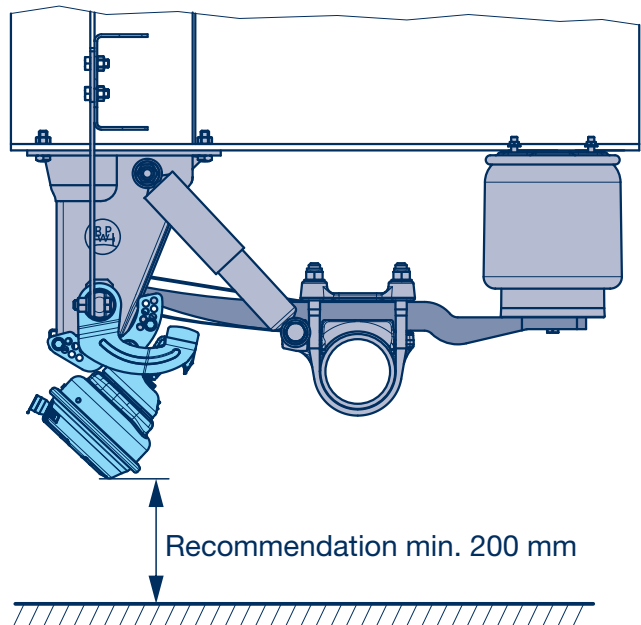

For bolt-on AL II hanger brackets

Significantly easier assembly thanks to attachment to the hanger bracket with 2 screws.

The spring bolt does not have to be removed.

Advantages:

- Can be used for disc and drum brake axles
- Installation space in front of the hanger bracket (e.g. for pallet boxes) and in the centre of the vehicle remains free
- Easy subsequent assembly, if required
- Compact design, good ground clearance
- Low weight
- Installation position can be set for different suspension types
- Robust design
- Durable technology thanks to the use of tried and tested brake components



The correct double-sided axle lift and pinning position are shown in the BPW technical documents.

The installation position can be seen in the included installation drawing.

The pinning position must be correct for the design and ride height to ensure reliable functions.

4.2.11 Axle lift | Side axle lift

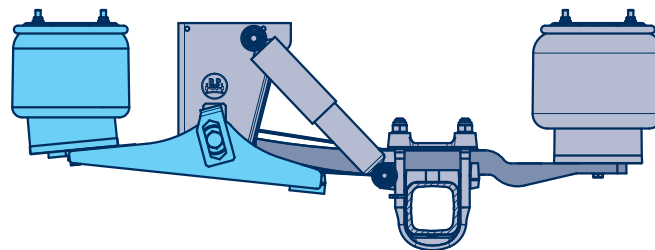
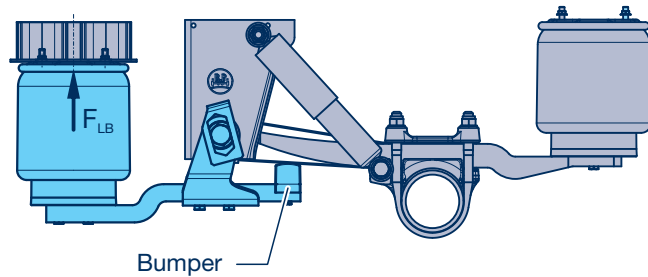

Side location is suitable for lifting the front axle of the suspension unit. The lifting arm is assembled on the front hanger bracket using the spring bolt bearing.

The air bag sits centrally on the lever arm ($V = 0$ mm) and is attached under the vehicle long-beam. Additional crossmembers are not required.

The top plate of the lifting bag can be offset to the side by ± 20 mm.

BPW provides a sidewise mounted axle lift for improved grounds clearance, especially for air suspension units for low-loaders.

The air pressure for the air bag of both versions must be limited by a reducing valve, depending on the design.

Force on lifting bag BPW 30 ($p = 5.0$ bar):

$$F_{LB} = \frac{5.0 \text{ bar}}{0.00023 \text{ bar/N (spec. air bag pressure)}} = 21,750 \text{ N}$$

Force on lifting bag BPW 36 ($p = 3.5$ bar):

$$F_{LB} = \frac{3.5 \text{ bar}}{0.000156 \text{ bar/N (spec. air bag pressure)}} = 22,450 \text{ N}$$

The dynamic axle movements are not transferred to the axle lift device and therefore no consistent initial pressure is required in the lifting bag, even if the axle lift is not being operated.

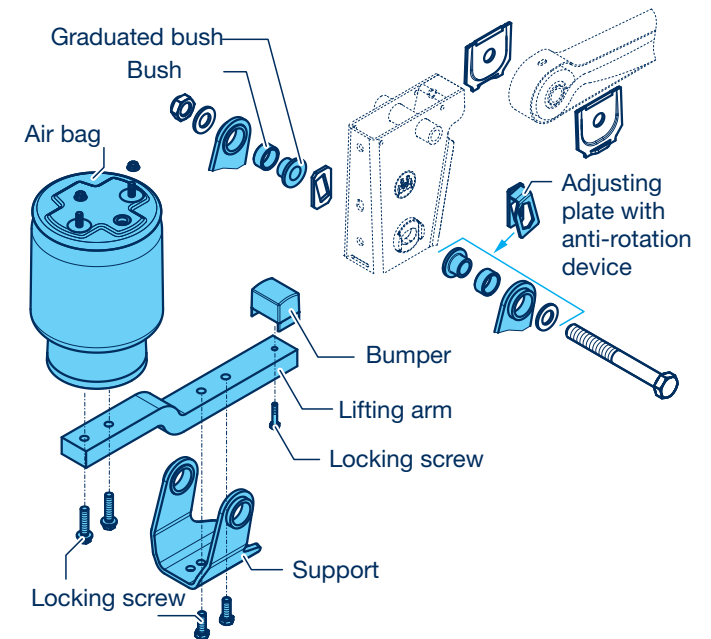

The installation position and mounting of the axle lift device can be seen in the BPW technical documents and the supplied installation drawing.

4.2.11 Axle lifts | Central axle lift

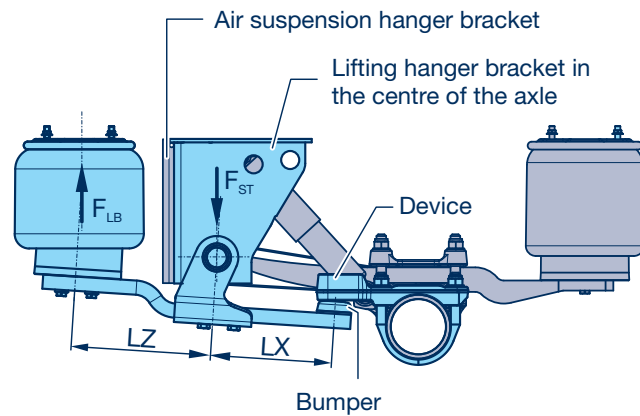

The lifting device can be arranged in the centre of the axle for lifting the central (rear) suspension axle or if space is limited.

This axle lift device is attached to a crossmember on the vehicle frame via an additional lifting hanger bracket in the centre of the vehicle.

The installation position of the lifting hanger bracket can be seen in the technical documentation.

The bumper on the axle comes as a weld-on or bolt-on version.

The lifting bag forces are also to be counteracted by a crossmember.

The air pressure for the lifting bag must be limited by a reducing valve, depending on the design!

Example

- Axle lift device with lifting bag BPW 30
- Pressure reduction valve set at 5 bar.
- Lever lengths $L_x = 280 \text{ mm}$ / $L_z = 320 \text{ mm}$ (from BPW technical documents)

Force on lifting bag BPW 30 ($p = 5.0 \text{ bar}$):

$$F_{LB} = \frac{5.0 \text{ bar}}{0.00023 \text{ bar/N (spec. air bag pressure)}} = 21,750 \text{ N}$$

Force of hanger bracket ($p = 5.0 \text{ bar}$):

$$F_{ST} = \frac{21750 \text{ N} \times 600 \text{ mm}}{280 \text{ mm}} = 46,600 \text{ N}$$

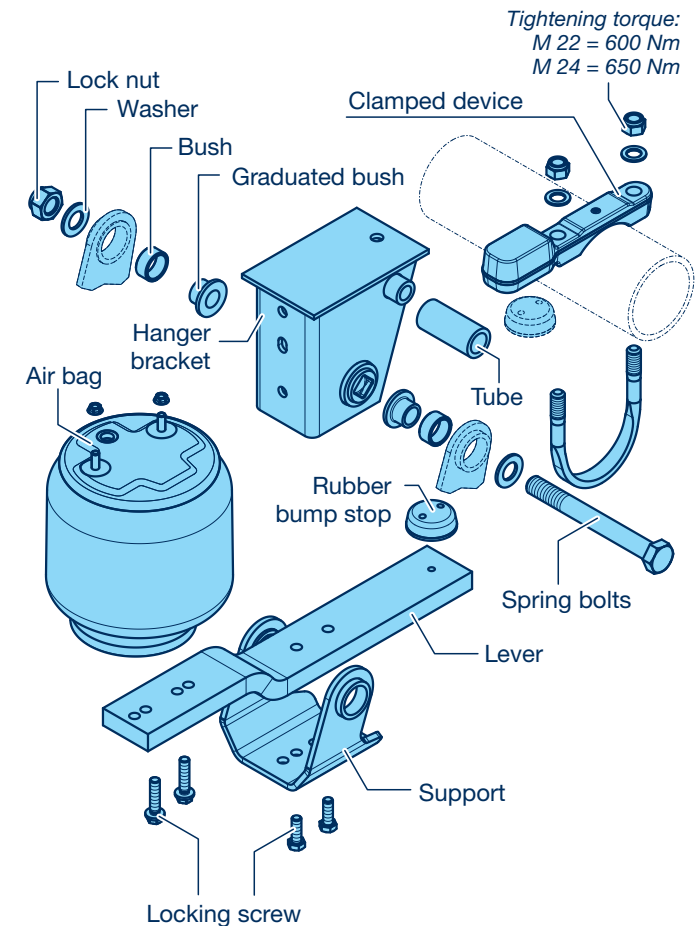

If the crossmember over the lift air bag bracket is not fitted, the torsion moment ($F_{LB} \times L_z$) of the lifting hanger bracket crossmembers must be counteracted.

The crossmember must be dimensioned according to standard safety reserves in the commercial vehicle industry.



The installation position and mounting of the axle lift device can be seen in the BPW technical documents and the supplied installation drawing.

4.2.11 Axle lifts | Central lift (only up to 9 t, ALII)

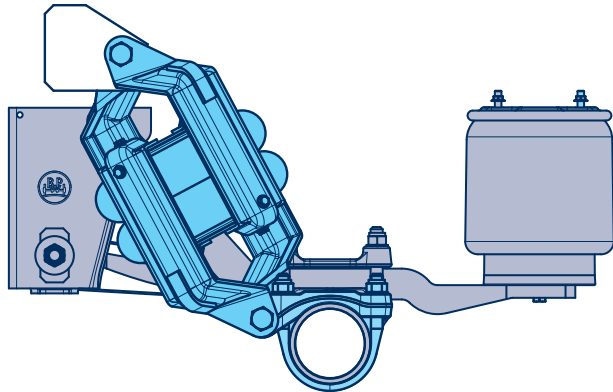

The central axle lift is located in the centre of the axle and used for lifting the centre (rear) suspension axle or if space is limited.

This central axle lift is attached to a crossmember on the vehicle frame in the centre of the vehicle and bolted on to the axle.

The lifting forces must be absorbed with crossmembers that are dimensioned as standard in the commercial vehicle industry.

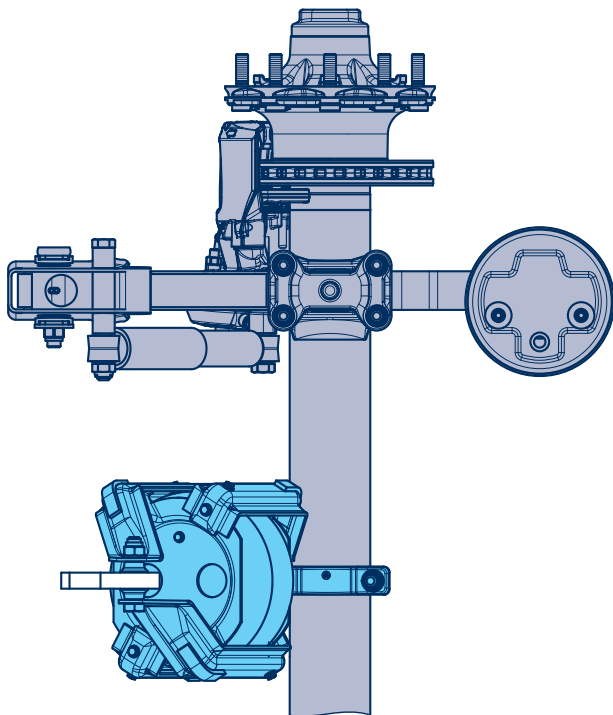

Air installation with pressure retention device

The air pressure in the air bag must be set to max. 6 bar on the pressure control valve.

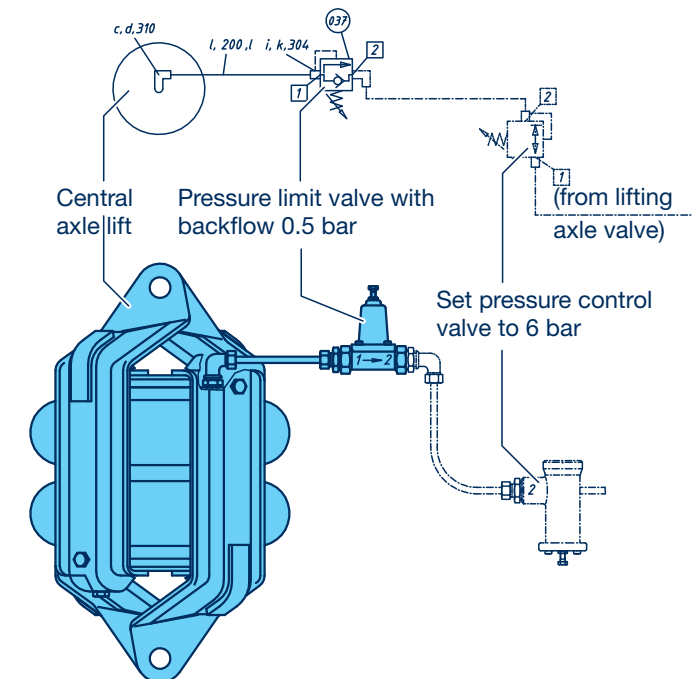

The installation position and mounting of the axle lift device can be seen in the BPW technical documents and the supplied installation drawing.

4.2.12 U-stabilizer

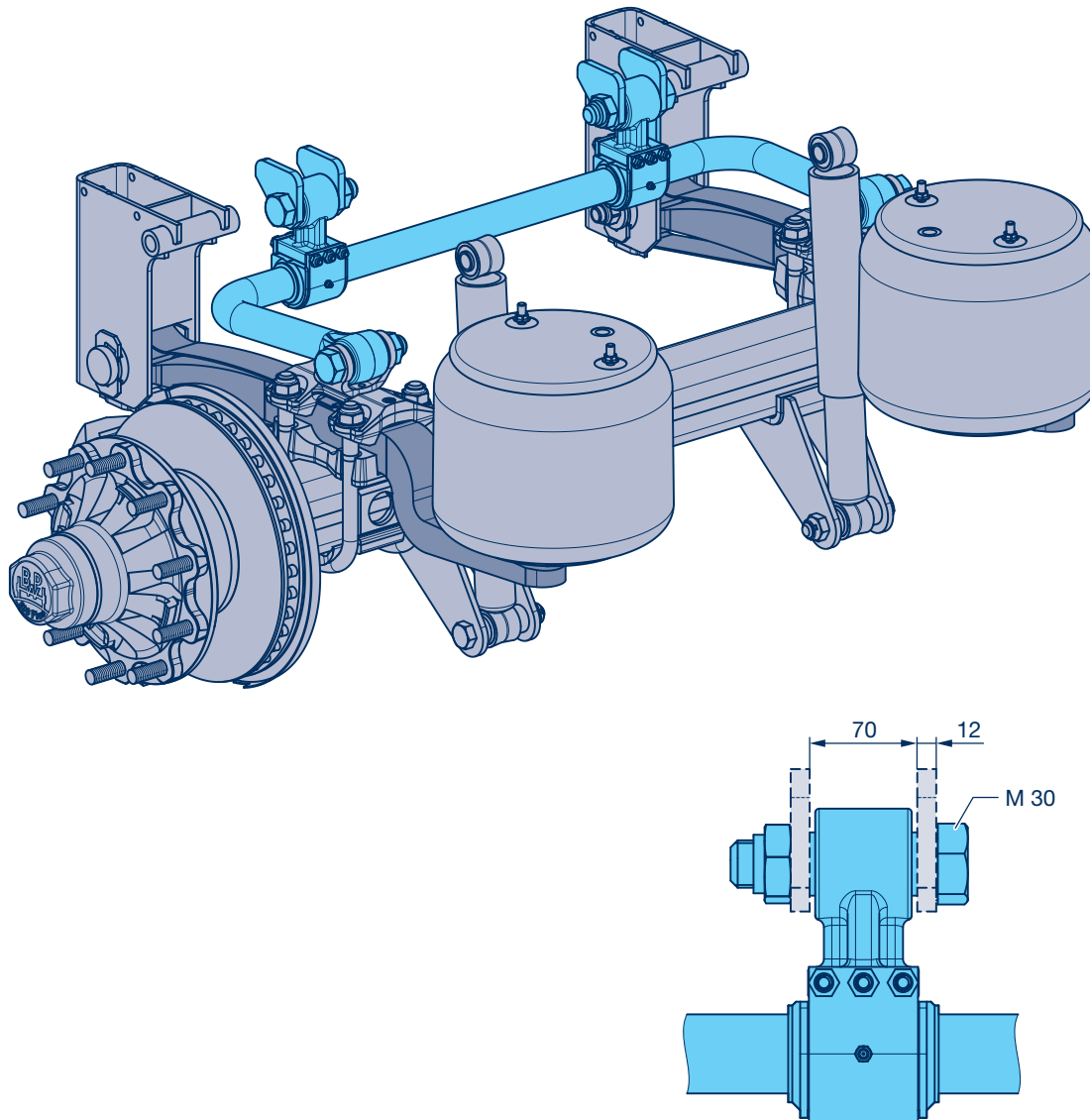

BPW also offers U-stabilizers for air suspension units with increased rolling stability requirements.

The stabilizer is attached to a crossmember in the vehicle frame using two supports and bolted on to the axle in the area of the spring seat arrangement.

The crossmember must be dimensioned according to standard safety reserves in the commercial vehicle industry.

U-stabilizers are available for the standard spring centres, 900, 980, 1100, 1200 and 1300 mm.

The length of the top support is designed by BPW according to the ride height and spring deflection of the air suspension unit.

The bearing points between the U-bolt and top supports must be lubricated by grease nipples in the beginning and also at regular intervals (e.g. with BPW special longlife grease, ECO-Li^{iPlus}).

The U-stabilizer increases the stabilization rate by approx. 6 - 8 % in combination with the strongest trailing arms.



The installation location and assembly of the U-stabilizer should be carried out according to BPW technical documents.

4.2.13 Tightening torques

Lightly grease thread, except spring bolt (item 1)

¹⁾ Apply grease to the threads of the spring U-bolts and nut contact surfaces.

²⁾ BPW does not supply the gusset plate / crossmember bolt connection.

Area	Item	Attachment	Thread	Tightening torque
Spring bolts	1	Spring bolt	M24	650 Nm (605 - 715 Nm)
		Steel hanger bracket / channel crossmember / aluminium hanger bracket	M30	900 Nm (840 - 990 Nm)
U-bolts	2	U-bolts	M20	340 Nm (315 - 375 Nm)
			M24 - 10.9	650 Nm (605 - 715 Nm)
		Spring U-bolt AL II (initial installation) ¹⁾	M22 - 10.9	550 Nm + 90° rotation angle
		Spring U-bolt AL II (test)	M22 - 10.9	550 Nm (510 - 605 Nm)
Shock absorber	3	Upper and lower attachment	M24	420 Nm (390 - 460 Nm)
		Upper attachment, steel hanger bracket / channel crossmember	M20	320 Nm (300 - 350 Nm)
			M24	420 Nm (390 - 460 Nm)
		Upper attachment, stainless steel hanger bracket, welded-on bolt	M24	320 Nm (300 - 350 Nm)
	3A	Upper attachment, aluminium hanger bracket	M24	320 Nm (300 - 350 Nm)
Air bag	4	Attachment top cover plate	M12	66 Nm
	5	Bottom attachment with 2 locking screws	M16	300 Nm
		Bottom attachment with 1 central bolt		300 Nm
	5A	Bottom central nut on Kombi Airbag		130 Nm
	6	Attachment bottom plate on air bag		230 Nm
Axle lifting device	7	Attachment diaphragm cylinder		M16
			M20	350 - 380 Nm
	8	Two-sided axle lift installation	M12	66 Nm
	9	Hexagon screw SW 24	M12	75 Nm
	10	Attachment lifting arm	M16	230 Nm
U-stabilizer	11	Attachment U-stabilizer	M30	750 Nm (700 - 825 Nm)
	12	Lock nuts of securing bolts for shaped plate	M10 - 10.9	53 Nm
Bolted-on hanger bracket	13	Spring bolt / gusset plate	M18 x 1.5	420 Nm (390 - 460 Nm)
	14	Gusset plates / crossmember (use M 16 at a minimum!) ²⁾	M16 - 10.9	Max. permitted Md.
	15	Bottom flange / hanger bracket (knurled screw)	M16	260 Nm (240 - 285 Nm)

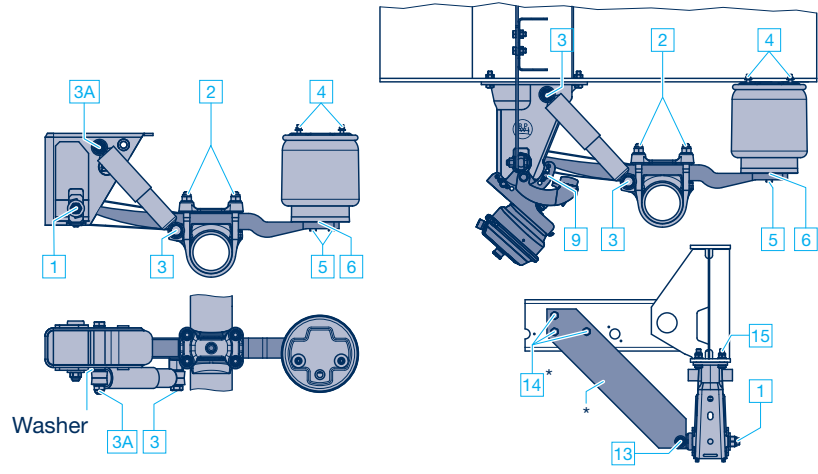
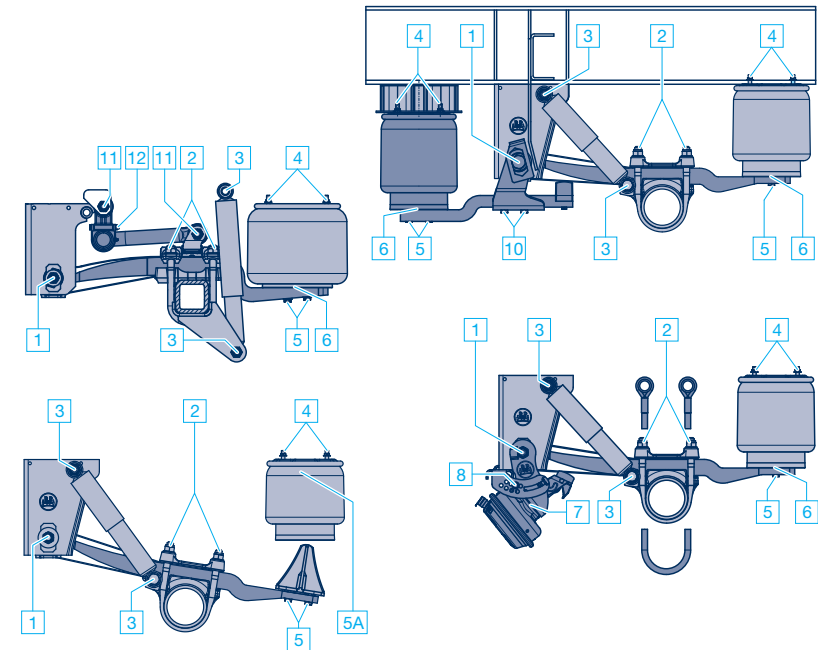

Aluminum hanger bracket

Bolted-on hanger bracket

4.2.14 Surface treatment

BPW running gears come with KTL + Zn anti-corrosion coating (cathodic dip coating with zinc phosphating) which undergoes salt-spray testing in accordance with DIN EN ISO 9227. Practical tests show that this KTL+Zn surface treatment is even more resistant to corrosion than conventional primers and subsequent top-coats. Thus, there is no need for conventional topcoats on KTL+Zn-treated components, unless there are special colour and gloss requirements.

The KTL+Zn coating can generally be top-coated with single-component, air-drying synthetic resin-based vehicle chassis paints as well as two-component, solvent-based or water-based coating systems. However, emulsion paints, architectural paints or nitrocellulose paints must not be used.

When applying the top coat, it must be ensured that the following areas of the running gear have been covered or masked: wheel contact surfaces, booster bracket contact surfaces to the drum brake cylinder and their attachment nuts, brake discs, brake lining shaft, exciter rings, ABS sensors, disc brake cylinder contact surfaces (unless already installed), all air suspension hanger bracket contact surfaces (internal and external) and the bolt-on parts of the spring bolt bearing, bolt-on parts of the shock absorbers and the air

bag contact surface on the trailing arm.

The reason is that contact surfaces between dynamically loaded and bolted components are subject to micro-movements which result in the destruction of the coating and gaps forming at a later date. The clamping assembly could detach as a result.

The total thickness of the coating must not exceed 30 µm on the contact surfaces of the bolt-on parts. For hot-dipped hanger brackets, the maximum coat thickness around the bolt-on parts is 100 µm.

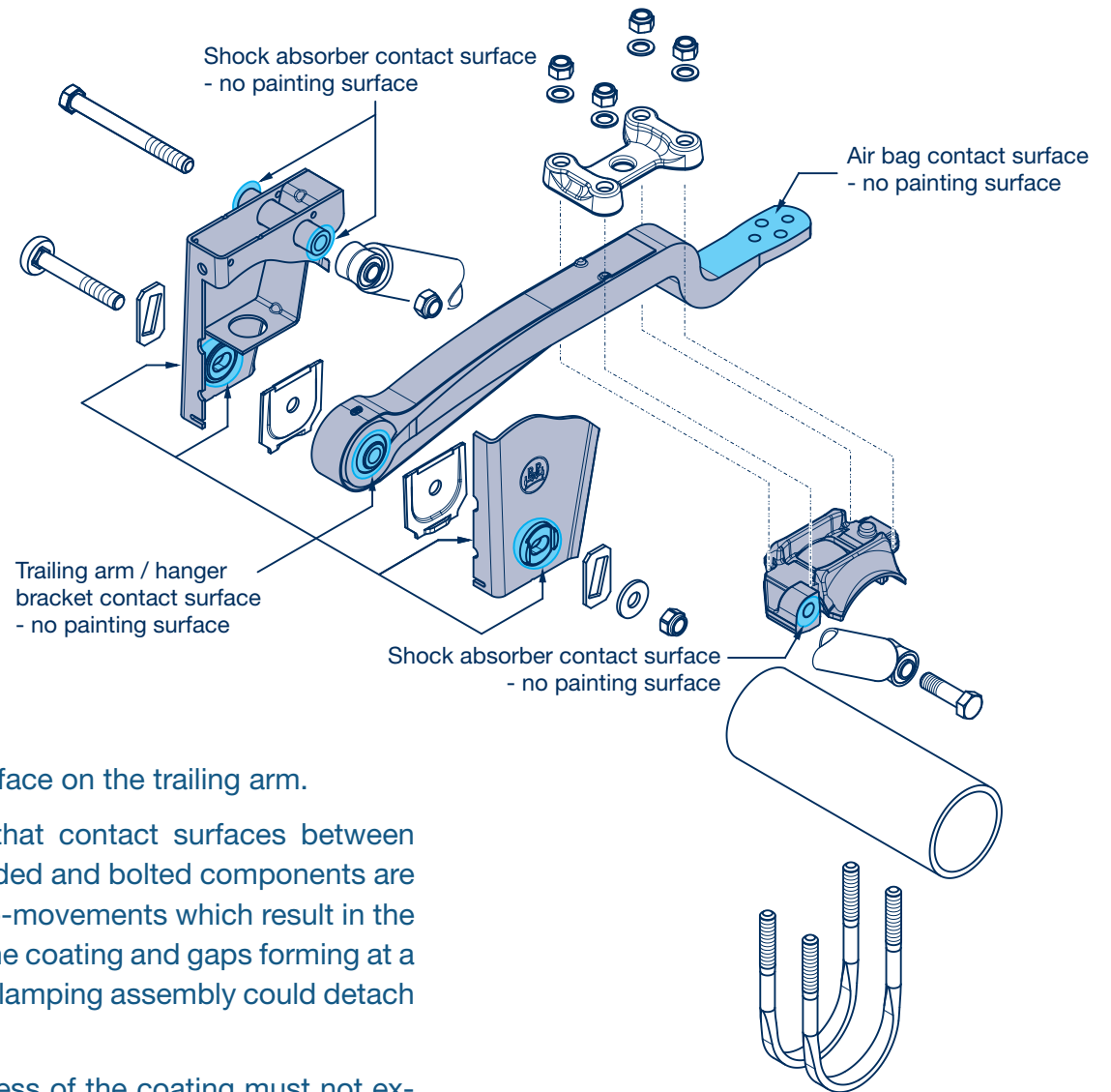

4.2.15 Characteristic curves and data sheets on My BPW | TE-1242.0 Characteristic curves for air bag

The characteristics curves serve to estimate the load index of the air bags which declines over the stroke, e.g. for the raising and lowering function. A diagram sheet is available for each air bag type and each transmission ratio between the trailing arm and air bag mount (L1, L2). The iso bars (from 1 bar to 8 bar air bag pressure, from TE-1188.0) describe the relation between the lifting capacity (of the suspended dimensions per axle) and stroke in the sense of the axle spring deflection between minimum ride height (empty, without air) and maximum ride height (fully extended air bag). The following applies approximately for the suspended dimensions and axle load (axle load on the ground less the weight force of axle, wheels and part of the suspension):

$$FA_{gef} = FA \times 0.92$$

[Characteristics curves for air bags](#)

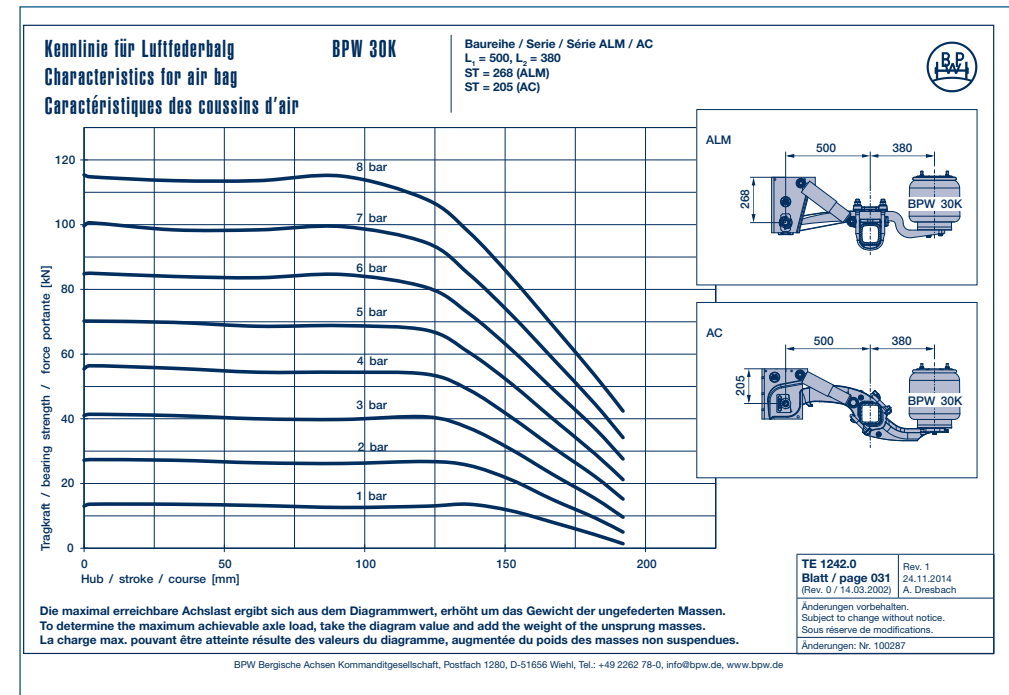

4.2.15 Characteristic curves and data sheets on My BPW | TE-1188.0 Bellows pressure diagrams

The characteristics curves serve to determine the air bag pressures based on the load status of the axles. There is a diagram sheet for each air bag type and each transmission ratio between the trailing arm and air bag mount (L1, L2). The straight lines are allocated to the maximum axle loads and describe the relation between the air pressure in the air bags and weight ratio (part load / full load of the axle loads on the ground GA).

[Air bag pressure diagrams](#)

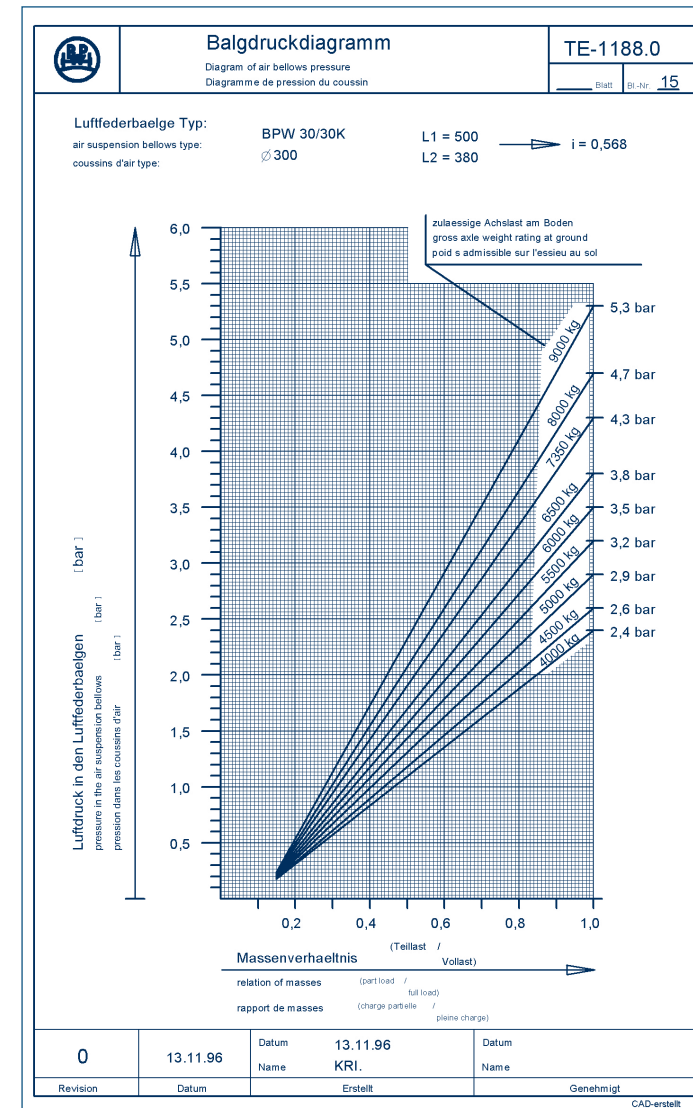

4.2.15 Characteristic curves and data sheets on My BPW | Air bag Data Sheets EA

BPW provides a comprehensive collection of data sheets for its air suspension running gear on its website (My BPW). These data sheets describe the most economical solutions according to technical requirements.

The weight tables are below the ride height overview. The centre of gravity heights stated for the trailer are limited by the mechanical tensions of the running gear components. This does not affect the rolling stability of the running gear.

The "Required characteristics" table describes the recommended uses in the on-road and off-road categories. The suitable air suspension programmes (EA, AL II or SL) are specified, based on the required axle load. Another table describes the permissible combinations of trailing arm and axle beam.

The configuration sheets are sorted according to ride height, axle load, brake type and size and air bag design (see above for an example). Self-steering axles are described separately. The last sheets describe the axle lift devices.

The designation of data sheet page number and row clearly defines an air suspension design. The axle executions shown, including tyre recommendation, refer to the common standard. Special versions which incur additional costs can be considered on request.

Airlight II

Air suspension axles with disc brake TS2 3709 (9 t)
Series ALO, air bag 30 / 30K

Ride height 390 - 565 mm
for trailer and semi-trailer

AL II - TS2.0
Sheet 1

DIRECTION OF TRAVEL

Only use authorised brake cylinders with internal seal max. Ø 191 mm
10 bolts M 22 x 1.5
DIN 74361 part 1 or part 3

Line	Series	Adjustable ride height FH				Total spring travel GF ¹⁾	Air bag type BPW	Shock absorber G2.21 ²⁾ ...	Hanger bracket			Shock absorber mounting		Brake position α			
		for single axles	for axle units	min. FH with axle raised	empty without air				loaded without air	ST	C	E	D		F	Packer B	
1 ³⁾	AL0*	390 - 430	400 - 430	430	330	315	190	30K	22.83.02	164	86	240	83	70	35	---	20°
2	AL0*	420 - 470	430 - 470	460	360	345	190	30K	22.83.02	268	80	258	83	90	35	---	20°
3	AL0*	450 - 510	460 - 510	490	390	375	220	30	22.88.02	268	80	258	83	90	35	---	20°
4	AL0*	500 - 565	510 - 565	540	440	425	220	30	22.88.02	350	100	300	100	100	150	40	20°

¹⁾ Lifting heights acc. to TD1242.0
²⁾ The packer is not included in supplied package.
³⁾ Only suitable for semi-trailers/Centre axle drawbar trailer
 LightTube possible

Axle type	Track SP with axle type		Spring centre FM		Air bag centre BM		Tyres recommended	
	...9010	...9008	V = 20	V = 60	10 bolts	8 bolts	10 bolts	8 bolts
SKHBF... 9010	2040	---	1200 ⁴⁾	1160	1080	385/65 R22.5	---	---
	---	---	1300 ⁴⁾	1260	1180	385/55 R22.5	---	---
	2095	---	1300 ⁴⁾	1260	1180	385/65 R19.5 ⁵⁾	---	---
	2140	---	1400 ⁴⁾	1360	1280	445/45 R19.5 ⁵⁾	---	---
SKHBF...9010 / 9008	2040	2045	1200 ⁴⁾	1160	1080	385/65 R22.5	385/65 R19.5 ⁵⁾	---
	2095	2100	1300 ⁴⁾	1260	1180	385/55 R22.5	435/60 R19.5 ⁵⁾	---
	2140	2145	1400 ⁴⁾	1360	1280	445/45 R19.5 ⁵⁾	---	---
	1820	1825	900	860	780	---	---	---
SKHZF...9010 / 9008	1880	1885	980	940	860	275/70 R22.5	265/70 R19.5	---
	1920	1925	980	940	860	---	---	---
	---	---	---	---	---	---	---	---

The adjustable ride heights (vertical distance between the centre of the axle and upper edge of the hanger bracket) are stated separately for single axles (for single axle trailers, but also for turntable drawbar trailers) and multi-axle units. A greater minimum ride height is recommended for them to accommodate 10 mm additional upward travel. It is required due to the potential vehicle tilt (+/- 1°).

If an axle lift device is to be installed, the distance must not be less than the adjusted minimum ride heights to ensure that there is sufficient space for the stroke.

(recommendation 100 mm). "Empty without air" describes the minimum ride height when the supporting air bags are in an unpressurised condition in an empty vehicle. The "loaded without air" ride height value is 15 mm lower due to the mechanical deformation of the components in a fully loaded vehicle. The overall spring deflection is determined by the air bag and describes the vertical spring deflection of the axle between the "empty without air" ride height and maximum achievable downward travel.

[Data sheets](#)
[AL II - SN.0](#)

[Data sheets](#)
[AL II - TS2.0](#)

[Data sheets](#)
[AL II - SN.0-R](#)

[Data sheets](#)
[AL II - TS2.0-R](#)

BPW-AG 36052402e – Version 1.2

243

4.3 Mechanical suspension ECO Cargo VB

4.3.1 Notes, features, series | Notes on content

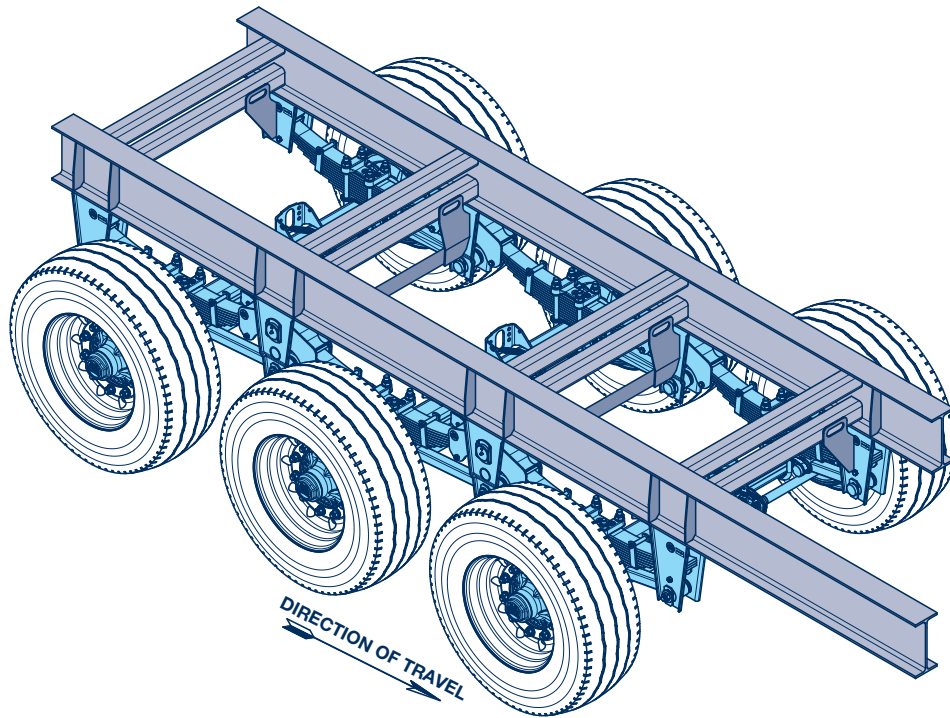

Overview of the series with mechanical suspension
[see chapter 1.2.6](#)

With this chapter we would like to present the technical guidelines of the design and give installation recommendations.

Please note that the drawings in the guidelines are examples only and dimensions depend exclusively on the vehicle type and its operating conditions. This data is only known to the vehicle manufacturer who must incorporate it in their design.

The safety factors for the constructional design of the vehicle frame and substructure must be defined by the vehicle manufacturer.

Detailed design data of BPW suspension units, such as dimensions, spring deflections, etc., can be found in the technical documentation (standard programme and offer drawings).

The warranty shall lapse if installation of the BPW axle system does not correspond to technical guidelines as per relevant BPW installation instructions.

4.3.1 Notes, Features, Series | Features, Series

- For axle loads of 9 t to 12 t (light series, 76 mm wide springs) and from 14 t to 20 t (heavy series, 100 mm wide springs)
- Deployable with one to three axles, and four-axle suspensions on consultation with BPW
- Available with parabolic springs (up to 12 t) or multi-leaf springs (up to 20 t)
- Static axle load distribution via equalising beams
- Equalising beams supplied in maintenance-free rubber-steel bushings (9 t to 14 t) or high-quality, durable bronze bushings (9 t to 20 t)
- Low-wear, replaceable spring sliders
- Precise axle-guidance through horizontally-arranged connecting rods
- Easy axle alignment through one rigid and one adjustable connecting rod per axle, adjustable hanger brackets in the ECO Cargo VB
- Maintenance-free connecting rods in rubber-steel bushings
- Stabilizers available for vehicles with a high center of gravity
- Tri-axle suspension can be combined with a BPW rear steering axle LL (up to an axle load of 14 t)
- Hanger brackets with good weldability
- Front hanger brackets available with drawbar connection
- HD/HDE versions also feature thick-walled spring sliders made from hardened and tempered steel alloy

Leaf spring installation

- Series **VB** Leaf spring above the axle beam / overslung
- Series **VB HD** Leaf spring above the axle beam / overslung
- Series **VBT** Leaf spring below the axle beam / underslung

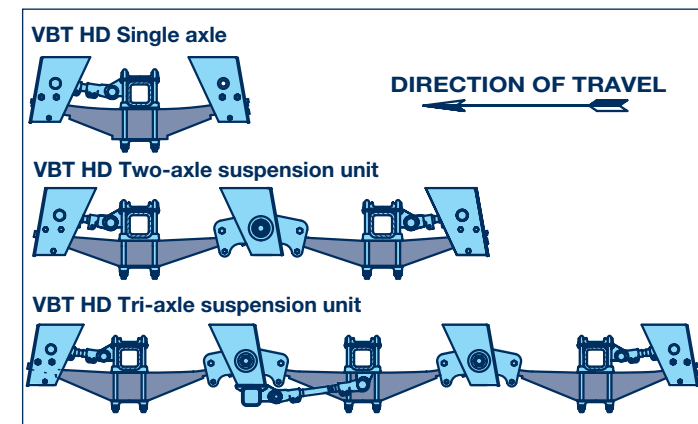
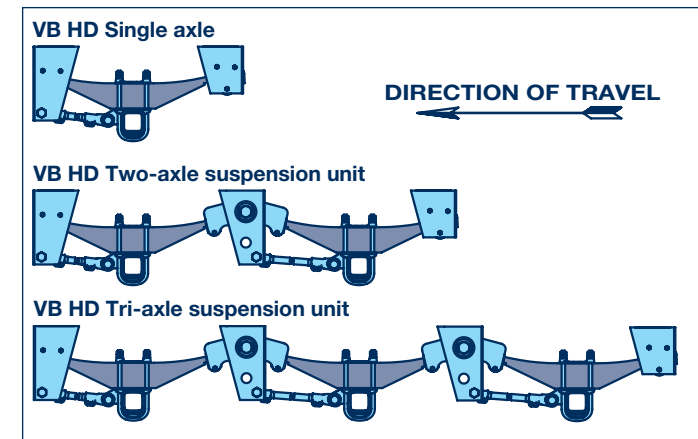
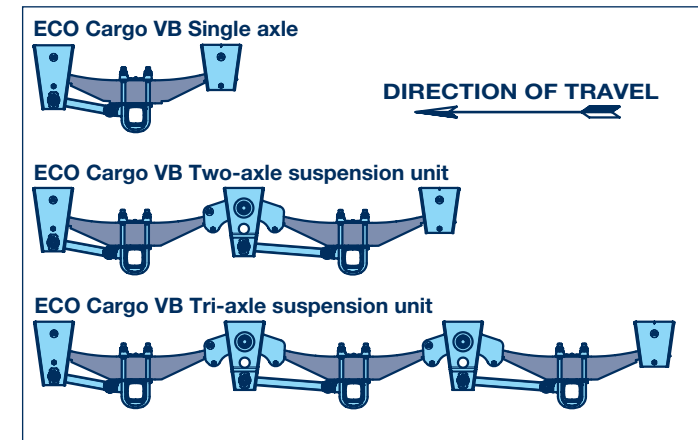

4.3.1 Notes, Features, Series | Design Description

General

Mechanically suspended axles from BPW's VB series can be installed as single axles or as multi-axle suspension units. The axles are connected to the vehicle frame by connecting rods, hanger brackets and equalising beams.

Longitudinal forces

Longitudinal forces are transmitted by connecting rods between the axle and hanger bracket. Thanks to their horizontal arrangement, BPW connecting rods guarantee precise axle guidance for minimal tyre wear.

Vertical forces

Vertical forces are transmitted into the vehicle frame by the hanger brackets and equalising beams.

Lateral forces

The lateral forces are exclusively transmitted into the vehicle frame via the hanger brackets. They must therefore be braced accordingly with gussets, so as not to exceed the permissible torsion loads of the frame's longitudinal beam.

Additional features

Further features and system solutions are contained in the BPW technical documentation.

4.3.2 Function, ABS, axle loads

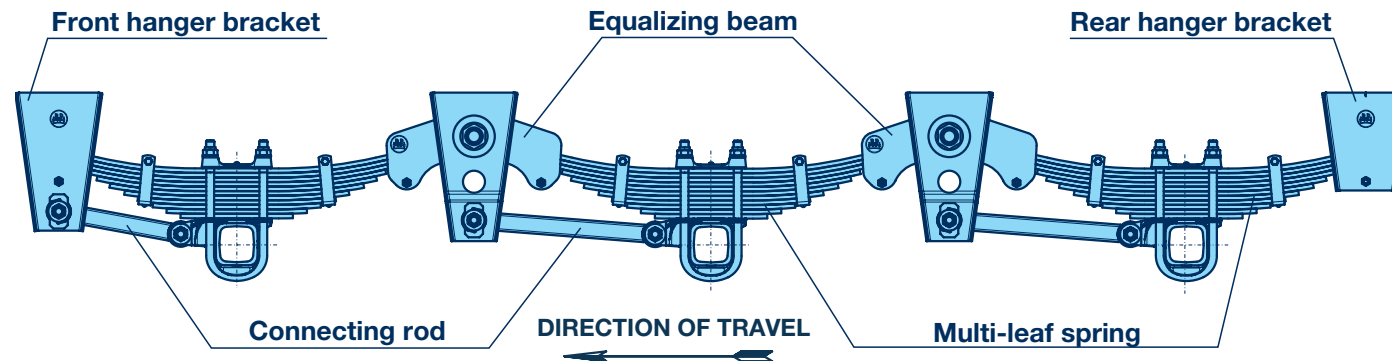

BPW VB suspension units are equipped with parabolic or multi-leaf springs. Depending on the version, parabolic springs have two or three parabolic rolled spring layers. The efficient use of material enables them to combine low weight with a low height. Multi-leaf springs (trapezoidal springs) contain a stack of spring layers with a constant cross-section and graded lengths to give a trapezoidal shape. They are characterised by their robustness and good default driving properties as well as the ease of replacing individual spring layers. The ends of the leaf springs are mounted on sliding bearings using spring slides both in the connecting pieces and in the equalising beams. This enables unhindered "lengthening" in operation.

The axles are guided by separate connecting rods, which are adjustable in order to enable the alignment to be set easily (for ECO Cargo VB, adjustment is via the hanger bracket, while ECO Cargo VB HD features adjustable connecting rods on one vehicle side).

BPW leaf suspension systems are designed to offer self-damping and do not need any additional shock absorbers.

Parabolic spring



Multi-leaf spring



4.3.2 Function, ABS, axle loads | Axle / brake load balancing

In the case of multi-axle suspension units, the middle hanger brackets have pivoting equalising beams. The spring ends slide-mounted in the equalising beams achieve static axle load equalisation (all-over distribution of axle load when stationary and on the move).

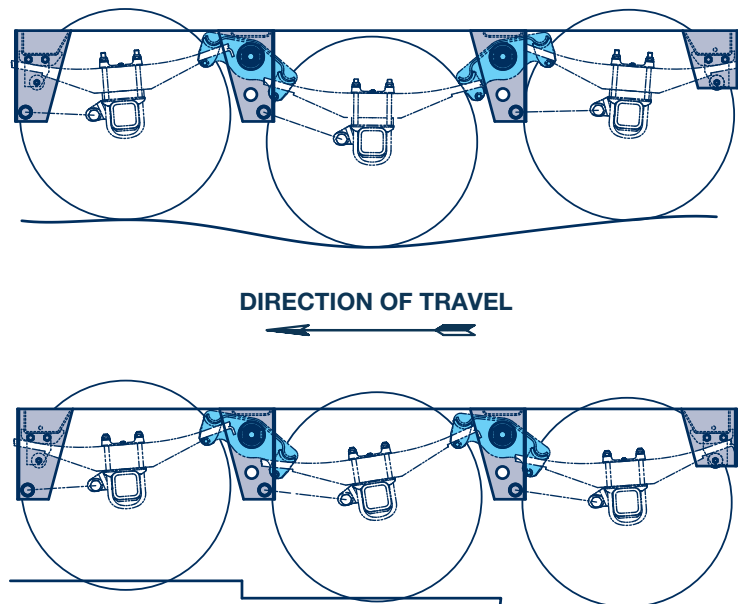

The design causes that no dynamic axle load equalisation is provided (uneven axle load distribution when braking).

The front axle tends to unload and – if all axles are configured consistently – cause the front axle to overbrake. There is the option to configure the axles differently (brake cylinder dimension and/or lever length). We can provide a brake calculation for your vehicle concept on request.

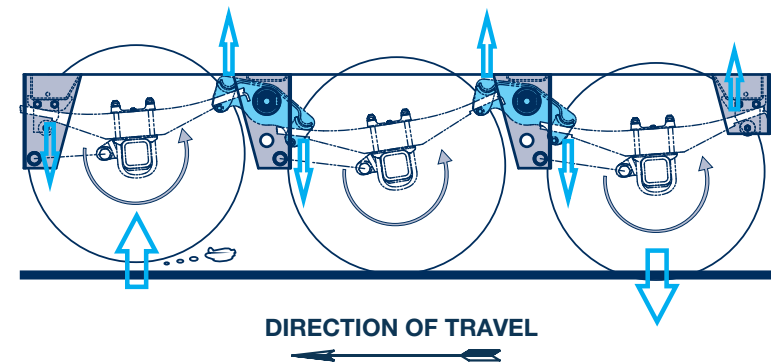

We recommend the following ABS sensing:

Configuration			
Two-axle suspension unit	recommended	Front and rear axle	4S / 2M or 4S / 3M
	simplified	Front axle	2S / 2M
Tri-axle suspension unit (no steering axle)	recommended	Front and rear axle	4S / 2M or 4S / 3M
	simplified	Central axle*	2S / 2M

* As the ride height of the centre axle is least affected by pendulum arm movements, this axle is directly suitable for height compensation

4.3.2 Function, ABS, axle loads | Axle / brake load balancing

Superstructure inclination

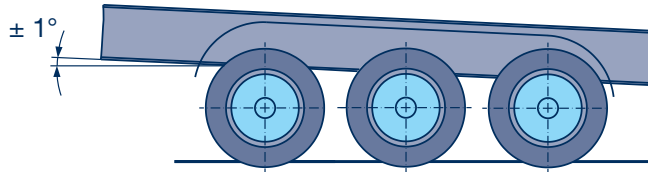

Due to the limited equalisation paths, the maximum body tilt of the semi-trailer may not exceed $\pm 1^\circ$.

Otherwise, it should be expected that axle loads will exceed limitations significantly on uneven terrain, which could result in damage to components.

Axle loads

The axle loads given are maximum values on the ground up to 105 km/h. For vehicles with a lower speed limit, the following axle load increases are permissible:

V max. 40 km/h + 10 %

V max. 25 km/h + 25 %

V max. 10 km/h + 40 %

For an axle load increase of over 10 %, reinforced multi-leaf springs must be used.

For higher loads at lower speeds, confirmation from BPW is required.

4.3.3 Axle beam welding guidelines

General

When installing trailer axles, it may be necessary to subsequently weld components on to the axle beam.

BPW axles are made of materials that can be welded. The axle beams do not have to be pre-heated before welding.

The carrying capacity and faultless operation of BPW axles are not impaired by welding, if the following points are complied with.

Welding process

- Gas shielded arc welding
Weld wire quality G 4 Si 1 – EN ISO 14341-A
- Manual arc welding
Stick electrodes E 46 5 B 32 H 5 – EN ISO 2560-A
- Mechanical quality values must correspond to the basic material S 420 or S 355 J 2
- Single-sided fillet weld: weld quality according to DIN EN ISO 5817 evaluation group C
- Sheet thickness 6 mm -> seam thickness a4 ▽
Sheet thickness 8 mm -> seam thickness a6 ▽
- Avoid end craters and undercuts!
- Functional surfaces are free from weld spatter.

Material: S 420 and S 355 J 2

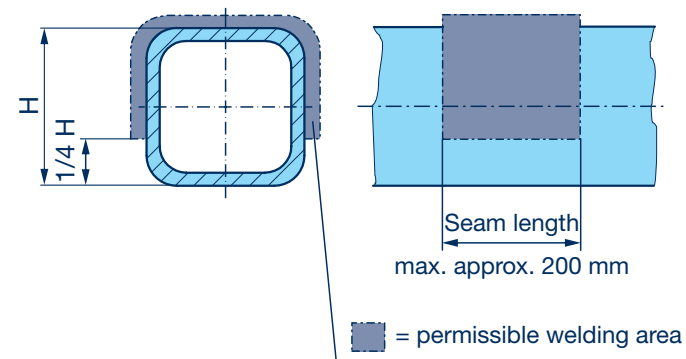

Welds must not result in any impermissible changes in the camber and toe-in direction of the axle.

Therefore, compliance with the welding zones and weld seam lengths (see sketch) is mandatory.

- Do not weld in the lower area of the axle beam (bottom)!
- For all welding activities, the springs, spring U-bolts and all other sensitive components must be protected against flying sparks and welding spatter.
- The earth terminal should under no circumstances be attached to the trailing arm, spring U-bolt or hub.
- It is not permitted to weld the springs!
- Heating the hanger brackets for straightening work is not permitted!
- Use new bolts and lock nuts when renewing hanger brackets.

4.3.4 Installation and bracing

BPW ECO Cargo VB units are usually delivered unassembled, i.e. axles, hanger brackets and equalizers separately on pallets. These units are installed in the back position of the vehicle frame.

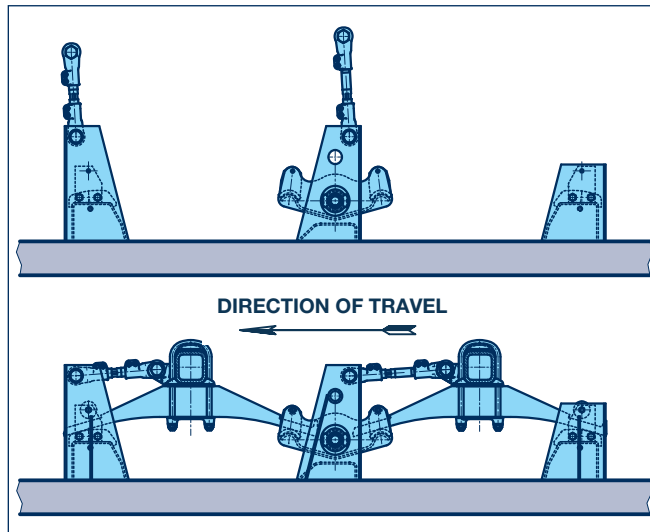

Assembly

There should be at least a 30 mm gap between the chassis and the tires. Track width, tire and side member dimensions must be observed in this respect.

The support spacing in the transverse direction must be manufactured within the tolerance range of the spring center distance (0, +2) to avoid distortions in the axle assembly. Check the track and correct if necessary after welding on the hanger brackets or mounting the axles (see Alignment, [see chapter 3.2](#)).

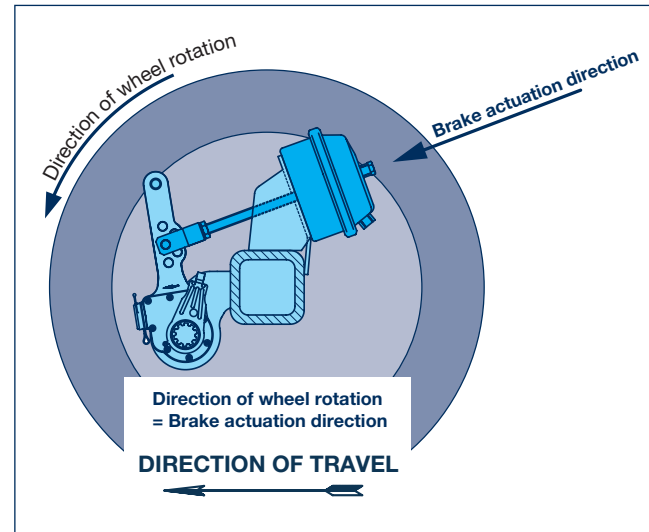

Mounting direction of the axles:

The brake actuation direction (direction of rotation of the brake camshaft) must match the direction of wheel rotation during forward travel.

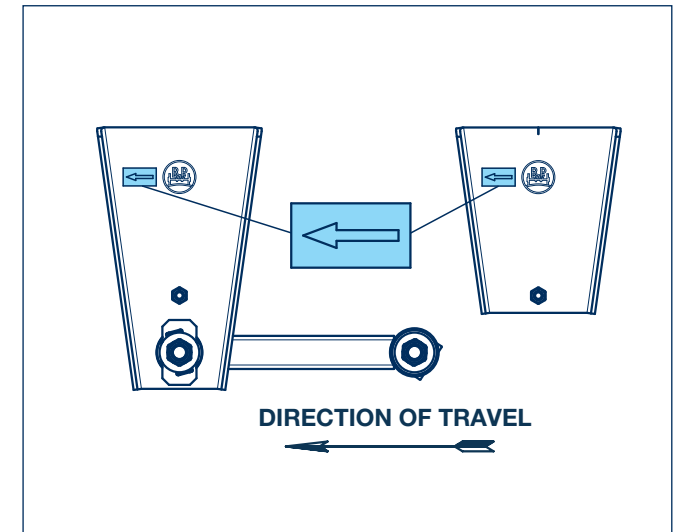

Hanger brackets in ECO Cargo VB

The front and rear hanger brackets in the ECO Cargo VB must be welded onto the chassis according to the direction of travel. A corresponding sticker is present on each hanger bracket.

4.3.4 Installation and bracing

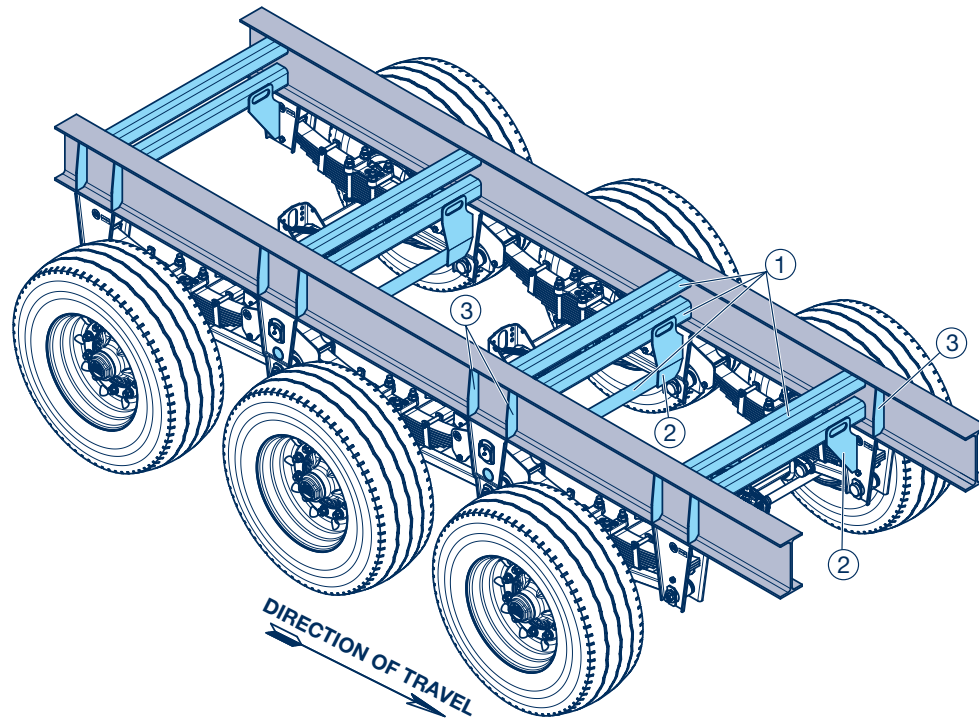

Fig.: ECO Cargo VB Tridem suspension

General

Please note that the bracing suggestions are examples only and dimensions depend exclusively on the vehicle type and its operating conditions. This data is only known to the vehicle manufacturer who must incorporate it in their design.

1. Crossmember

The transverse forces encountered in curve travel are transmitted as bending forces, via the hanger brackets and gusset plates, into the crossmember, which has to be dimensioned accordingly.

For vehicle frames flexible against longitudinal torsion (i.e. for flatbed, low-loading or some dump trailers), torsion-flexible crossmembers (with open profiles) must be used (except for connecting rod of central hanger bracket). The connection of the crossmembers to the longitudinal members should be made via the ribs and not via the flanges.

For vehicles with longitudinally torsion-resistant frames (tanker, silo and box body trailers), torsion-resistant crossmembers may also be used.

2. Gusset plates

The gusset plates serve to connect the hanger brackets to the crossmembers in order to distribute the transverse forces. Suitable designs are described in the following.

3. Vertical profiles

Vertical profiles, such as ribs, provide local reinforcement to the longitudinal beam and are recommended in the hanger bracket area.

4.3.4 Installation and Bracing | Example: Reinforcement instructions ECO Cargo VB two-axle suspension unit (is not supplied by BPW)

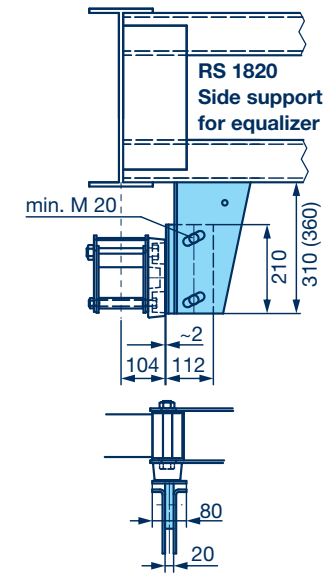
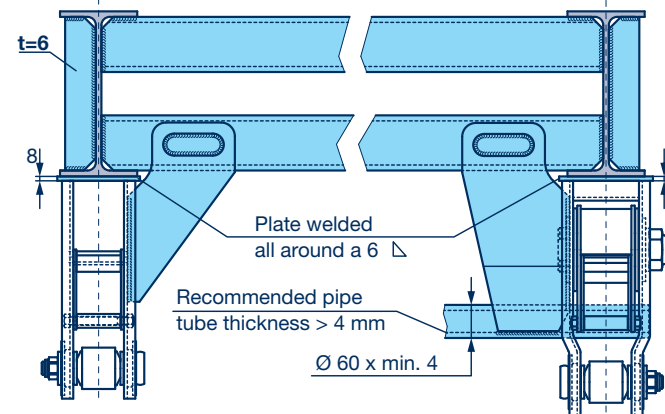
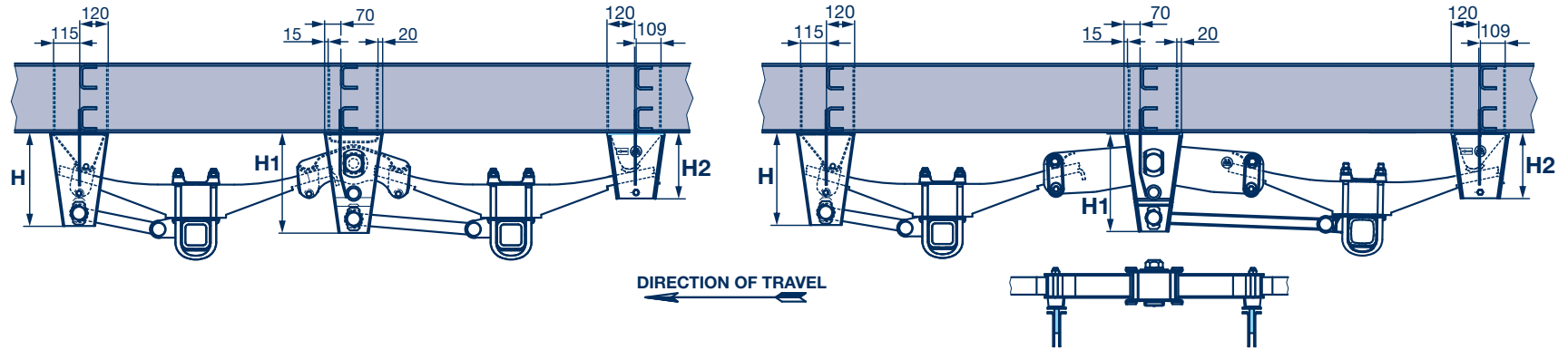

Bracing of the hanger brackets

Hanger bracket height	L	L1
H	395	325
H1	425	260
H2	280	325

Bracing of the front and rear hanger brackets

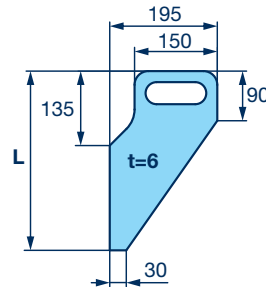

Bracing of the centre hanger brackets

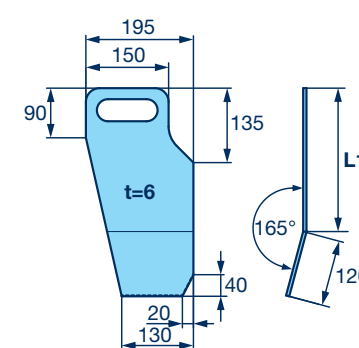

4.3.4 Installation and bracing |

Example: Reinforcement instructions two-axle suspension unit with parabolic springs

(is not supplied by BPW)

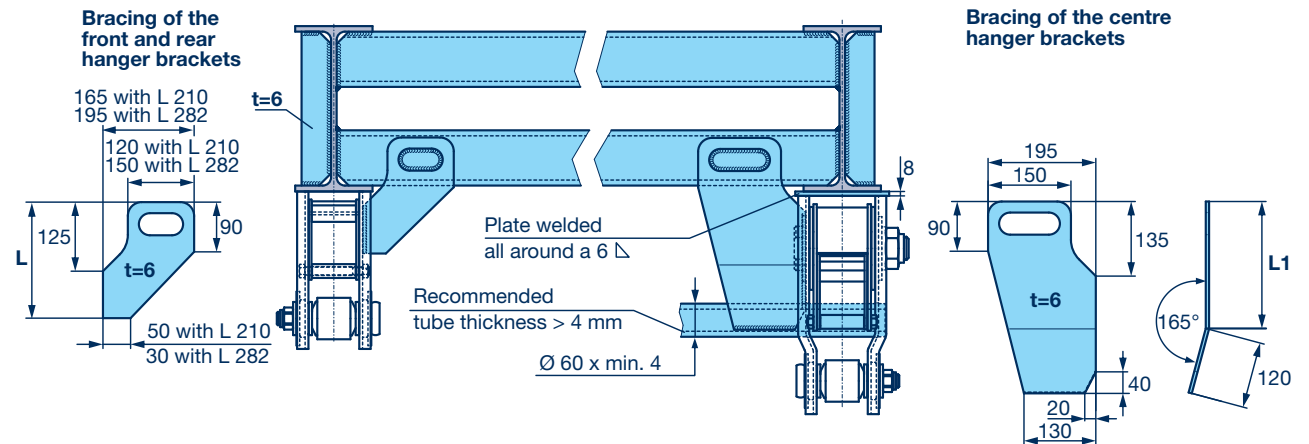
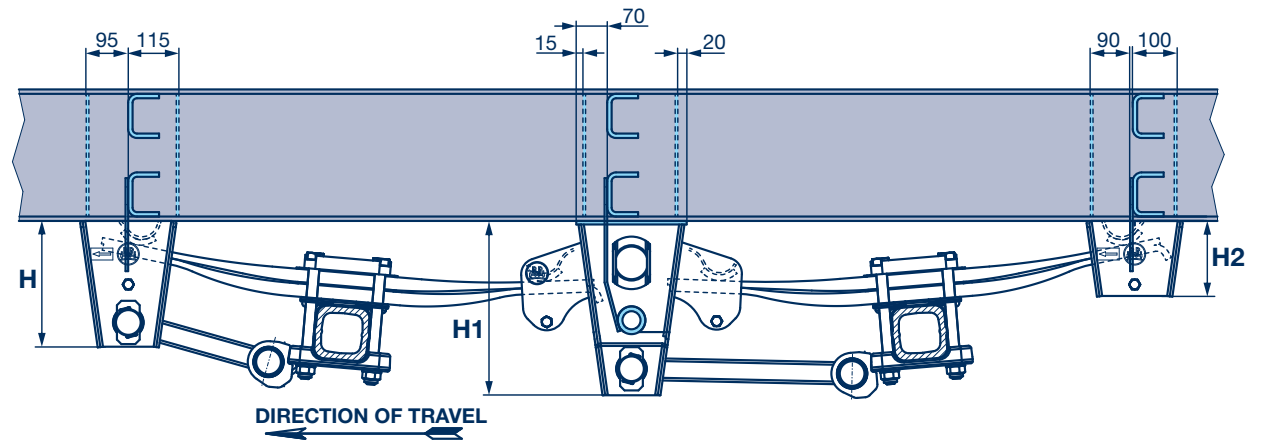

Bracing of the hanger brackets

Hanger bracket height	L	L1
H	285	210
	357	282
H1	395	230
H2	170	210
	242	282

4.3.4 Installation and bracing | Example: Reinforcement instructions ECO Cargo VB HD

(is not supplied by BPW)

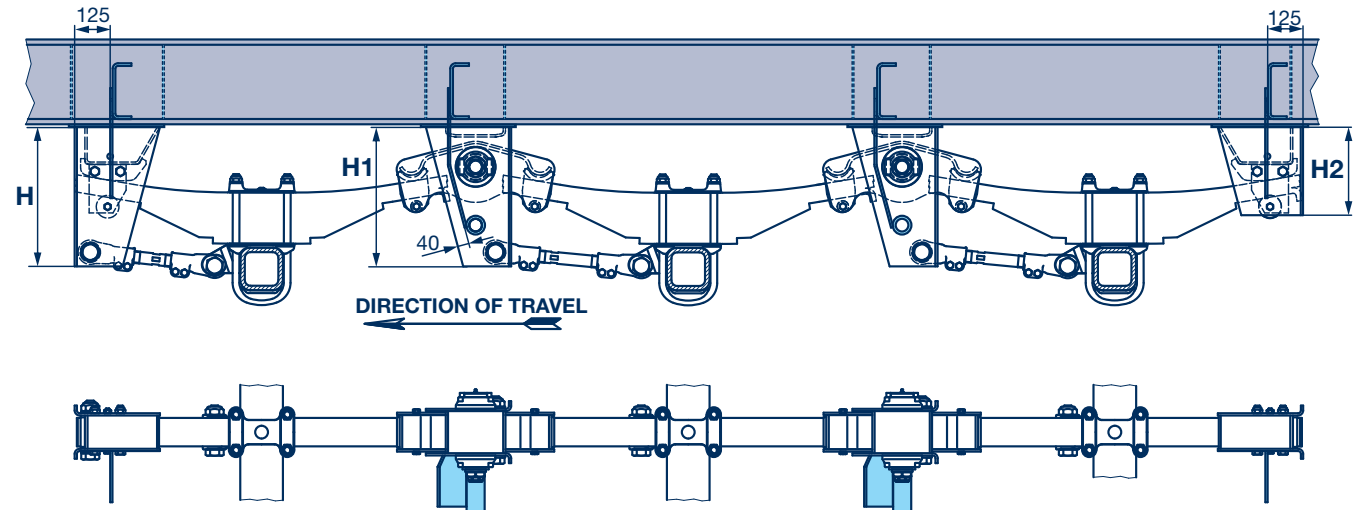

Bracing of the hanger brackets

Hanger bracket height		L	L1
H	490	382	
H1	490		255
H2	310	382	

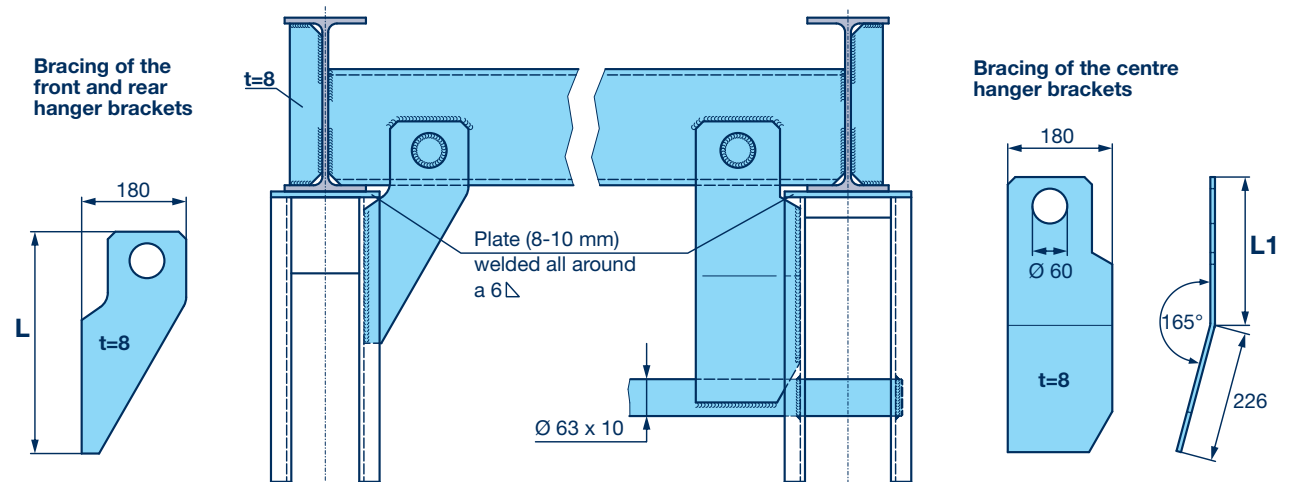

4.3.4 Installation and bracing |

Example: Reinforcement instructions ECO Cargo VBT three-axle suspension unit

(is not supplied by BPW)

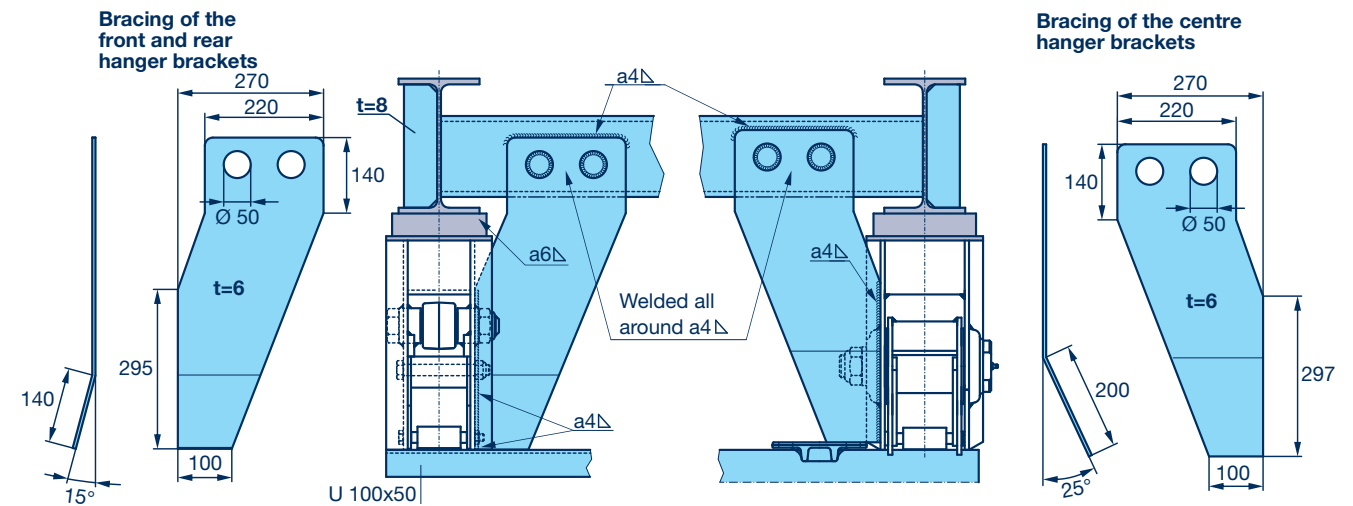
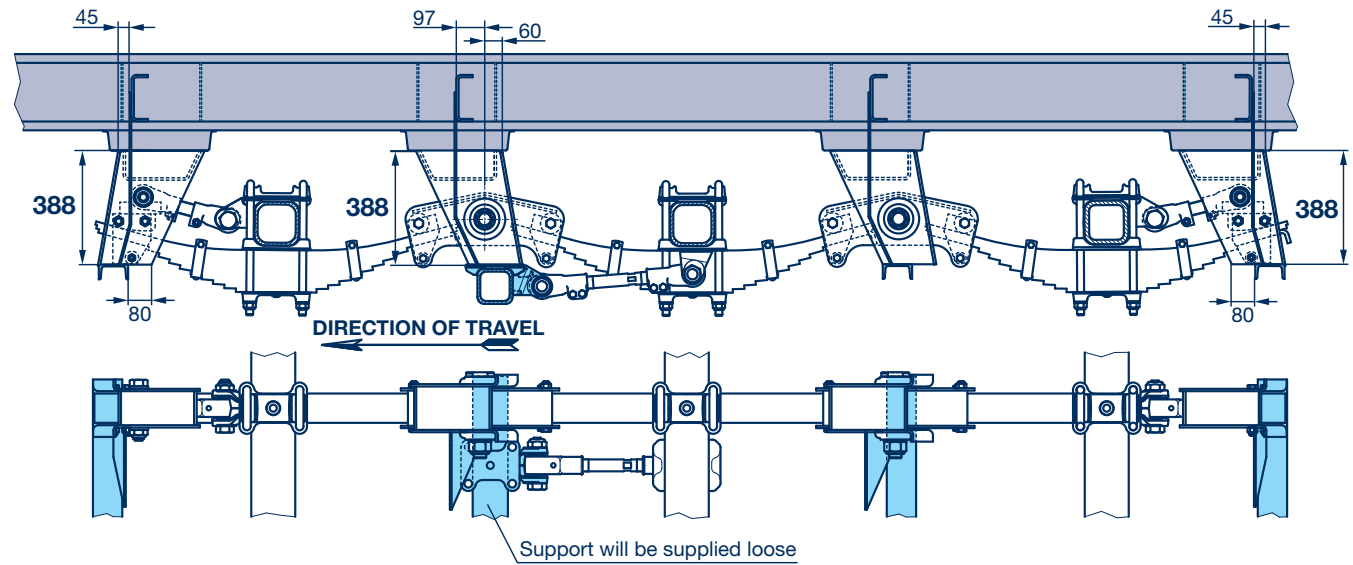

4.3.5 U-stabilizer

BPW VB suspension with U-stabiliser (VBU)

In the case of special roll stability requirements, e.g. for vehicles with a high centre of gravity, BPW VB suspensions can additionally be equipped with one or more stabilisers.

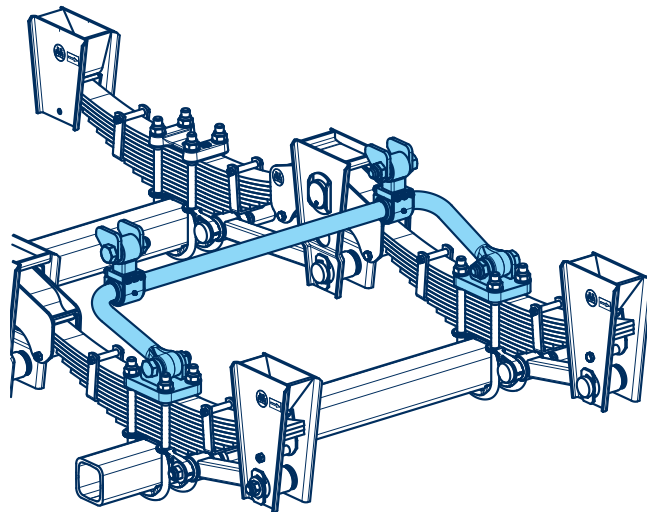

ECO Cargo VBU

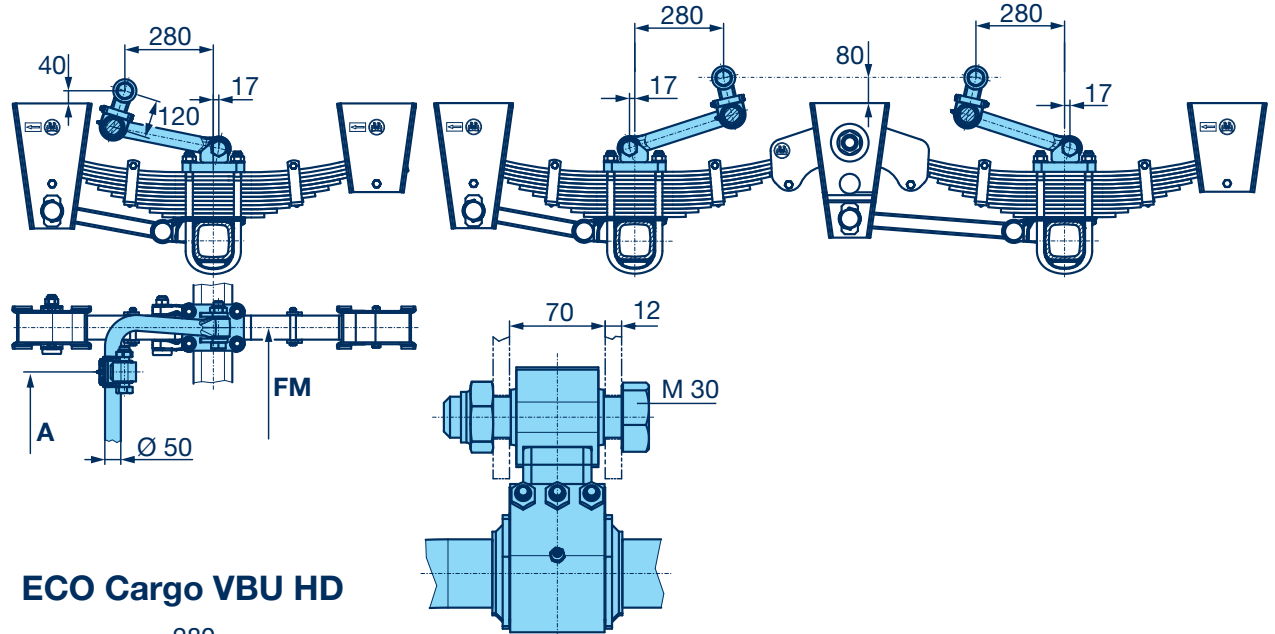

ECO Cargo VBU HD

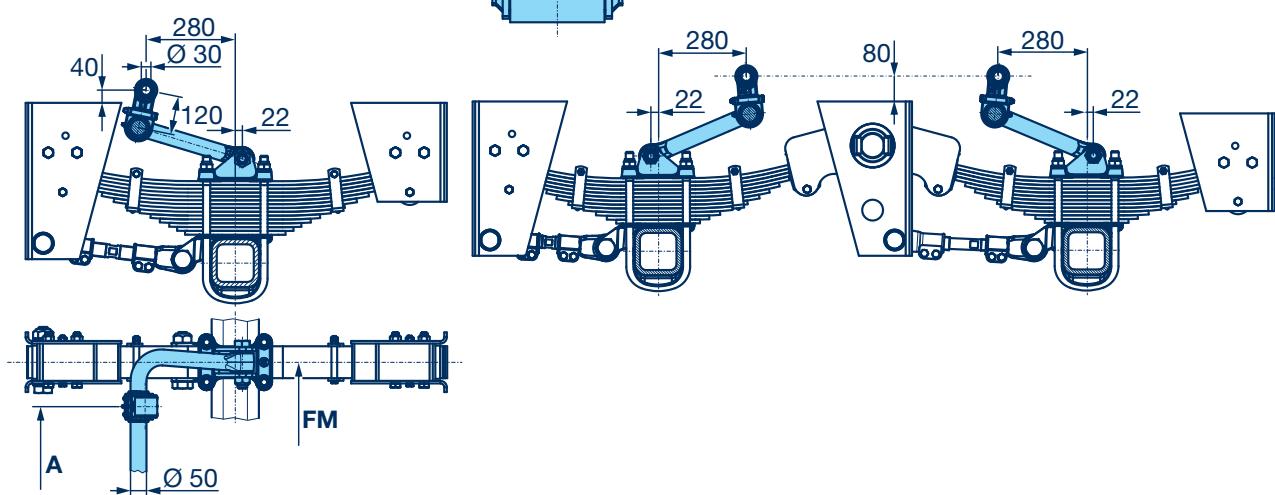

4.3.6 Alignment | Alignment ECO Cargo VB

The maximum possible wheel base correction per axle for adjustable hanger brackets (ECO Cargo VB) is ± 5 mm.

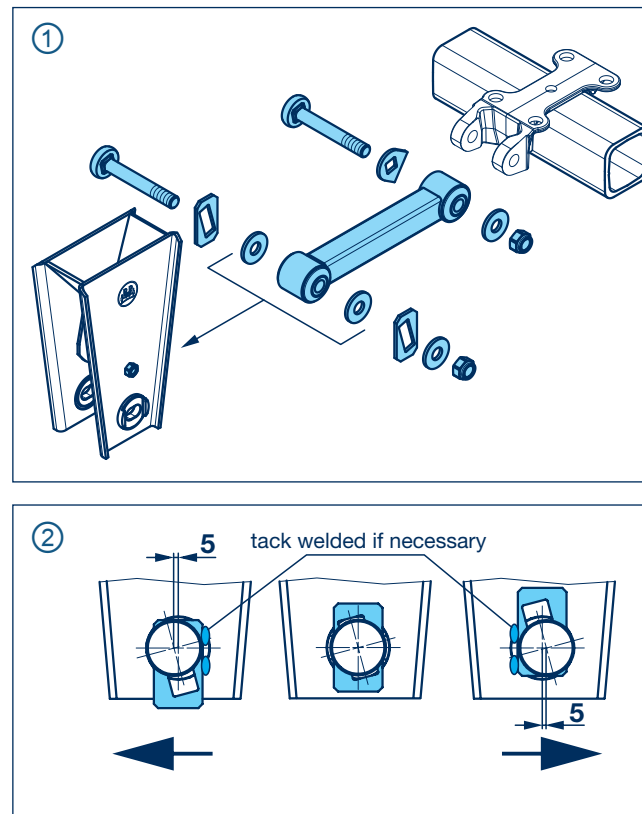

Alignment

1. Raise and support the vehicle frame.
2. Loosen the M 24 (SW 36) lock nut of the connecting rod attachment (Fig. ①).
3. For tandem and tridem: Align the front axle first, then the other axles.
4. Slide the adjusting plates on both sides, as required, upwards or downwards with light hammer blows (Fig. ②).
5. Make sure the inner and outer adjusting plates on each hanger bracket are adjusted symmetrically!
6. Tighten the lock nut M 24 (SW 36) to the specified torque.
M = 650 Nm (605 - 715 Nm)
7. For difficult road conditions, the adjusting plates can be tack welded (Fig. ②).
8. Remove supports from underneath the vehicle.

4.3.6 Alignment | Alignment ECO Cargo VB HD / VBT

One rigid and one adjustable connecting rod enable easy alignment.

For some suspension unit versions, also two adjustable connecting rods per axle are used.

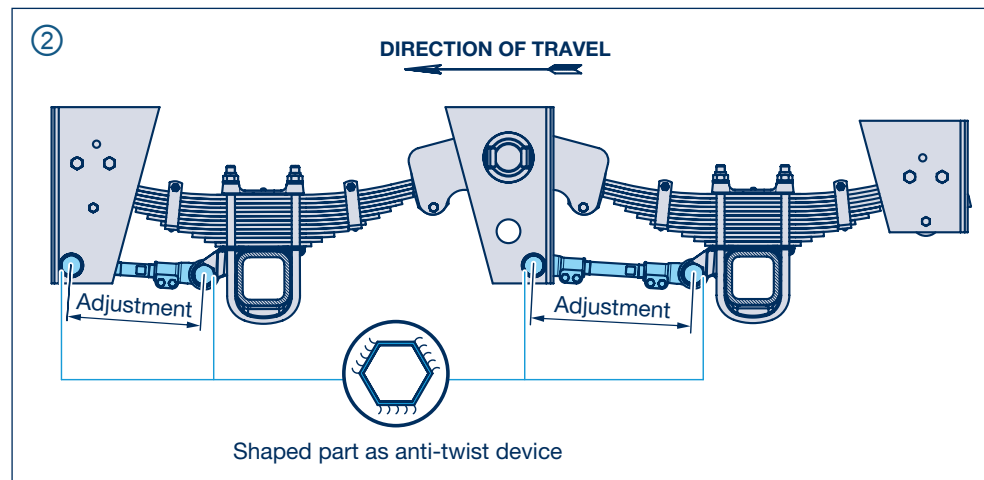
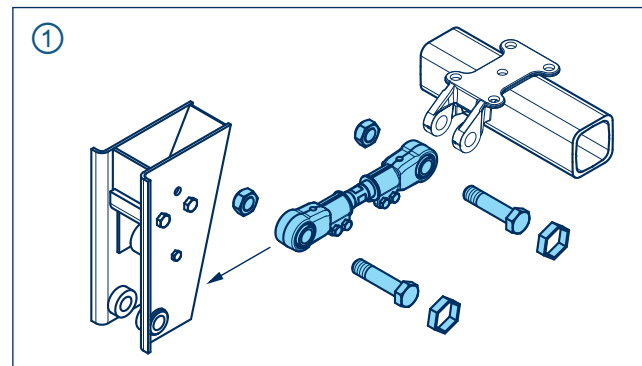

Track alignment

1. Raise and support the vehicle frame.
2. Loosen locking nuts M 12 / M 14 from the connecting rod clamp connections (Fig. ①).
3. For tandem and tridem: Align the front axle first, then the other axles.
4. Align the axle by turning the adjusting shaft (left-right thread) (Fig. ②).
5. Tighten locking nuts M 12 / M 14 to the specified torque.

M 12	M = 66 Nm
M 14	M = 140 Nm
6. Remove supports from underneath the vehicle.
7. Weld on the shaped part to prevent twisting.

4.3.6 Alignment | Alignment with laser measuring system

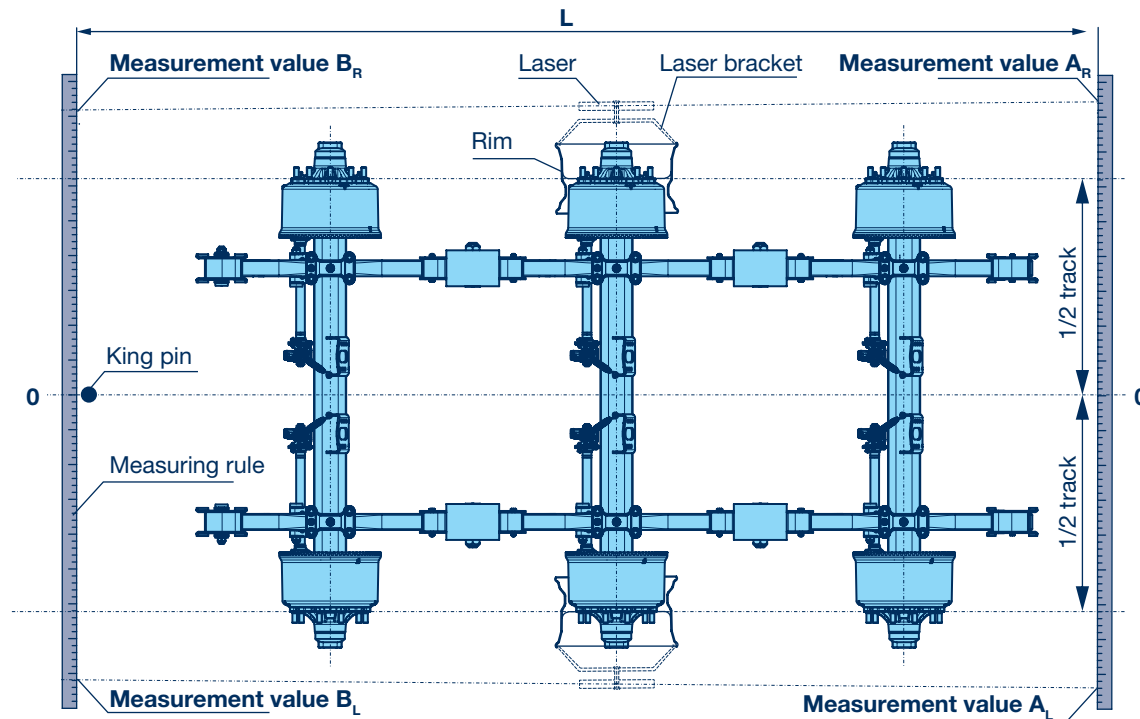

If laser measuring systems are used, care must be taken to ensure that the axle is aligned **horizontally** in order to obtain a correct measurement as otherwise the camber values will affect the result. It is assumed that the vehicle does not carry any loads.

The operating and setting instructions of the system manufacturer must be adhered to!

The maximum possible wheelbase correction per axle is ± 5 mm for adjustable hanger brackets (see track settings with adjustable hanger

brackets).

During the alignment, the tracking values of the right and left wheel side must be averaged for each axle.

Instead of measuring all three axles using the laser method, it is also possible to only align the mid-axle using the laser method.

The front and rear axle are positioned relatively to the mid-axle using suitable axle centre distance devices (like during conventional tracking).

Calculation of the toe-in and toe-out settings:

$$\frac{(A_R - B_R) + (A_L - B_L)}{L} = \text{Axle track (mm/m)}$$

Positive value = toe-in

Negative value = toe-out

The total of the values is the toe-in/toe-out value of the axle and must be within the permitted tolerance range.

Target values (total axle track):

- Rigid axle
-1 ... + 5 mm/m
- Self-steering axle
0 ... + 4 mm/m (drum brake)

Note

The tracking tolerances defined by BPW must be maintained. Only by maintaining these tolerances low-wear operation of the vehicle can be assured. The tracking values are set for steered axles at the factory and the steering rod must not be adjusted.

4.3.6 Alignment | Conventional alignment check

To compensate for manufacturing tolerances, an axle alignment check must be conducted and any corrections made as necessary.

Semi-trailer:

Determine diagonal dimensions **A - B** and **A - C** for the front axle (reference axle) using comparative measurements and correct if necessary.

Check wheel base measurements **B - D** and **C - E** for the centre axle and **B - F** and **C - G** for the rear axle and correct if necessary.

Turntable drawbar trailer:

Determine diagonal dimensions **A - B** and **A - C** for the front axle (reference axle) using comparative measurements and correct if necessary.

Determine diagonal dimensions **A1 - D** and **A1 - E** for the centre axle using comparative measurements and correct if necessary.

Check wheel base measurements **D - F** and **E - G** for the rear axle and correct if necessary.

Semi-trailer

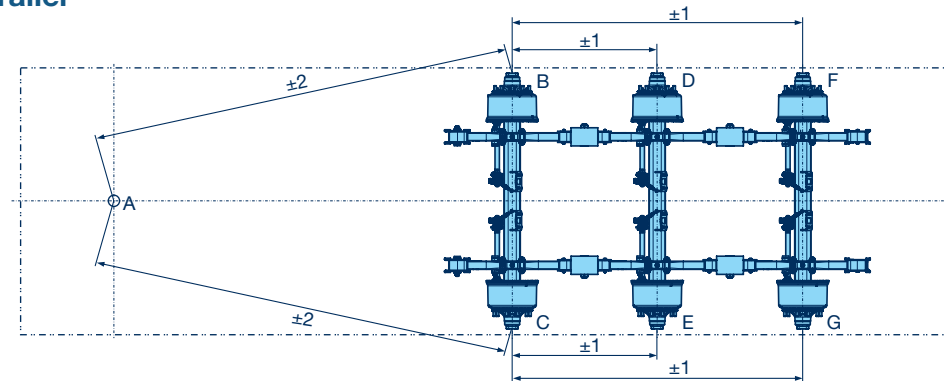

Turntable drawbar trailer

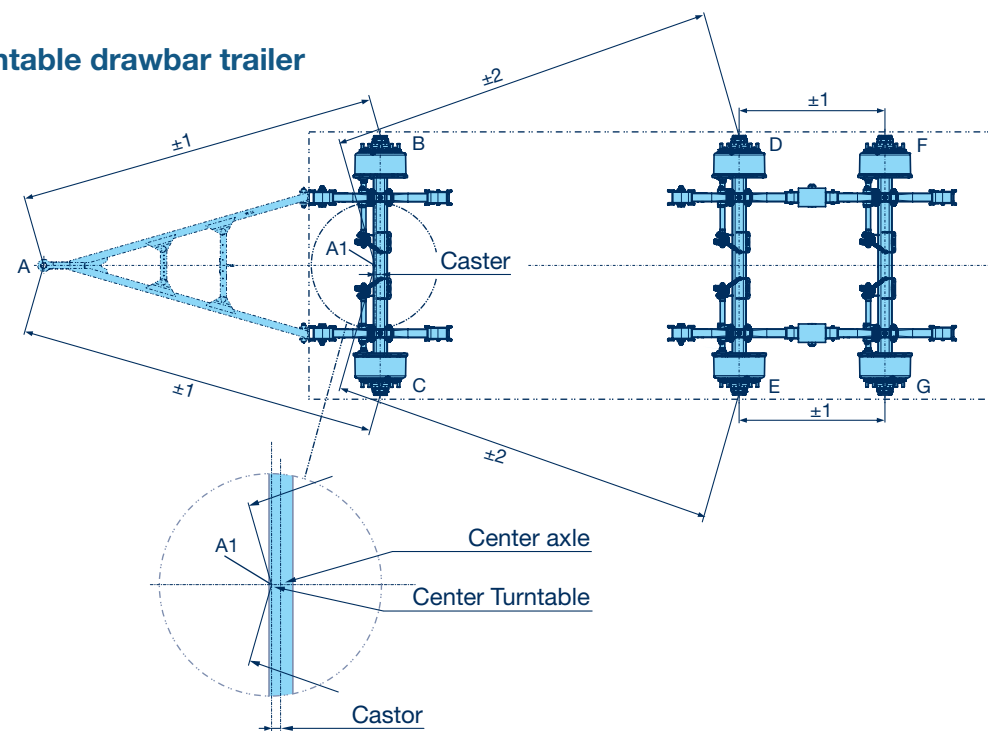

4.3.6 Alignment | Conventional alignment check

Measurement is generally carried out by means of the hub cap centre point (see illustration). It can also be carried out using suitable distancing devices or screwed-on calibration tubes.

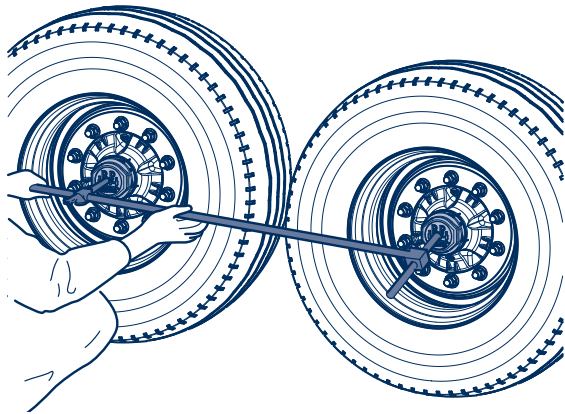

The triangle in the BPW logo is in the centre and can be used for holding a measuring tool.

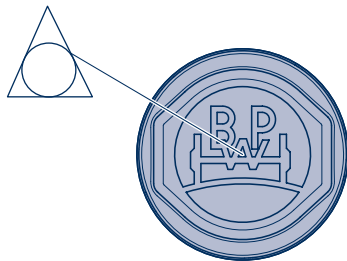

Note

This method only takes into consideration the axle distances but not the individual track values on the axle sides. This is sufficient for axles with optimal track values. This conventional method has a higher probability of incorrect measurements than the laser method ([see page no. 260](#)).

The measurement of smaller differences across greater lengths can be impacted by factors such as the elasticity in the measuring tool (manual force).

The tracking tolerances defined by BPW must be maintained. Only by maintaining these tolerances low-wear operation of the vehicle can be assured.

The tracking values are set for steered axles at the factory and the steering rod must not be adjusted.

4.3.7 Tightening torques

Area	Item	Attachment	Comment	Thread	SW	Tightening torque
Spring U-bolt	1.1	Spring U-bolt 1)		M 24-8.8	36	(600 - 650 Nm)
Leaf springs	2.1	Spring screw		M 16	24	163 Nm
	2.2	Nuts of the leaf spring clamps		M 12	19	66 Nm
Connecting rods	3.1	Lock nuts of the axle / connecting rods		M 24 x 2	36	650 Nm
				M 30	46	725 Nm
				M 36	55	1425 Nm
	3.2	Connecting rod clamping bolts		M 12-8.8	19	66 Nm
				M 14-8.8	22	140 Nm
Sliders / Supports	4.1	Attachment sliders / supports	ECO Cargo VB	M 14	22	140 Nm
			ECO Cargo VB HD, VBT	M 20	30	320 Nm
Equalizing beam bearing	5.1	Lock nuts on the equalizer arm bearing	ECO Cargo VB 9 - 12 t	M 42 x 3	65	1300 Nm
			ECO Cargo VB HD, VBT	M 48 x 3	65	1250 Nm
U-stabiliser	6.1	Attachment U-stabilizer		M 30	46	700 - 750 Nm
	6.2	Lock nuts of securing bolts for shaped plate		M 10-10.9	17	53 Nm

1) Apply grease to the threads of the spring U-bolts and nut contact surfaces.

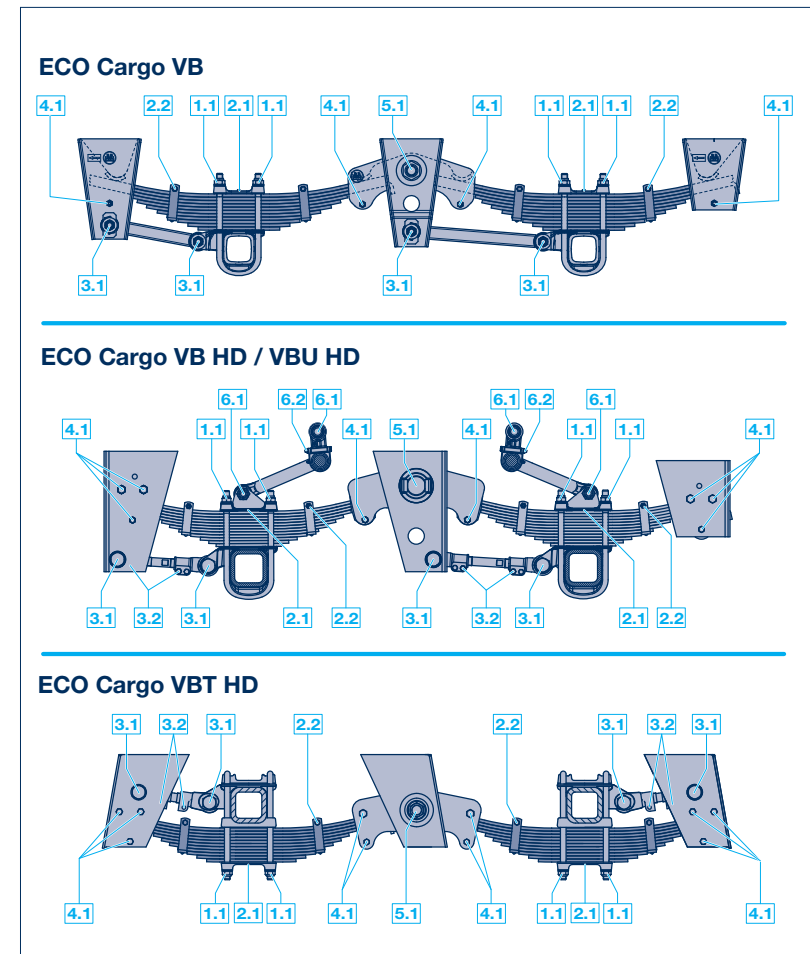

Attention: Suspension units with bronze bearings on the equalizing beams (**ME** and **HDE** models) must be lubricated with BPW ECO^UPlus grease before commissioning.

4.4 Mechanical suspension ECO Cargo W

4.4.1 Features and series

The mechanically suspended axle unit ECO Cargo W is suitable for heavy on- and off-road use up to 40 t unit load and is supplied fully assembled.

- Extremely robust, durable and low-maintenance design
- Easy installation due to screw connection to the vehicle frame, with mounting bracket in high or low version
- Very large axle load compensation travel (up to +/- 300 mm) due to pivot bearing on central support axle
- Multi-leaf springs in various axle load-dependent designs:
 - 90 mm spring width up to 12 t axle load
 - 120 mm spring width over 12 t axle load
 - Wheelbases 1400...1650 mm

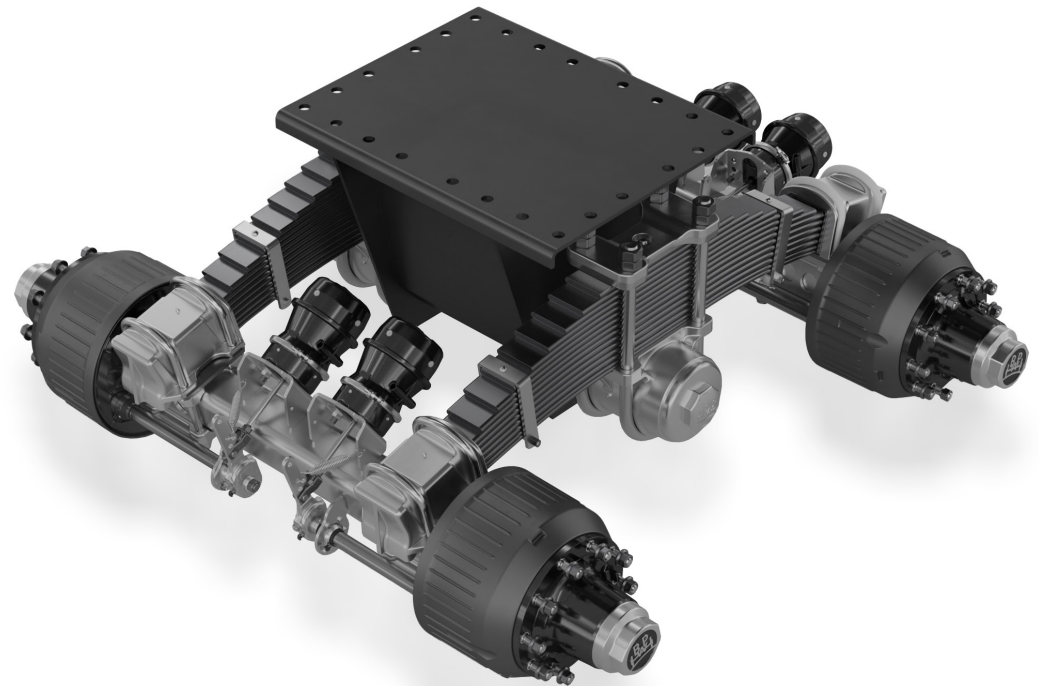

4.4.1 Features and series

As a **mounting bracket** for the assembly with the vehicle chassis, a low solution (left, two brackets between the springs) or a high one (right) is available.

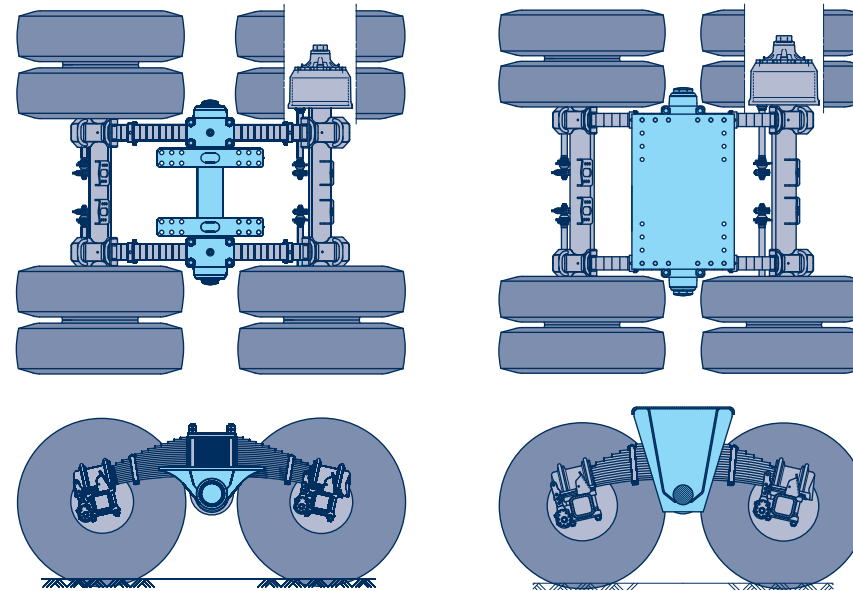

Multi-piece wheels are available as an option. In conjunction with segment-split rims (e.g. Trilex), these are often used in regions without a comprehensive workshop network. This makes it possible to change tires with simple tools without mounting equipment.

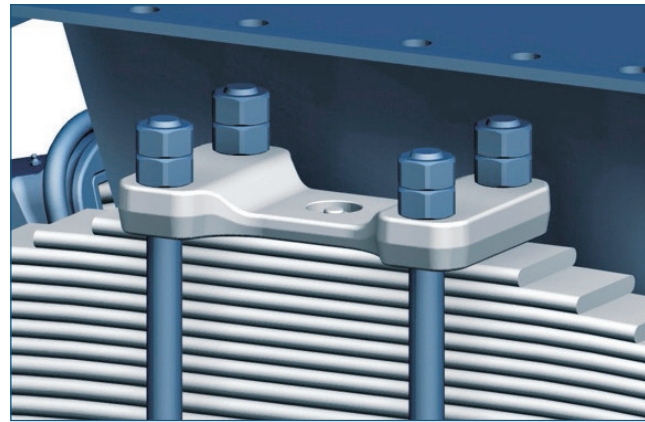

Leaf spring clamping by forged spring plates with high strength

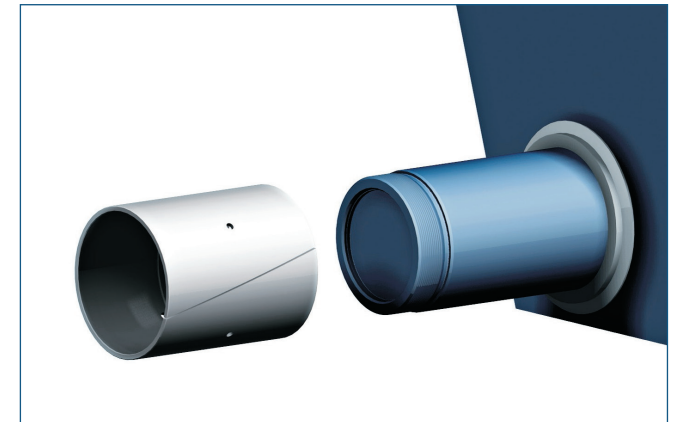

Support axle bearing with special low-maintenance bushings made of fiber-reinforced plastic (FRP), with best emergency running capability

4.4.2 Installation

The pendulum travel can reach up to ± 300 mm. Dynamic brake force compensation is not available due to the design (similar to VB).

The bolt-on level on the chassis must not exceed an unevenness of 2 mm in the longitudinal and transverse directions. Bolting with M30 - 8.8, $M = 1400$ Nm

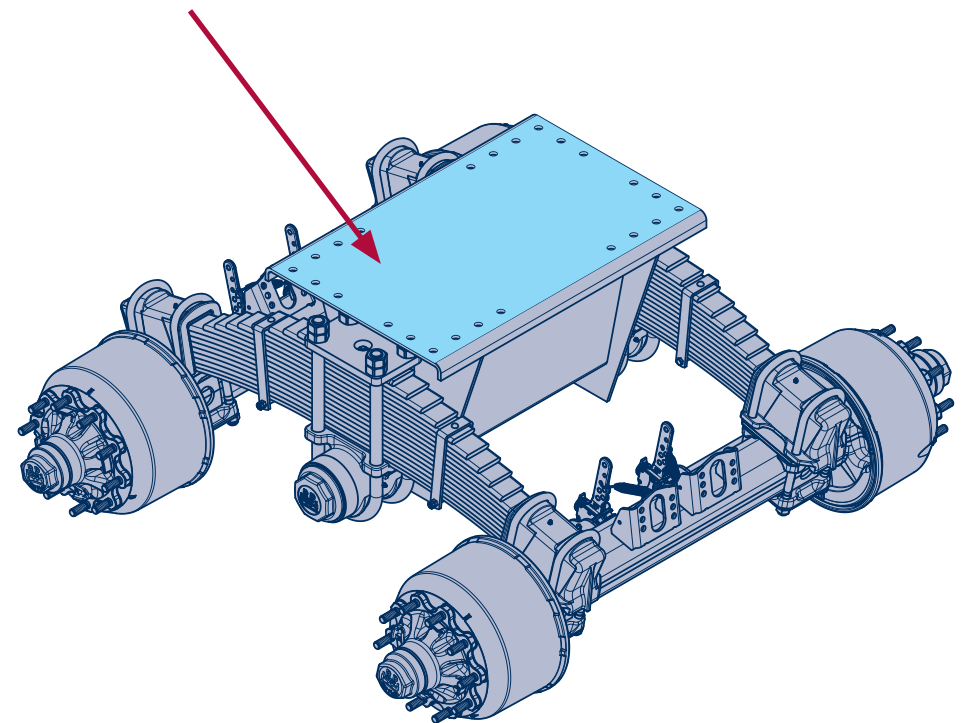
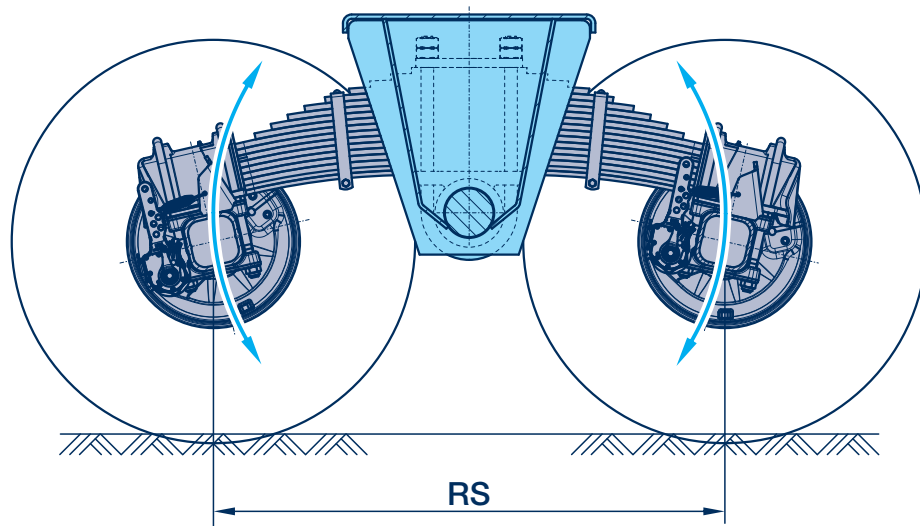

4.4.3 Alignment

1. When the vehicle is levelled horizontally:
Measure diagonal dimensions of front and rear axle comparatively (A, B).
2. If necessary, move the entire system.
3. Weld on four shear plates.

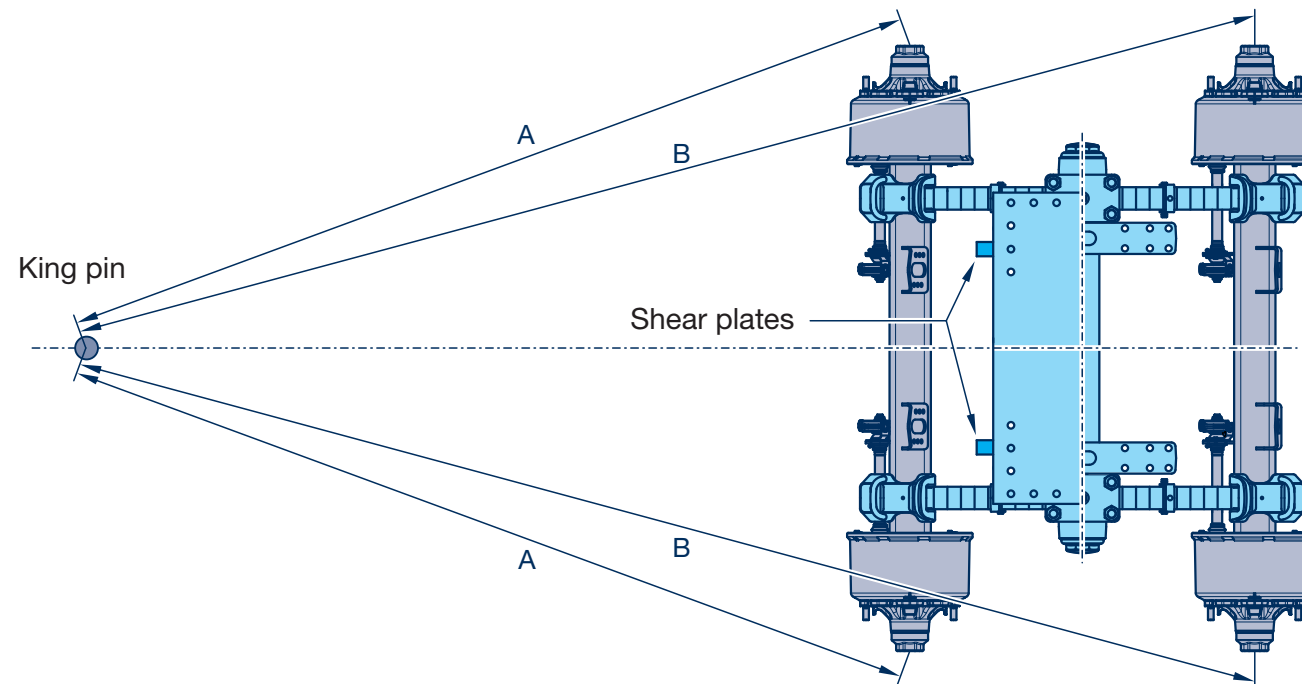

BPW is a worldwide, leading manufacturer of intelligent running gear systems for drawbar trailers and semi-trailers. From axles, through to suspensions and brakes, all the way to user-friendly telematics applications: as a mobility and system partner, we offer solutions for the transport industry, all from a single source.

In this way, we create highest transparency in loading and transport processes and enable an efficient fleet management. The tradition-conscious brand for trailer axles has now become an international group of companies with a broad portfolio of products and services for the commercial vehicles industry. BPW is the system partner for vehicle manufacturers with running gear systems, telematics, lighting systems, plastic technology and bodywork technology.

As an owner-managed company, BPW consistently pursues one goal: to always offer you exactly the solution that pays off for you in the end. To achieve this, we place our faith in uncompromising quality for high reliability and life expectancy, as well as weight and time-saving concepts for reduced operating and service costs. Moreover, we maintain a personal touch in our customer services and a dense service network for fast and direct support. In this way, you can be sure that you are always on the most cost-efficient path with your mobility partner BPW.

we think transport



**Your partner on the path
to economic viability!**

BPW Bergische Achsen Kommanditgesellschaft
PO Box 1280 · 51656 Wiehl, Germany · Tel. +49 (0) 2262 78-0
info@bpw.de · www.bpw.de

