



Maintenance instructions

BPW Trailer Axles and Suspensions



Contents

◎ 1.	Important information	Page 3
1.1	General	Page 3
1.2.	Maintenance, repair and spare parts	Page 3
1.3.	Definition On-Road / Off-Road	Page 3
1.4.	Latest version	Page 3
◎ 2.	Safety instructions	Page 4
◎ 3.	BPW Trailer axles / BPW Steering axles	Page 6
3.1	Lubrication	Page 6
3.2	Maintenance Work and Visual Inspection	
3.2.1	General	Page 23
3.2.3	Drum brakes	Page 24
3.2.3	Disc brakes, brake types TSB / TS2	Page 40
◎ 4.	BPW Air suspension, series EA (ECO Air)	Page 52
4.1	Overview, Maintenance Work and Visual Inspection	Page 52
4.2	Maintenance Work and Visual Inspection	Page 54
◎ 5.	BPW Air suspension, series EAC (ECO Air COMPACT)	Page 60
5.1	Overview, Maintenance Work and Visual Inspection	Page 60
5.2	Maintenance Work and Visual Inspection	Page 62
◎ 6.	BPW Air suspension, series SL / AL	Page 68
6.1	Overview, Lubrication and Maintenance Work, Visual Inspection	Page 68
6.2	Lubrication	Page 72
6.3	Maintenance Work and Visual Inspection	Page 72
◎ 7.	BPW Mechanical suspensions (leaf springs), series ECO Cargo VB / VB HD	Page 82
7.1	Overview, Lubrication and Maintenance Work, Visual Inspection	Page 82
7.2	Lubrication	Page 84
7.3	Maintenance Work and Visual Inspection	Page 85
◎ 8.	BPW Mechanical suspensions (leaf springs), series ECO Cargo W / BW / GW	Page 88
8.1	Overview, Lubrication and Maintenance Work, Visual Inspection	Page 88
8.2	Lubrication	Page 90
8.3	Maintenance Work and Visual Inspection	Page 91

Important information 1

1.1. General

The following maintenance instructions apply to BPW trailer axles and BPW suspensions for drawbar trailers and semi-trailers (manufactured from 1982 onwards). They are part of the Terms and Conditions for the ECO Plus Warranty (see warranty documents at www.bpw.co.za).

Carry out the latest maintenance instructions in accordance with the prescribed intervals in order to maintain the safe operation and roadworthiness of the vehicle. The latest version of the maintenance instructions can always be found at www.bpw.co.za. The latest printed version is available by post on request. The relevant operation and service regulations of the vehicle manufacturer and the manufacturers of other vehicle parts must also be adhered to.

These maintenance intervals are set out in calendar weeks and are listed to coincide with statutory testing requirements.

1.2. Maintenance, Repair and Spare Parts

Rectification of any discovered defects or replacement of worn parts should be carried out by a BPW Accredited Workshop unless the vehicle owner has the appropriate trained personnel, facilities, equipment and workshop manuals available and possesses an official certificate to perform interim inspections or special brake inspections.

We strongly recommend that only genuine BPW parts, brake linings in particular, are used when fitting spare parts. Parts authorised by BPW for trailer axles and axle units are regularly subjected to special inspections. BPW accepts product responsibility for them.

BPW is unable to determine whether all third party products can be used with BPW trailer axles and axle suspensions without any safety risk; this also applies even if an authorised testing organisation has accepted the product. The ECO Plus Warranty (see warranty documents) will cease to apply if spare parts other than genuine BPW spare parts are used.

1.3. Definition On-Road / Off -Road

The term „On-Road“ refers to roads having a sealed and metalled surface, in other words with an asphalt or concrete surface. Gravel roads are regarded as being Off -Road. A vehicle is also regarded as being in Off -Road operation even if it departs from sealed surfaces under operating conditions for only short periods. Off -Road operation is assumed in all cases in tipper and vehicles with comparable applications.

1.4. Latest Version

The latest maintenance instructions are dated 01. 10. 2021 and replace maintenance instructions ZA-BPW-W 33111701e. All previous maintenance instructions become invalid. We reserve the right to make any changes.

Current versions and additional information can be found at www.bpw.co.za.

2 Safety instructions

The following instructions should also be adhered to by the driver in addition to the statutory regulations:

In case of a new vehicle:

- After the first run under load conditions and after each wheel change:
 - Check wheel nuts for firm seating using a torque wrench. See point [1](#) on page 26 and 42.

- After the first two weeks (after the first runs under load conditions):
 - Check that the bolt connections of the spring attachments and axle steering devices are secure, depending on the application (On-Road or Off-Road). Observe the stipulated tightening torques.
 - Air suspensions: see [4](#) to [9](#) page 74 - 78
 - Leaf-spring suspensions: see [2](#) and [4](#) page 85 - 86
see [1](#) and [3](#) page 91

Prior to each run:

- Air reservoir of the brake and air suspension set at operating pressure.
- Visual inspection:
 - Tyre pressure
 - Wheel fixings
 - Check operation of lighting and braking systems
 - Drum brake: Check the brake pad/lining thickness when the brake pad/lining wear indicator is in the horizontal position.
 - Disc brake: Check the remaining brake pad / lining thickness.
The thickness of the remaining pad can be determined by the position of the caliper in relation to the brake carrier (see page 43).
 - Check that the air suspension has reached ride height and the air bags are not creased. This also applies after rapid loading or unloading.
 - Normal ride level of the air bags, check air bags are not creased. This also applies to rapid loading or unloading.

In the event of daily frost or in accordance with manufacturer's instructions:

- Drain off condensation water via the drainage valve at the bottom of the air reservoirs.
 - Check the valve system.
-

Quarterly:

- Clean line filter (in accordance with manufacturer's instructions).

Proper use of the braking system:

- In the event of premature wear of the brake pads, a tractor/trailer harmonisation (according to ISO 20918 is to be carried out.
- To maintain the efficiency of the braking system, regular use of the wheel brakes with the appropriate level of heat generation is recommended.
- Before proceeding with a C. O. F., the braking system performance where applicable, must be measured (see ISO 7634).
- The appropriate installation and operating instructions for BPW brake components (see www.bpw.co.za) should be observed.

We wish you a safe journey!

3 BPW Trailer axles / BPW Steering axles

3.1 Lubrication

Overview For detailed description see pages 8 - 21	Every 6 weeks ²⁾	Every 12 weeks	Every 26 weeks ^{1) 2)}	Latest annually ¹⁾	Latest every 2 years	Annually	Every 2 Years, thereafter yearly	Every 3 Years, thereafter yearly
① Steering pivot bearing, top and bottom	①							
② Brake camshaft bearing, outer and inner On-Road conditions Off-Road conditions			②	②				
③ Slack adjusters manual	③							
Slack adjuster ECO-Master: On-Road conditions Off-Road conditions			③	③				
④ Brake shoes with closed anchor eye				④				
⑤ ECO Plus 3, ECO Plus 2 and ECO ^{Plus} Unit: On-Road conditions Off-Road conditions							⑤	⑤
ECO Unit				⑤				
Conventional hub bearing			⑤					

For positions ① to ③ the use of a high-pressure central lubrication system which is capable of feeding special longlife grease of consistency class 2-3 is permissible. The use of liquid lubricants is not permitted!

¹⁾ After a long idle period, prior to initial operation actuate the brake lever and lubricate the brake camshaft bearing.

²⁾ With use under extreme conditions (e.g. extreme Off-Road use) more frequent lubrication with high pressure grease is necessary.

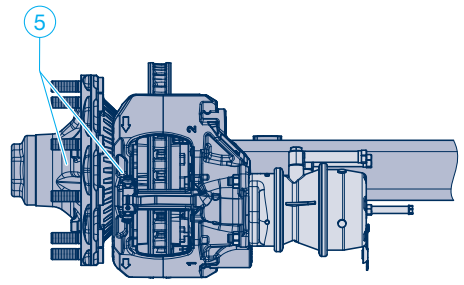
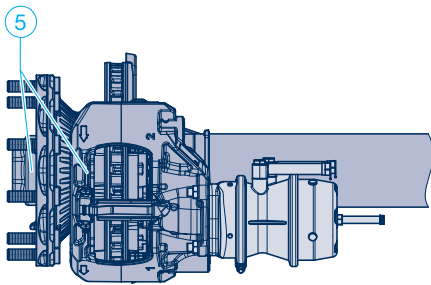
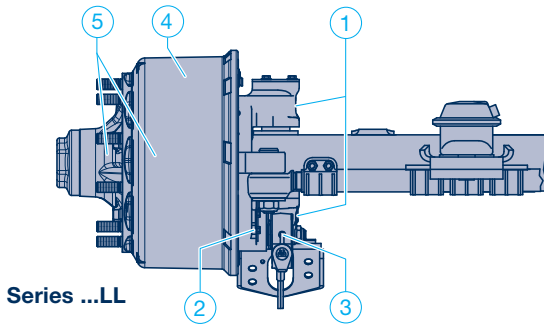
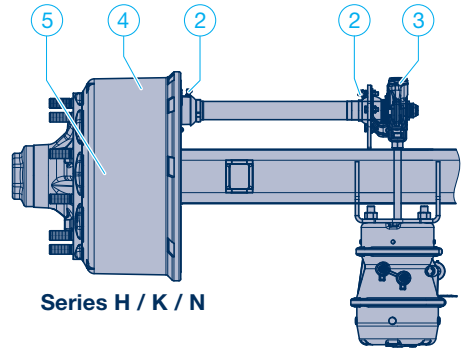
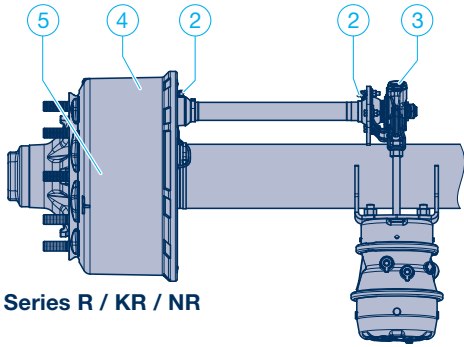

Series SR / SKR

Series SH / SKH

3 BPW Trailer axles / BPW Steering axles

3.1 Lubrication

Note: After cleaning the vehicle with high-pressure cleaners, all lubrication points must be relubricated.

① Steering pivot bearing, top and bottom – every 6 weeks –

Lift axle in order to relieve the steering pivot bearing. Grease lubrication nipple with BPW special longlife grease **ECO-Li^{Plus}** until fresh grease emerges from the bearing points.

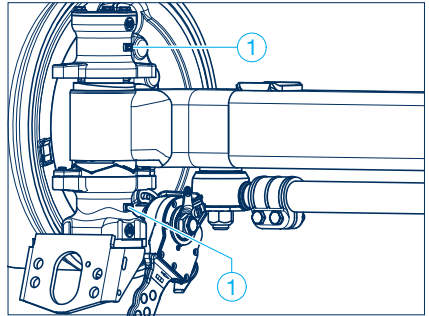

② Brake camshaft bearing, outer and inner

Low maintenance brake camshaft bearing
(from year of manufacture 1993)

- every 6 months and with each brake lining change in On-Road use –
- every 3 months in Off -Road use

Prevent the vehicle from rolling away.
Release the service brakes and the handbrake.

Lubricate the brake camshaft bearing through the grease nipple with BPW special longlife grease **ECO-LiPlus** until fresh grease emerges from the bearing points.

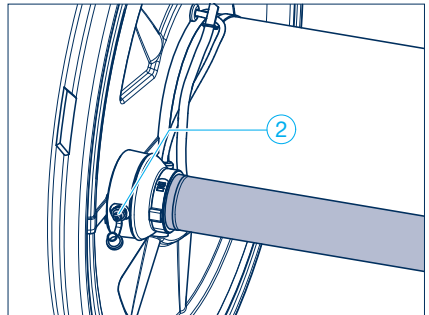

Important!
Use of other grease is not permitted!

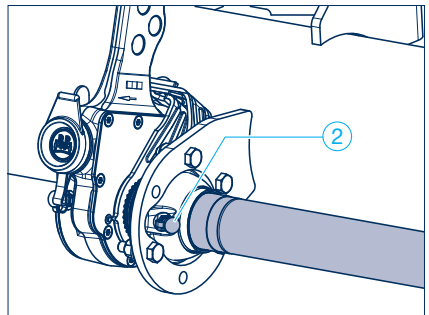

③ Slack adjusters (manual)

– quarterly –

Grease lubrication nipple with BPW special longlife grease **ECO-LiPlus** until fresh grease emerges.

Automatic slack adjuster ECO-Master

- every 6 months and with each brake lining change in On-Road use –
- every 3 months in Off -Road use

Remove rubber seal cap. Grease with BPW special longlife grease ECO-LiPlus (approx. 80 g) until sufficient new grease emerges from the adjustment bolt.

Turn back adjustment screw (keep clutch sleeve pressed down) by approx. one turn using a ring spanner. Actuate the brake lever several times by hand. The adjustment must be carried out smoothly. If necessary, repeat several times.

Once again only use BPW special longlife grease **ECO-LiPlus**.
Install seal cap.

Adjust the brake - see relevant workshop manual.

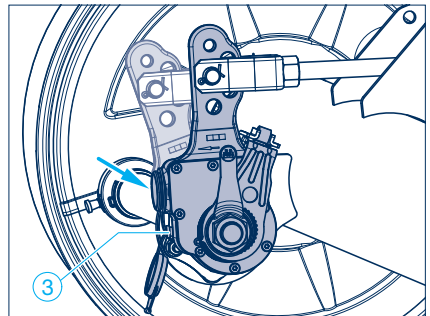
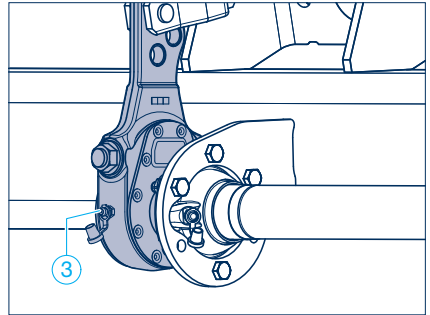

④ Brake shoes with closed anchor eye

– every 2 years and with each brake lining change –

Clean the bush and roller, check for wear and, if necessary replace. Smear BPW special longlife grease **ECO-LiPlus** onto bearing points of brake shoe.

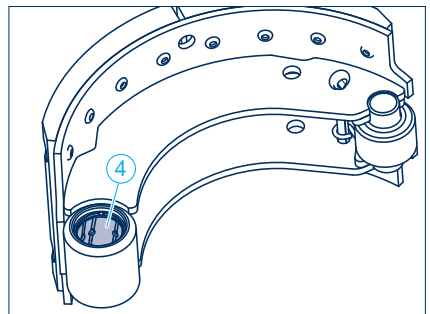

3 BPW Trailer axles / BPW Steering axles

3.1 Lubrication

5 ECO Plus 3 Unit

- for the first time after 3 years in On-Road use, and after 2 years in Off -Road use in South Africa, then at least every year depending on operating conditions –

– after 2 years in Africa then at least every year depending on operating conditions.

Prevent the vehicle from rolling away. Remove the wheel.

Unscrew the cap with a 110 mm cap spanner.

Dismantle the ECO Unit - see the corresponding workshop manuals.

 **Mark both the hub and bearing to ensure correct positioning during re-assembly. It is essential for the bearing inner rings with rollers to be re-inserted in the same hubs.**

Thoroughly clean taper roller bearings and seals (using e.g. diesel oil), dry and check for re-useability. Replace grease seal.

(Recommendation: On-road use- Evaluate the taper roller bearings, replace if necessary after 3 years. Thereafter evaluate yearly.

-Off-road use - Evaluate the taper roller bearings, replace if necessary after 2 years. Thereafter evaluate yearly.)

Work BPW special longlife grease **ECO-LiPlus** thoroughly into the cavities between the taper rollers and the cage in both taper roller bearings. (For grease quantity see illustration on page 11.) Smear any residual grease into the hub's outer bearing race.

Thoroughly clean the bearing journals of the axle stub with a microfibre cloth. The journals must be bright, dry and free from grease.

Apply Castrol White T using a fine bristled brush evenly and thinly to the bearing journals. Ensure that the bearing journal is completely coated. Castrol White T must not be diluted.

Install ECO unit whilst continuously rotating axle nut of ECO unit. It should take several turns until the clutch on the axle nut slips.



Important!
Do not use an impact driver.

Fit the retaining key in the groove between the stub axle and the nut (do not reset the axle nut).

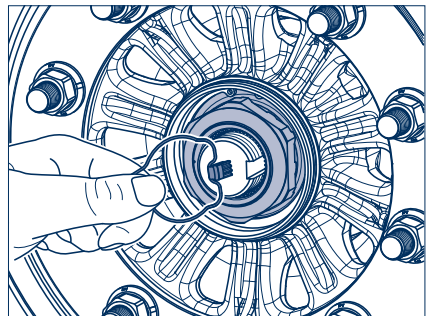
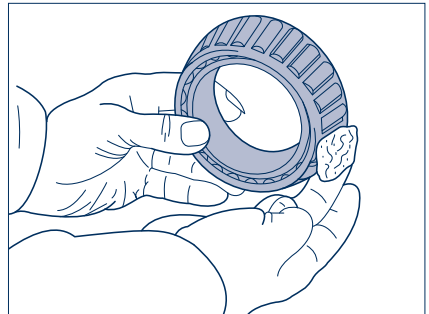
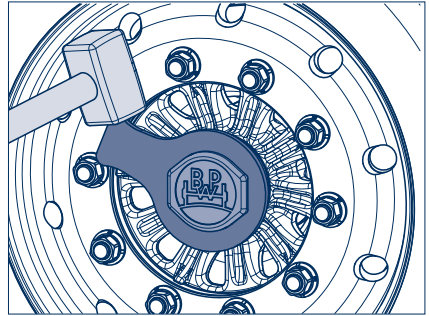

Insert the hooked retainer spring behind the formed edge of the axle nut.

Insert a new O-ring into the annular groove of the wheel hub. Apply a thin coat of BPW special long-life grease ECO-Li^{Plus} to the O-ring contact surface and thread of the hub cap.

Screw on the hub cap and tighten to **350 Nm**.

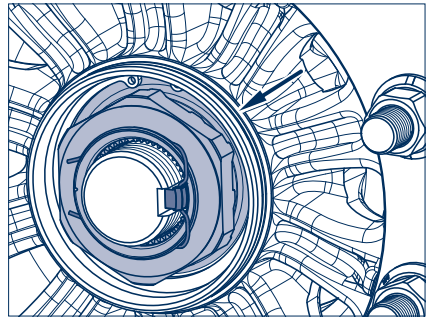

ECO Plus 3 Unit

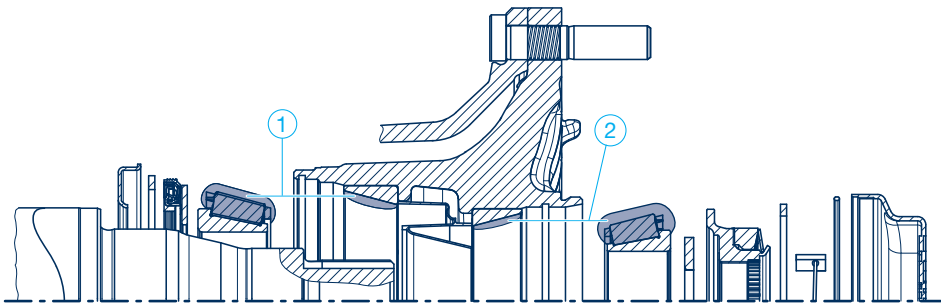

BPW special longlife grease ECO-Li^{Plus}

Grease quantity per taper roller bearing

	① Inner bearing	② Outer bearing
Manual greasing	170 g	120 g
Greasing with a grease applicator	130 g	90 g

3 BPW Trailer axles / BPW Steering axles

3.1 Lubrication

ECO Plus 2 Unit

- for the first time after 3 years in On-Road use,
or every year in Off -Road use
then at least every year depending on operating
conditions –

Prevent the vehicle from rolling away.
Remove the wheel.

Unscrew the cap with a 120 mm cap spanner.

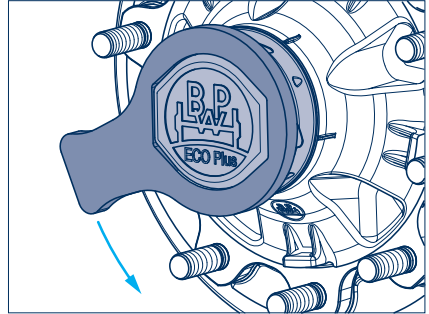

Important!
Do not use an impact driver -
bayonet lock.

Undo the cap by turning it anti-clockwise by
approx. 30° from position 1 to position 2.

When turned further the hub cap lifts clearly away
from the ECO Unit and can be removed by pulling
it away.

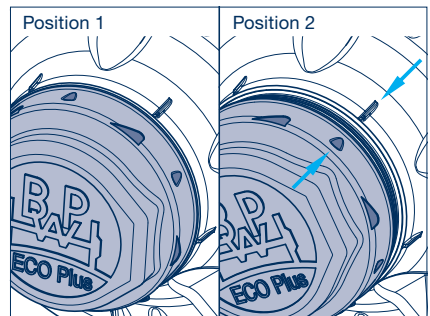

Remove the hooked spring ring and retaining key
from the axle bolt.

Unscrew the axle bolt, pulling the complete ECO
Unit off the bearing seats of the axle stub as you
do so.

Dismantle the ECO Unit - see the corresponding
workshop manuals.

 **Mark both the hub and bearing to ensure correct
positioning during re-assembly.**
It is essential for the bearing inner rings with
rollers to be re-inserted in the same hubs.

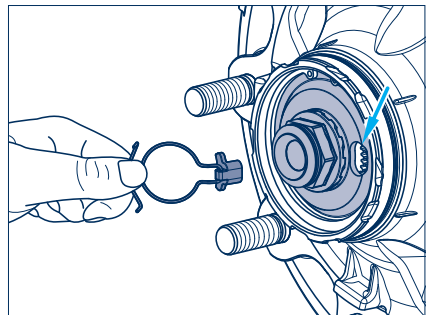

Clean the tapered roller bearings thoroughly (e.g. with diesel oil), dry them and check if they can be re-used. Fit a new shaft seal.

(Recommendation: On-road use- Evaluate the taper roller bearings, replace if necessary after 3 years. Thereafter evaluate yearly. -Off-road use - Evaluate the taper roller bearings, replace if necessary after 2 years. Thereafter evaluate yearly.)

Clean the grease cartridge and fill it on both sides up to the edge with BPW special longlife grease ECO-LiPlus. It is important to ensure that it is filled without any trapped air or cavities. Apply a ring-shaped bead of grease to the running surfaces of the bearing outer races (see arrows in illustration below).

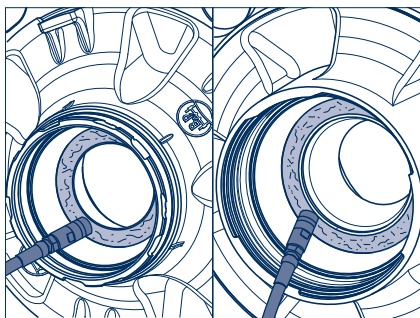

When BPW grease applicators are used, there is no need to fill the grease cartridge or to apply the bead of grease.

Mount the ECO Unit.

Thoroughly clean the bearing journals of the axle stub with a microfibre cloth. The journals must be bright, dry and free from grease. Apply Castrol White T using a fine bristled brush evenly and thinly to the bearing journals. Ensure that the bearing journal is completely coated. Castrol White T must not be diluted.

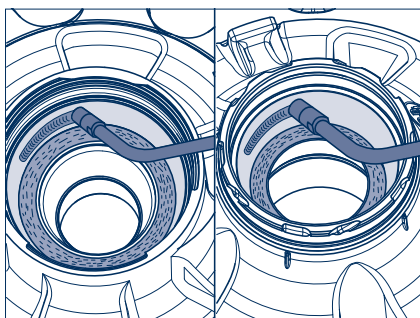

BPW special longlife grease ECO-Li ^{Plus}		
Grease quantity per taper roller bearing		
	① Inner bearing	② Outer bearing
Manual greasing	170 g	120 g
Greasing with a grease applicator	130 g	90 g

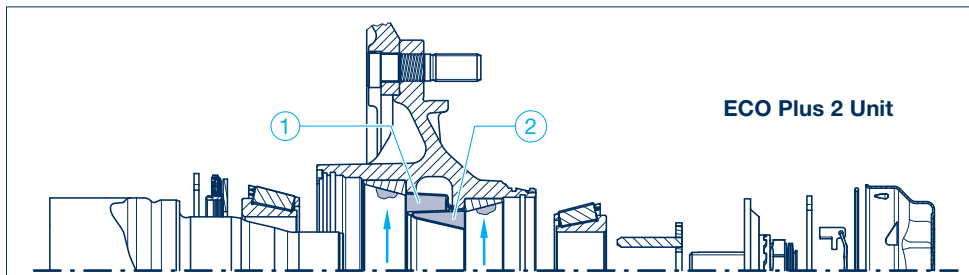

3 BPW Trailer axles / BPW Steering axles

3.1 Lubrication

Apply only a thin layer of BPW ECO-Li^{Plus} to the threaded hole in the axle stub.

 **Important!**
Do not apply too much grease!

It is necessary to make sure that the axle bolt can be completely screwed into the axle stub.

Mount the ECO Unit. Guide the toothed lock washer into the hole in the axle stub. The position of the pin can be seen by the punched-in BPW logo in the recess of the axle bolt.

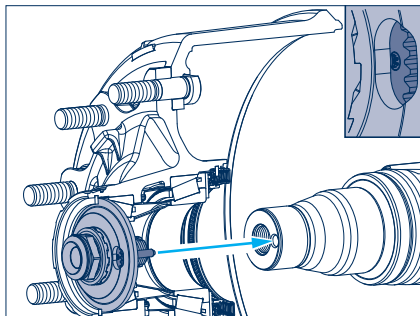

Fasten axle bolt (SW 46) whilst rotating the ECO hub unit. It should take several turns until the clutch on the axle bolt slips. (Do not turn back the axle bolt).



Important!
Do not use an impact driver.

Insert the retaining key into the recess in the axle bolt and the gearing of the toothed lock washer. (Do not turn back the axle bolt.)

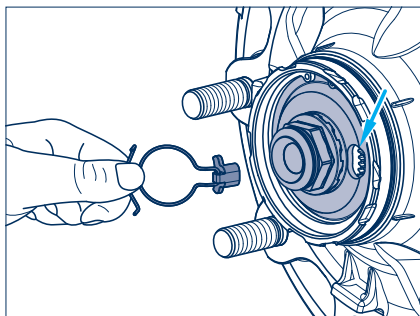

Insert the hooked spring ring into the groove of the hexagon profile of the axle bolt.

 **Make sure that the hooked spring ring assembly is correctly seated in the annular groove of the axle bolt.**

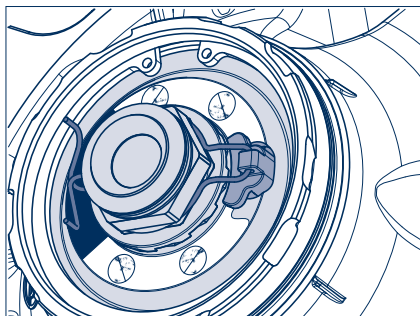

Insert a new O-ring into the groove in the wheel hub.

Apply a thin layer of BPW ECO-Li^{Plus} special longlife grease to the cap in the area of the O-ring contact surface and the bayonet fitting.

Screw on the cap with a 120 mm cap spanner.



Important!
Do not use an impact driver -
bayonet lock.

Push on the cap, see position 1.

Press on the cap and turn it by approx. 30° in a clockwise direction to lock it in place. A tight seat is provided when position 2 is reached.

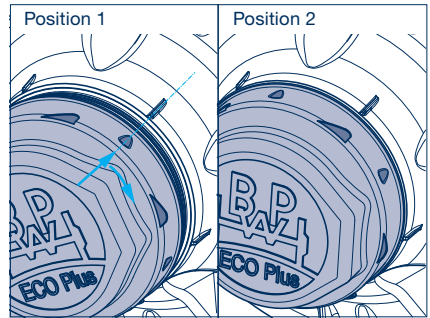

3 BPW Trailer axles / BPW Steering axles

3.1 Lubrication

ECO^{Plus} Unit



- for the first time after 3 years in On-Road use, and after 2 years in Off -Road use in South Africa, then at least every year depending on operating conditions –

– after 2 years in Africa then at least every year depending on operating conditions.

Prevent the vehicle from rolling away. Remove the wheel.

Unscrew the cap with a 110 mm cap spanner.

Dismantle the ECO Unit - see the corresponding workshop manuals.

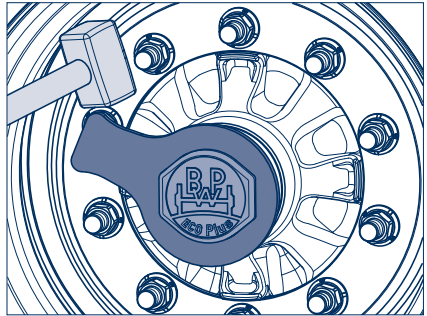

Mark both the hub and bearing to ensure correct positioning during re-assembly. It is essential for the bearing inner rings with rollers to be re-inserted in the same hubs.

Thoroughly clean taper roller bearings and seals (using e.g. diesel oil), dry and check for re-useability. Replace grease seal.

(Recommendation: On-road use- Evaluate the taper roller bearings, replace if necessary after 3 years. Thereafter evaluate yearly.

-Off-road use - Evaluate the taper roller bearings, replace if necessary after 2 years. Thereafter evaluate yearly.)

Work BPW special longlife grease **ECO-LiPlus** thoroughly into the cavities between the taper rollers and the cage in both taper roller bearings. (For grease quantity see illustration on page 11.) Smear any residual grease into the hub's outer bearing race.

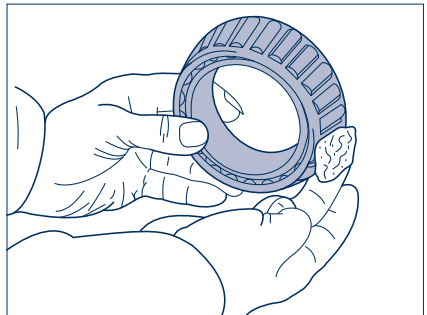

Thoroughly clean the bearing journals of the axle stub with a microfibre cloth. The journals must be bright, dry and free from grease.

Apply Castrol White T using a fine bristled brush evenly and thinly to the bearing journals. Ensure that the bearing journal is completely coated. Castrol White T must not be diluted.

Install ECO unit whilst continuously rotating axle nut of ECO unit. It should take several turns until the clutch on the axle nut slips.

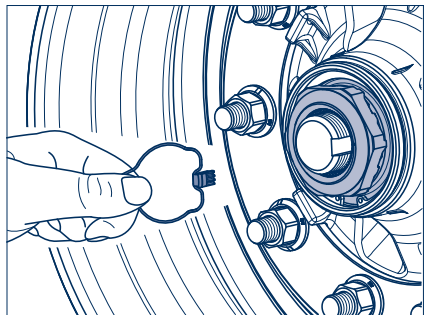

Important!

Do not use an impact driver.

Fit the retaining key in the groove between the stub axle and the nut (do not reset the axle nut).

For production date April 2000 onwards, insert the hooked spring ring behind the edge of the axle nut or, up to March 2000, into the thread on the axle stub. Screw on the cap and tighten to 800 Nm.

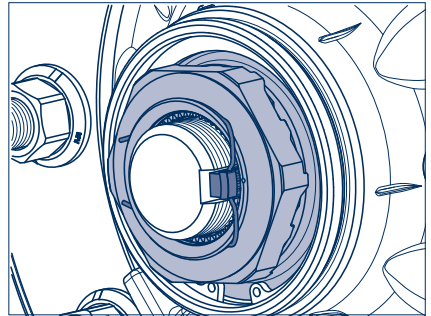

Trailer axles

ECO^{Plus} Unit

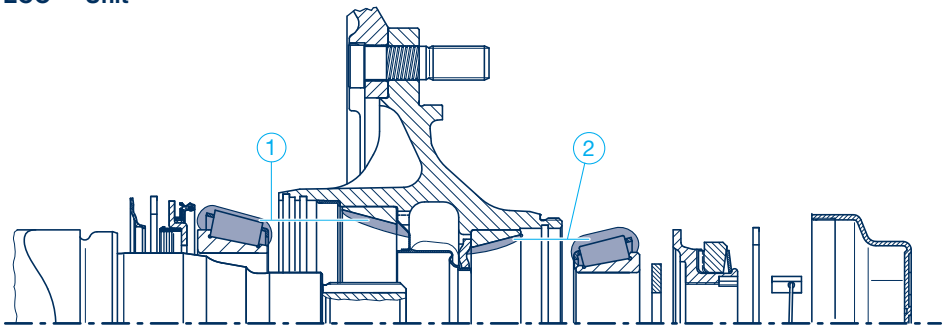

BPW special longlife grease ECO-Li^{Plus}

Grease quantity per taper roller bearing

	① Inner bearing	② Outer bearing
Manual greasing	170 g	120 g
Greasing with a grease applicator	130 g	90 g

3 BPW Trailer axles / BPW Steering axles

3.1 Lubrication

ECO Unit - annually -

Prevent the vehicle from rolling away.
Remove the wheel.

Unscrew the cap with a 110 mm cap spanner.

Dismantle the ECO Unit - see the corresponding workshop manuals.

Mark both the hub and bearing to ensure correct positioning during re-assembly. It is essential for the bearing inner rings with rollers to be re-inserted in the same hubs.

Thoroughly clean taper roller bearings and seals (using e.g. diesel oil), dry and check for re-useability. Replace grease seal.

Work BPW special longlife grease **ECO-Li^{Plus}** thoroughly into the cavities between the taper rollers and the cage in both taper roller bearings.

Comply with the total grease quantity in tables **A** and **B**.

Smear any residual grease into the hub's outer bearing race. Smear the lip of the new grease seal all round with BPW special longlife grease **ECO-Li^{Plus}**.

Thoroughly clean the bearing journals of the axle stub with a microfiber cloth. The journals must be bright, dry and free from grease.

Apply **Castrol White T** using a fine bristled brush evenly and thinly to the bearing journals. Ensure that the bearing journal is completely coated. Castrol White T must not be diluted.

Fit the ECO Unit.

Fasten axle nut using a torque wrench whilst rotating the ECO hub unit. It should take several turns until the tightening torque has reached 150 Nm.

If the groove of the axle nut is the same size as a bore hole of the axle stub, the safety bolt must be removed directly. If this action is not performed, the axle nut must be turned back until the next opportunity to secure it (less than 15°).

Fit pin with a snap hook.
Tighten the cap to 800 Nm.

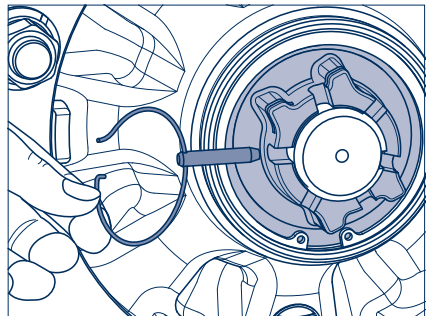
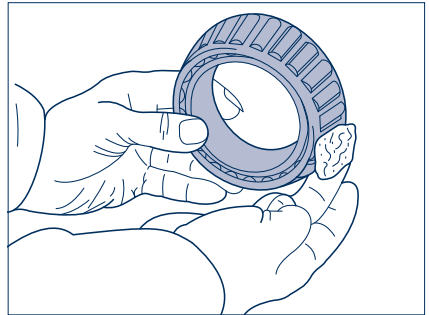

ECO Unit

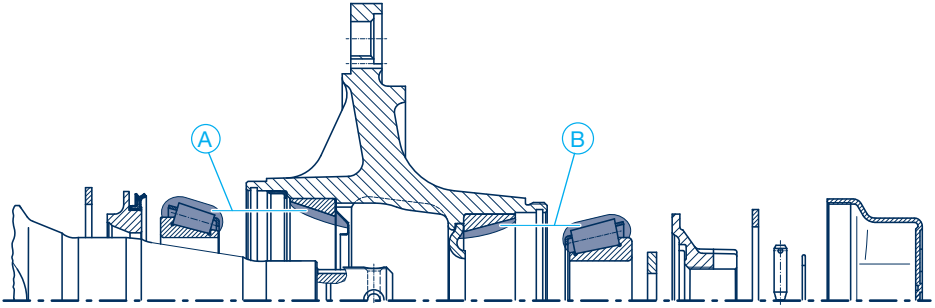

BPW special longlife grease ECO-Li^{Plus}

Grease quantity per taper roller bearing

Axle load	Ⓐ Inner bearing	Ⓑ Outer bearing
6000 - 9000 kg	120 g	120 g
10000 - 12000 kg	170 g	120 g
13000 - 14000 kg	230 g	150 g

3 BPW Trailer axles / BPW Steering axles

3.1 Lubrication

Change wheel hub bearing grease (Conventional)

– annually

For demounting and re-fitting of wheel hubs, see workshop manuals.

Mark both the hub and bearing to ensure correct positioning during re-assembly.

It is essential for the bearing inner rings with rollers to be re-inserted in the same hubs.

Clean wheel hubs thoroughly inside and outside. Remove old grease completely.

Thoroughly clean taper bearings (using e. g. diesel oil) dry and check for re-useability. Replace seals.

Work BPW special longlife grease ECO-Li^{Plus} into the cavities between the taper rollers and cage.

Comply with total grease quantity (table **A**), smear any residual grease into the hub's outer bearing race.

Fit wheel hubs and adjust bearing play (see point **7** page 38).

Fill hub caps with BPW special longlife grease ECO-Li^{Plus} (table **B**) and screw on.

For tightening torques see **5** page 31.

 For 16 - 18 t axles with BPW oval shape hub cap, a new O-ring must be fitted on reassembly.

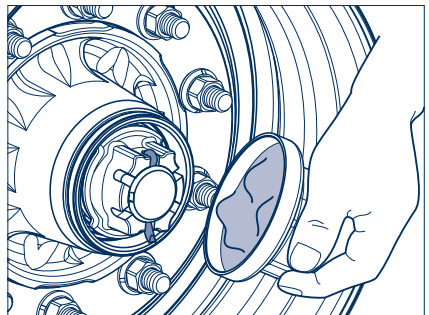
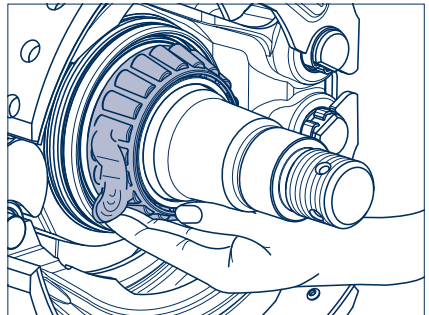
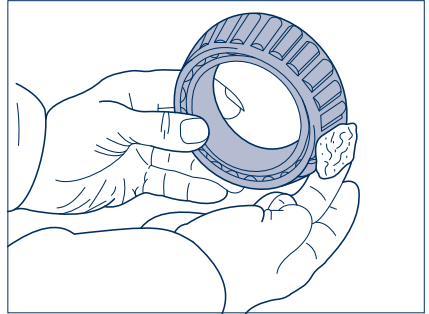

Conventional wheel hub bearing

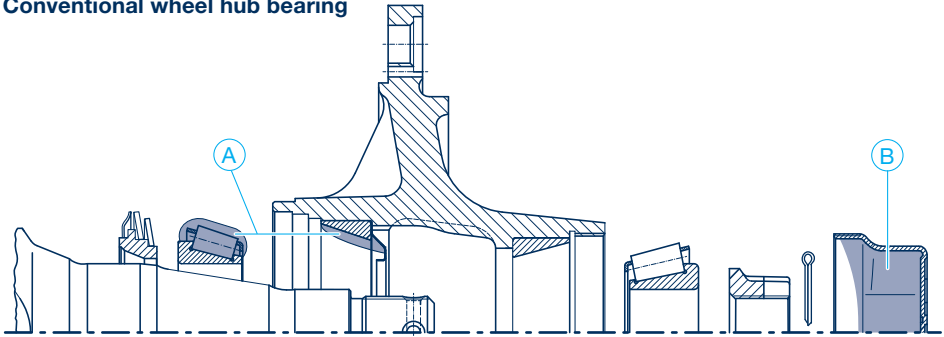

BPW special longlife grease ECO-Li^{Plus}
Grease quantity per taper roller bearing

Axle load (Series H, K, N, M)	Ⓐ Inner bearing	Ⓑ Outer bearing (cap filling)
4000 - 5500 kg	80 g	130 g
6000 - 9000 kg	170 g	290 g
10000 - 12000 kg	180 g	320 g
13000 - 14000 kg	240 g	500 g
16000 - 18000 kg	400 g	800 g
20000 kg	440 g	900 g
Axke load (Series E and NE)		
3000 kg	70 g	100 g
3500 - 3800 kg	80 g	120 g
4500 kg	90 g	180 g



BPW Trailer axles / BPW Steering axles **3**

Maintenance Work and Visual Inspection **3.2**

General **3.2.1**

In order to distribute the braking effort evenly to all the brakes in the unit, **adjustment must always be carried out according to the vehicle manufacturer's specifications, or after 5,000 km.** Tractor units with EBS cannot have their brakes adjusted in the normal manner. As a result, the trailer or semi-trailer merely has to be checked for compliance with the EC tolerance bands. Always check the tractor vehicle if the trailer is in the EC band despite premature brake pad wear. The EBS parameters in the tractor unit must be modified in order to improve compatibility, see ECE R 13 in this connection. Failure to do so will invalidate the warranty (see warranty documents).

Other possible solutions to premature brake pad wear:

- Prescribed maintenance work must be performed at regular intervals.
- Use the retarder or engine brake to adjust the vehicle's speed.
- Think ahead when driving.
- Drop down to a lower gear in good time.
- BPW Disc Protector (cover plates for brake discs).

Even at high temperatures, disc brakes display stable braking properties and a high level of safety. Excessive temperatures do not make themselves apparent through brake fading and should be avoided. This effect leads to increased wear when used under these conditions.

3 BPW Trailer axles / BPW Steering axles

3.2 Maintenance Work and Visual Inspection

3.2.2 Drum brakes

Overview		Initially	Every 1 to 3 weeks	Every 12 weeks	Every 26 weeks ²⁾	At every brake lining replacement, latest annually ²⁾
For detailed description, see pages 26 - 39						
Disc brakes, see pages 40 - 50						
Air suspension, see pages 52 - 80						
Suspension, see pages 82 - 91						
Maintenance work - Drum brakes						
1	Check wheel nuts for tightness.	1 ¹⁾				
2	With manual slack adjusters, check brake play, adjust if necessary to 10 - 12% of the connected brake lever length and activate by hand or with 0.5 - 0.8 bar. (Not applicable in the case of automatic slack adjusters.)		2			
-	Check the tyres for uneven wear, adjust the inflation pressure if necessary, according to the manufacturer's specifications.			-		
3	Check brake lining thickness is at least 5 mm. (Brake SN 300 min. 7 mm and N 3006 min. 2.5 mm residual lining thickness.)			3		
4	Check brake drum for cracks and check the internal diameter.			4		
5	Check caps for firm seating (not necessary with ECO Plus 3, ECO Plus 2 and ECO ^{Plus} axles).				5	
6	Check operation of automatic slack adjusters.			6 ²⁾		
o	Visual inspection of all component parts and welding seams for damage and wear.			o ²⁾		
7	Check wheel hub bearing play, adjust if necessary. - ECO Plus 3, ECO Plus 2 and ECO ^{Plus} Unit - ECO Unit, conventional bearing				7	7

¹⁾ After the first run under load conditions, likewise after each wheel change.

²⁾ Under extreme conditions, increase frequency (e.g. construction sites and poor roads).

Note: Components that have damage due to improper mounting are to be exchanged

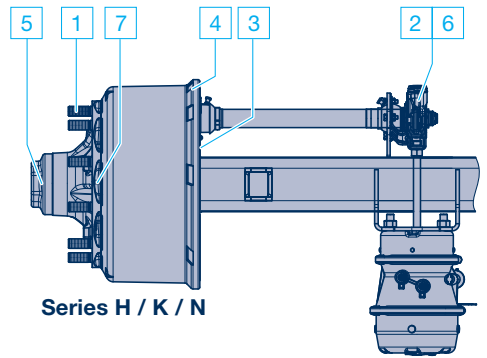
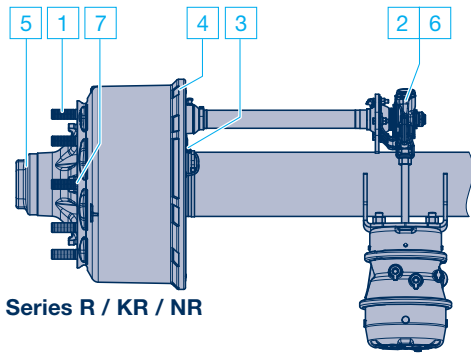

Trailer axles

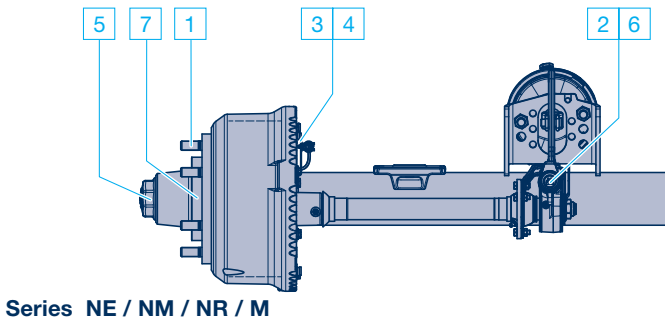
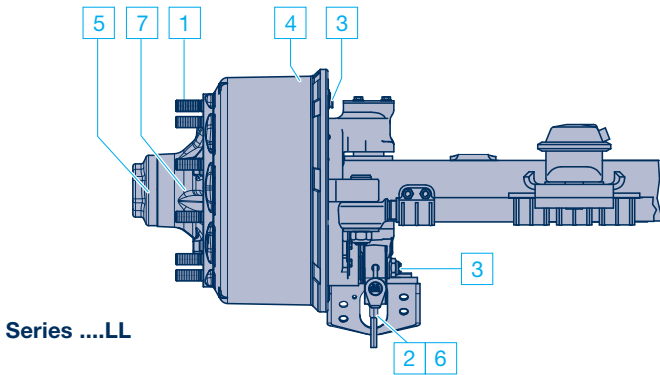

3 BPW Trailer axles / BPW Steering axles

3.2 Maintenance Work and Visual Inspection

3.2.2 Drum brakes

1 Check wheel nuts for tightness

- the tightening torque of the wheel nuts must be checked after the first high load journey as well as after each wheel change and, if appropriate, retightened to the prescribed value –

Tighten wheel nuts diagonally using a torque wrench to the tightening torque shown in the table.

In the case of Trilex-wheels tighten the nuts consecutively several times around.

Wheel contact surfaces should not have additional coats of paint (risk of the wheels becoming detached!)

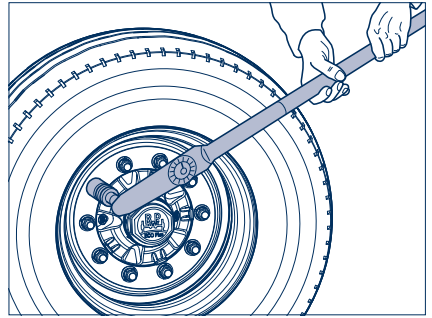

Tightening torque for wheel nuts



It is imperative that the prescribed tightening torques are adhered to in order to ensure the wheels are securely fastened! The wheel studs must be clean and free of damage and the nuts must be easily tightened and loosened. If needed, lightly oil the contact surface between the wheel nut and the pressure disc. Do not oil or grease the thread of the wheel studs and wheel nuts.



The use of aggressive and acidic rim cleaners is not permitted. Such agents can seriously impair the anti-corrosion coating of wheel bolts and wheel nuts.

Stud alignment	Tightening torque	
M 14 x 1.5	125 Nm (120 - 130 Nm)	
M 18 x 1.5	290 Nm (275 - 305 Nm)	
M 20 x 1.5	380 Nm (360 - 400 Nm)	
M 22 x 1.5	510 Nm (485 - 535 Nm)	
M 22 x 2	460 Nm (435 - 485 Nm)	

Spigot alignment	Tightening torque	Wheel nut with collar
M 18 x 1.5	350 Nm (330 - 370 Nm)	
M 20 x 1.5	480 Nm (455 - 505 Nm)	
M 22 x 1.5	630 Nm (600 - 660 Nm)	
M 22 x 1.5 alloy wheels	630 Nm (600 - 660 Nm)	
M 24 x 1.5	860 Nm (820 - 900 Nm)	

Trilex-wheels	Tightening torque	
M 18 x 2	285 Nm (270 - 300 Nm)	
M 20 x 2	335 Nm (320 - 350 Nm)	

Japan connection	Tightening torque	
M 20 x 1.5	570 Nm (540 - 600 Nm)	
M 30 x 1.5	570 Nm (540 - 600 Nm)	

The torque values shown below can be achieved using a normal wheel nut spanner (vehicle tool kit) and a length of tubing.

However always check with a torque wrench as soon as possible afterwards.

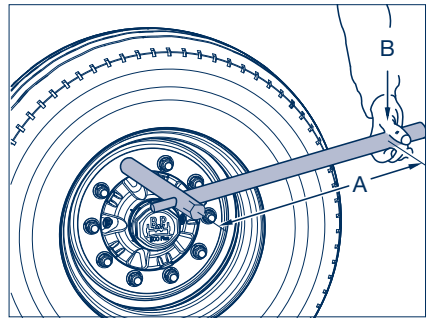

To achieve tightening torques with on-board tools

Tightening torque	Tubing length „A“	Tubing length „B“
270 - 310 Nm	300 mm	90 - 105 kg
	350 mm	78 - 89 kg
	400 mm	68 - 78 kg
320 - 350 Nm	350 mm	91 - 99 kg
	400 mm	80 - 88 kg
	450 mm	71 - 78 kg
	500 mm	64 - 70 kg
360 - 400 Nm	400 mm	90 - 99 kg
	450 mm	80 - 89 kg
	500 mm	72 - 80 kg
	600 mm	60 - 67 kg
440 - 480 Nm	500 mm	88 - 96 kg
	600 mm	73 - 80 kg
	700 mm	63 - 69 kg
480 - 540 Nm	600 mm	80 - 90 kg
	700 mm	67 - 77 kg
	800 mm	60 - 67 kg
600 - 660 Nm	700 mm	85 - 95 kg
	800 mm	75 - 83 kg
	900 mm	67 - 73 kg
	1000 mm	60 - 66 kg
820 - 900 Nm	1000 mm	82 - 90 kg

3 BPW Trailer axles / BPW Steering axles

3.2 Maintenance Work and Visual Inspection

3.2.2 Drum brakes

2 Check and adjust wheel brake play with manual slack adjusters

- frequent checks are necessary -
- depending upon application every 1 to 3 weeks -

Actuate slack adjusters by hand, pulling against the return spring. If there is more than 35 mm of play, the slack adjuster must be reset. This can be done by adjusting the nut on the slack adjuster as shown.

Adjust the play "a" to 10 -12% of the connected brake lever length "B", e.g. lever length 150 mm = 15 - 18 mm of play.

Automatic slack adjusters make this adjustment automatically whenever the camshaft is rotated by more than 17.5°.

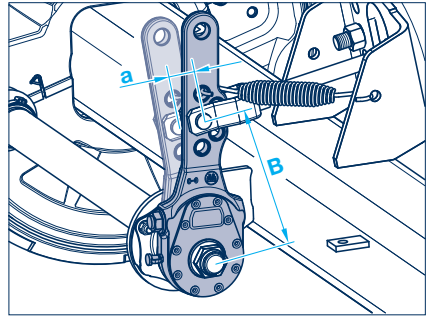

- Check the tyres for uneven wear, adjust the inflation pressure if necessary according to the manufacturer's specifications.
- quarterly -

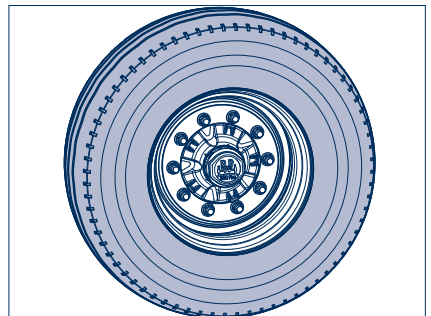

3 Check brake lining thickness
 – quarterly –

Open inspection hole by folding back the rubber flap (not required with ECO Drum brakes).

The brake lining should be replaced at a residual lining thickness of 5 mm, SN 300 min. 7 mm, N 3006 min. 2.5 mm (check with slide gauge) or on reaching the bottom of the indicator machined into the edge of the lining.

Re-insert the rubber flap.

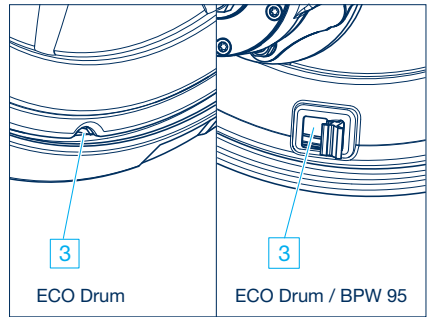

If brake lining wear indicators are fitted to the slack adjusters, the minimum thickness of the brake linings is indicated by the horizontal position of the lever (when the brake is released).

The Brake Monitor displays the “Service” signal when the wear sensor for drum brakes is installed. There is no warning function.

In certain cases the slack adjusters may not be fitted in the normal (i.e. vertical) position. In such instances, the position of the wear indicator will also be different. Linings should be changed when the wear indicator is approximately at right angles to the brake lever.

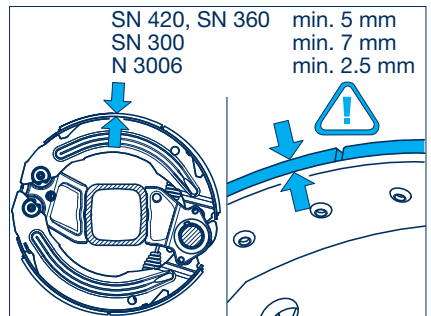
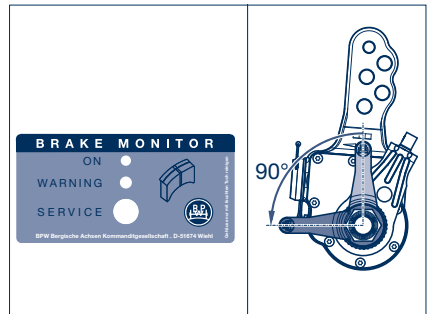

3 BPW Trailer axles / BPW Steering axles

3.2 Maintenance Work and Visual Inspection

3.2.2 Drum brakes

- 4 Check the brake drum for cracks and the internal diameter – quarterly –

Check the condition of the brake drum and that there is adequate remaining thickness. If the wear is approaching the wear edge, measure the brake drum and renew it if the maximum permitted amount of wear has been reached.

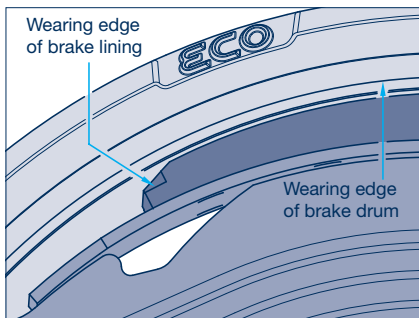

Max. amounts of wear, measured at the position with the greatest wear:

Brake	Brake shoe width (mm)	∅ Max. amount of wear (mm)	∅ Skimming size (mm)
SN 420	120 / 160	424	423
SN 420	180 / 200 / 220	425.5	424
SN 360	160 / 200	364	363
SN 300	100 / 150 / 200	304	303
FL 300	80	303	302

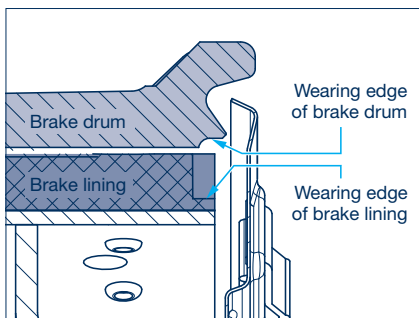
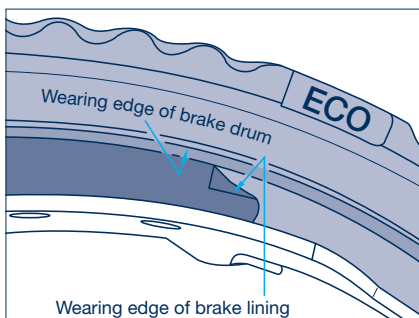

5 Check caps for firm seating

– every 6 months –
 (not necessary with ECO Plus 3, ECO Plus 2 and ECO^{Plus} axles)

Check caps for tightness using a torque wrench or power tool. Tightening torque:

Hub caps with BPW oval shape:

ECO Plus 3 Unit		SW 110	350 Nm
ECO ^{Plus} Unit	8 - 12 t	SW 110	800 Nm
ECO Unit	6.5 - 12 t	SW 110	800 Nm
	13 - 14 t	SW 120	800 Nm
Steel hub cap for conventional bearing hub (oval)			
	6.5 - 9 t	SW 95	500 Nm
	10 - 12 t	SW 110	500 Nm
	13 - 14 t	SW 120	800 Nm
	16 - 18 t	SW 140	350 Nm
Alloy cap	6 - 12 t	SW 110	350 Nm

Hub cap with octagonal shape:

13 - 20 t	SW 120	700 Nm
-----------	--------	--------

In an emergency the caps can be tightened using a normal cap spanner (vehicle tool kit) by striking the latter with a hammer, or also with the aid of a piece of tubing placed over the wheel nut.

Caps with integrated hubodometers must be fitted and dismantled using only torque controlled (DO NOT USE AIR IMPACT WRENCHES!) air guns or manually with a torque wrench.

Tighten to the correct tightening torque as soon as possible.

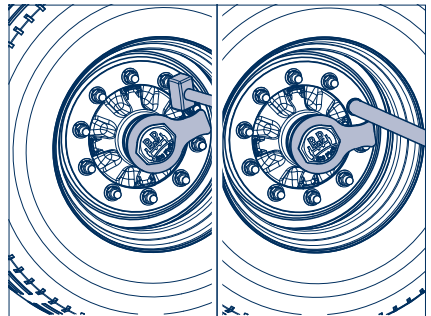
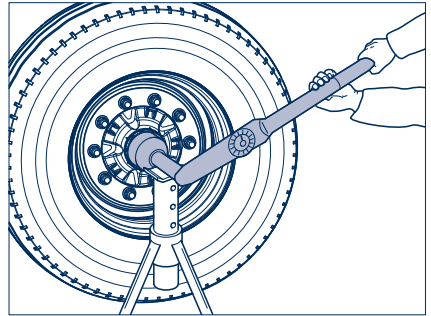

👉 Caps on ECO Plus 2 axles are provided with a bayonet fitting. Check for firm seating.

Position 1: Hub cap seated loosely on the Unit.

Position 2: Hub cap seated firmly on the Unit.

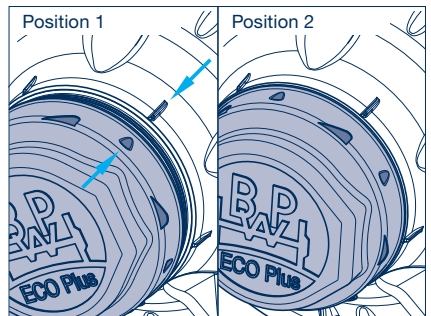

3 BPW Trailer axles / BPW Steering axles

3.2 Maintenance Work and Visual Inspection

3.2.2 Drum brakes

- 6 Check operation of the automatic slack adjusters
– every 3 months –

Prevent the vehicle from rolling away.
Release the service brakes and the handbrake.

Free play check:

Operate the slack adjuster by hand or with 0.8 bar. In this case, the free play "a" corresponds to 10 - 15 % of the connected brake lever length "B", e.g. brake lever length 150 mm = free play 15 - 22 mm.

Check the adjustment if the free play is not within tolerance:

Remove rubber seal cap. Keep clutch sleeve pressed down and turn back adjustment bolt (arrow) by approx. 3/4 of a turn in a counterclockwise direction using a ring spanner. A play of at least 50 mm with a lever length of 150 mm must be available.

Actuate the brake lever several times by hand. When this is done automatic adjustment must take place smoothly. Engagement of the clutch coupling is audible and on the return stroke the adjustment bolt turns slightly in a clockwise direction. Grease with **ECO-Li^{Plus}**, see also ③ on page 9.

Fit seal cap.

Adjust the brake, see relevant workshop manual.

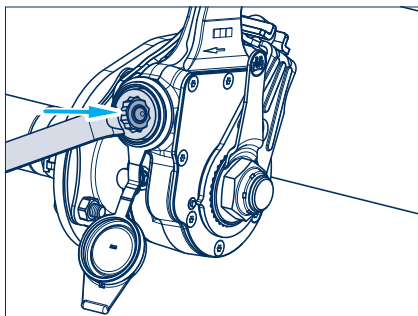
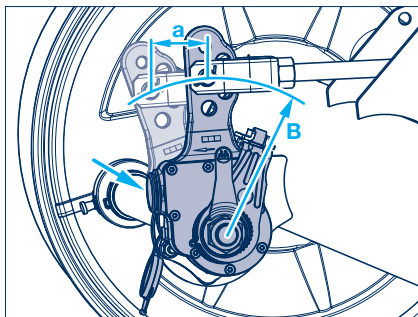

- Visual inspection
– every 3 months –

Check all components and welding seams for damage and wear.

7 Check wheel hub bearing play
- every 6 months -

Prevent the vehicle from rolling away.

In order to check the wheel hub bearing play, lift the axle until the wheels are off the ground. Release the brake. Apply a lever between the tyre and the ground and check the play.

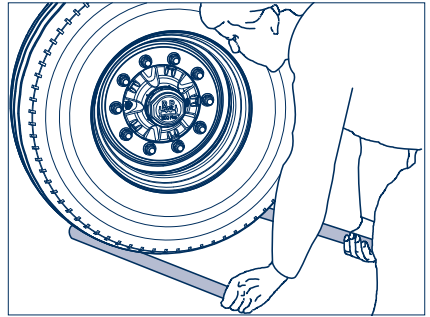

If bearing play is detected - **ECO Plus 3 Unit**:

Adjust the bearing play

1. Unscrew the cap.
2. Remove the hooked spring ring with a wedge from the axle nut.
3. Fasten axle nut using a hexagon socket spanner whilst rotating the ECO hub unit. It is necessary to turn the ECO Unit numerous times before the gearing slips over the axle nut.



Attention!
Do not use an impact driver.

4. Fit the retaining key in the groove between the stub axle and the nut (do not reset the axle nut).
5. Insert the hooked retainer spring behind the formed edge of the axle nut.
6. Insert a new O-ring into the annular groove of the wheel hub. Apply a thin coat of BPW special long-life grease ECO-Li^{plus} to the O-ring contact surface and thread of the hub cap.
7. Screw on the hub cap and tighten to 350 Nm.

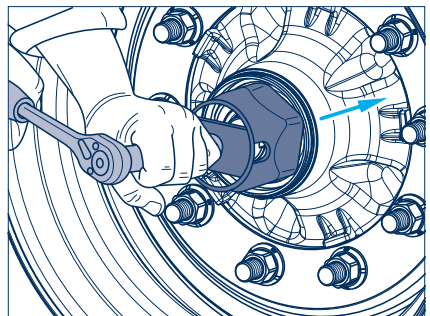
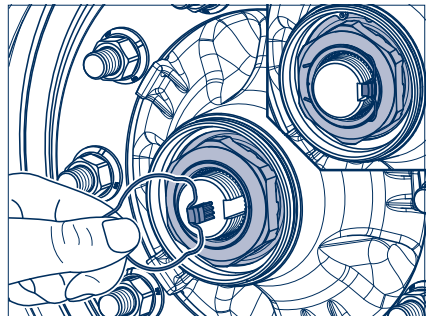

3 BPW Trailer axles / BPW Steering axles

3.2 Maintenance Work and Visual Inspection

3.2.2 Drum brakes

If bearing play is detected - **ECO Plus 2 Unit**:

Adjust the bearing play

1. Unscrew the cap with a 120 mm hub cap spanner. Undo the cap by turning it anti-clockwise by approx. 30° from position 1 to position 2.

When turned further the hub cap lifts clearly away from the ECO Unit and can be removed by pulling it away.



Attention!
Do not use an impact driver -
bayonet lock.

2. Remove the hooked spring ring and retaining key from the axle bolt.

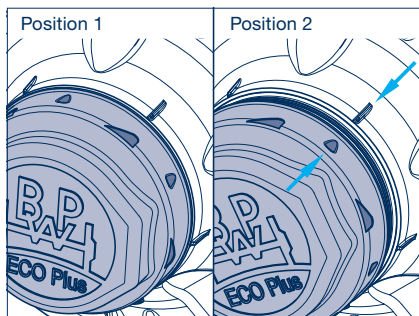
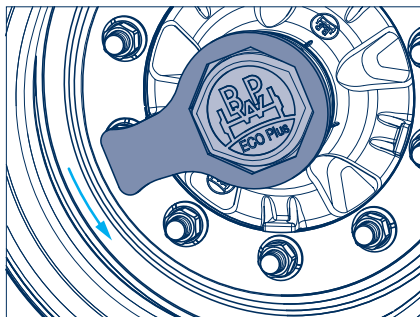

3. Tighten the axle bolt (SW 46) using a hexagon socket spanner whilst simultaneously rotating the ECO hub unit.

It is necessary to turn the ECO Unit numerous times before the gearing slips over the axle bolt.



Attention!
Do not use an impact driver.

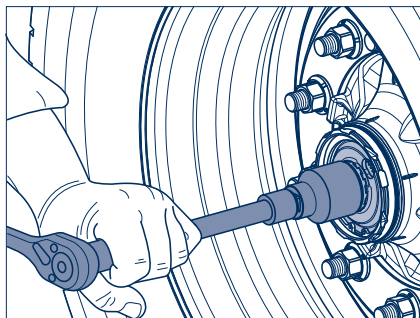

4. Insert the retaining key into the recess in the axle bolt and the gearing of the toothed lock washer (arrow). (Do not turn back the axle bolt.)
5. Insert the hooked spring ring into the groove of the hexagon profile of the axle bolt. Make sure that the hooked spring ring assembly is correctly seated in the annular groove of the axle bolt.
6. Insert a new O-ring into the groove in the wheel hub.

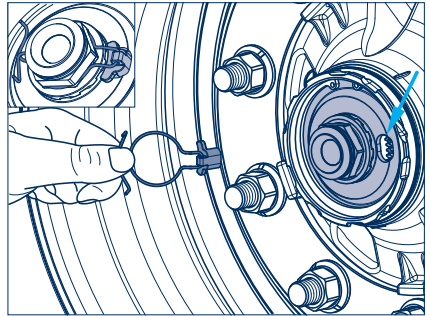

7. Apply a thin layer of BPW ECO-Li^{Plus} special longlife grease to the hubcap in the area of the O-ring contact surface and the bayonet fitting.
8. Screw on the cap with a 120 mm cap spanner.



Attention!
Do not use an impact driver - bayonet lock.

Push on the hubcap, see position 1.
Press on the hubcap and turn it by approx. 30° in a clockwise direction to lock it in place.
A tight seat is provided when position 2 is reached.

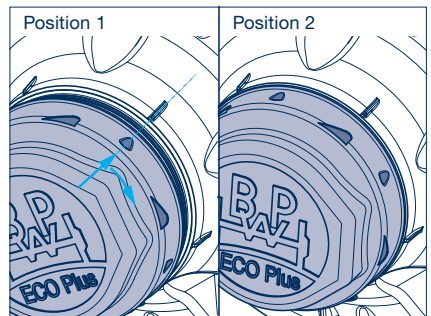

3 BPW Trailer axles / BPW Steering axles

3.2 Maintenance Work and Visual Inspection

3.2.2 Drum brakes

If bearing play is detected - **ECO^{Plus} Unit**:

Adjust the bearing play

1. Unscrew the cap.
2. Remove the hooked spring ring with a wedge from the axle nut.
3. Fasten axle nut using a hexagon socket spanner whilst rotating the ECO Unit.
It is necessary to turn the ECO Unit numerous times before the gearing slips over the axle nut.



Attention!
Do not use an impact driver.

4. Fit the retaining key in the groove between the axle stub and the nut (do not reset the axle nut).
5. For production date April 2000 onwards, insert the hooked spring ring behind the edge of the axle nut or, up to March 2000, into the thread on the axle stub.
6. Tighten the cap to 800 Nm.

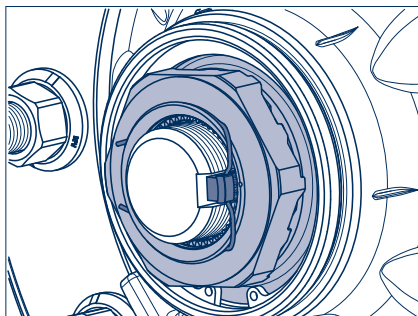
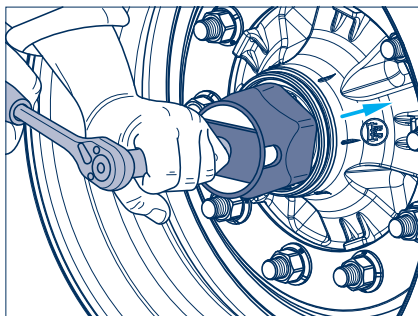
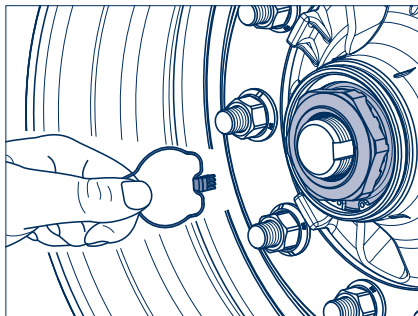

If bearing play is detected - **ECO Unit:**

Adjust the bearing play

1. Unscrew the cap.
2. Loosen axle nut.
3. Fasten axle nut using a torque wrench whilst rotating the ECO hub unit. It should take several turns until the tightening torque has reached 150 Nm.
 - If a normal axle nut spanner is used (vehicle tool kit), tighten the axle nut until the ECO Unit drags slightly (auxiliary solution).
4. If the groove of the axle nut is the same size as a bore hole of the axle stub, the safety bolt must be removed directly. If this action is not performed, the axle nut must be turned back until the next opportunity to secure it (less than 15°).
5. Insert bolt and locking ring.
6. Screw on caps.

Tightening torque:

Steel / cast cap	800 Nm
Aluminium cap	350 Nm

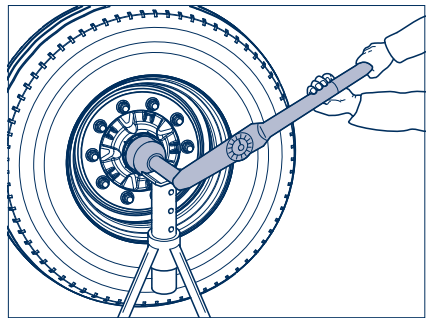
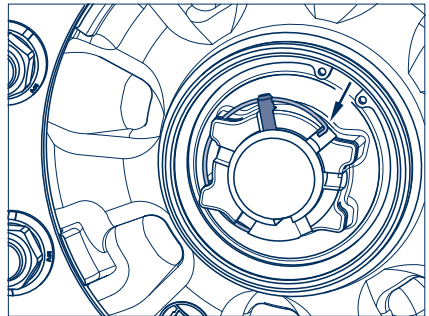
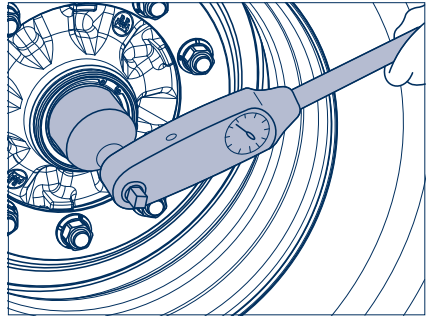

3 BPW Trailer axles / BPW Steering axles

3.2 Maintenance Work and Visual Inspection

3.2.2 Drum brakes

If bearing play is detected
- **conventional hub bearing:**

Adjust the bearing play

1. Unscrew the cap.
2. Remove the split pin from the axle nut.
3. Fasten the axle nut using a torque wrench and with the continuous turning of the wheel hub. It should take several turns until the tightening torque has reached the desired value.

Tightening torques:

hub caps with BPW oval shape:

Up to an axle load of 5.5 tons (up to calendar week 38/2011) = 100 Nm,
from 6 to 18 tons axle load = 150 Nm,

hub caps with octagonal shape:

from 16 to 30 tons axle load = 350 Nm

- If a normal axle nut spanner is used (vehicle tool kit), tighten the axle nut until the wheel bearing race drags slightly.

4. If a groove of the the axle nut is the same size as a bore hole on the axle stub, the safety split pin must be removed directly.

If this action is not performed, the axle nut must be turned back until the next opportunity to secure it (less than 30°). (Does not apply to the ECO Plus 3, ECO Plus 2, ECO^{Plus} and ECO Unit.)

5. Insert the split pin and bend upwards slightly.
6. Refill the cap as required with BPW special longlife grease ECO-Li^{Plus} and replace.

For tightening torques see point [5](#) on page 31.

 For 16 - 18 t axles with BPW oval shape hub cap, a new O-ring must be fitted on reassembly.

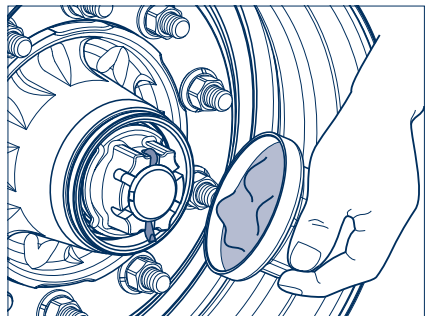
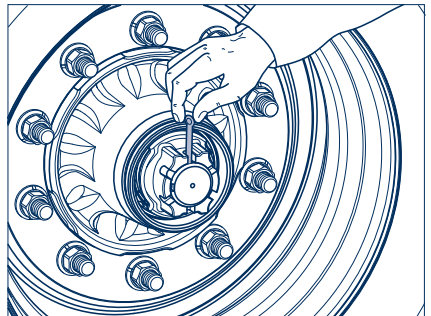
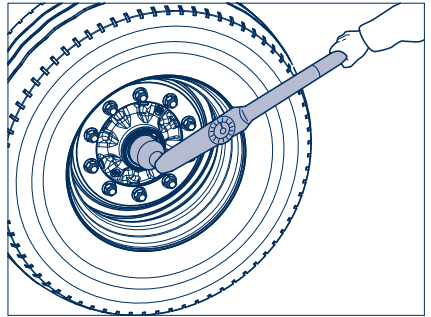

If bearing play is detected
 - **conventional hub bearing up to 5.5 t,
 from calendar week 38/2011:**

Adjust the bearing play

1. Unscrew the cap.
2. Remove the split pin from the axle nut.
3. Tighten the axle nut with a torque wrench at the same time with continuous rotation of the wheel hub. Minimum 5 rotations must be done until a torque of 100 Nm is achieved.
4. Loosen the axle nut with two full turns until the bearing is loosened or relaxed.
5. If necessary screw hub puller. Complete wheel hub unit with BPW hub puller 05.012.25.01.0 and screw 02.5026.50.80 or alternatively retrieve a universal hub puller to relax the bearing.
6. Tighten using 70 Nm axle nut.
7. Check the wheel bearing can run freely. It must be possible to turn the wheel hub evenly and without any noticeable restraint after having been set.
8. Turn back axle nut to the next locking position (min. 3°, max. 15°). Through the asymmetric cap of the axle nut, the next locking position is reached after turning back max. 15°.
9. Insert pin and locking ring.
Take care to ensure the hooked spring ring is located correctly within the axle nut.
10. Mark the position of the axle nut on the axle stub (arrow).
11. Refill the hub cap as required with BPW special longlife grease ECO-Li^{Plus} and replace.
 Tightening torque: 500 Nm

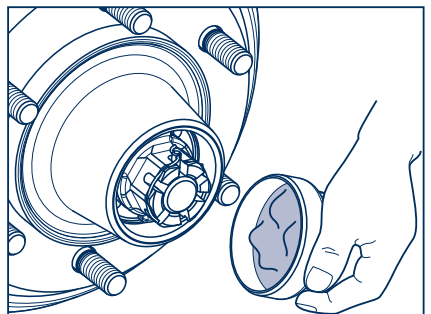
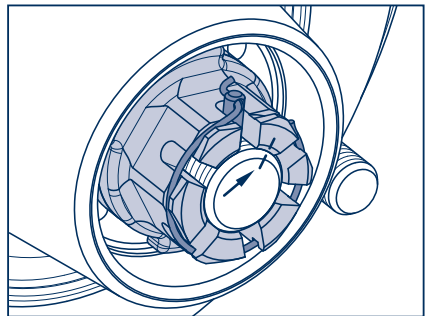
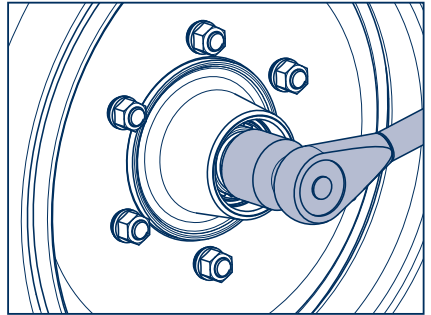

3 BPW Trailer axles / BPW Steering axles

3.2 Maintenance Work and Visual Inspection

3.2.3 Disc brakes, brake types: TS2 / TSB

Overview For detailed description, see pages 42 - 50 Air suspension, see pages 52 - 80 Suspension, see pages 82 - 91	Initially	Every 12 weeks ¹⁾	Every 26 weeks ¹⁾	At every brake lining replacement, latest annually
Maintenance work - Disc brakes Brake type: TS2 3709, TS2 4309 and TSB 3709, TSB 4309, TSB 4312				
<input type="checkbox"/> 1 Check wheel nuts for tightness.	1 ²⁾			
<input type="checkbox"/> 2 Check brake pad thickness.		2		
<input type="checkbox"/> - Visual check, check all components and welding seams for damage, wear and corrosion.			-	
<input type="checkbox"/> 3 Check brake disc thickness and visually check for cracks.		3		
<input type="checkbox"/> 4 Check caliper guide system.		4		
<input type="checkbox"/> 5 TS2: Check bellow with pressure plate. TSB: Check coarse dirt seals and the pressure plates.			5	
<input type="checkbox"/> 6 Check the bearing play of the ECO Unit, adjust if necessary.			6	

¹⁾ Under extreme conditions, increase frequency (e.g. Off-Road, heavy-duty braking work).

²⁾ After the first run under load conditions and likewise after each wheel change.

Note: Components that have damages due to improper mounting are to be exchanged

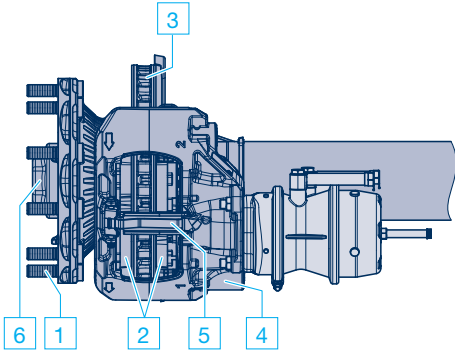

Series SR with disc brakes type TS2

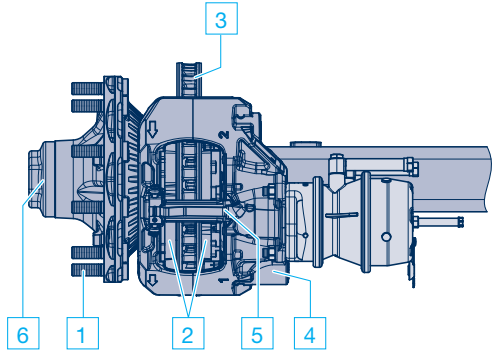

Series SH with disc brakes type TS2

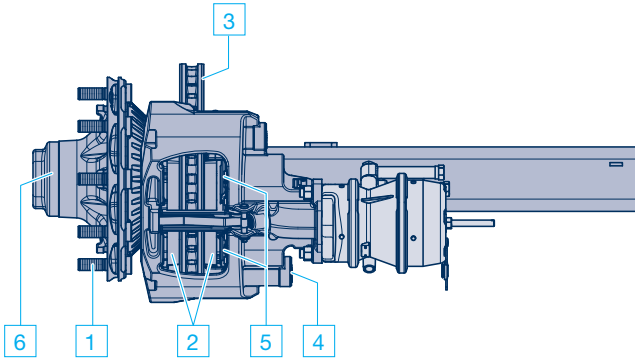

Series SH with disc brakes type TSB

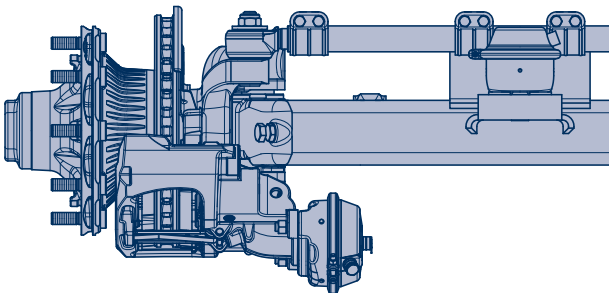

Series LL with disc brakes type TSB

3 BPW Trailer axles / BPW Steering axles

3.2 Maintenance Work and Visual Inspection

3.2.3 Disc brakes, brake types: TS2 / TSB

1 Check wheel nuts for tightness

– the tightening torque of the wheel nuts must be checked after the first laden load journey as well as after each wheel change and, if appropriate, retightened to the prescribed value –

Tighten wheel nuts diagonally using a torque wrench to the correct tightening torque.



It is imperative that the prescribed tightening torques are adhered to in order to ensure the wheels are securely fastened!

The wheel studs must be clean and free of damage and the nuts must be easily tightened and loosened. If needed, lightly oil the contact surface between the wheel nut and the pressure disc. Do not oil or grease the thread of the wheel studs and wheel nuts.

The use of aggressive and acidic rim cleaners is not permitted. Such agents can seriously impair the anti-corrosion coating of wheel bolts and wheel nuts.

Tightening torques for wheel nuts M 22 x 1.5:

Stud alignment : **510 Nm** (485 - 535 Nm)
Spigot alignment: **630 Nm** (600 - 660 Nm)

Attention: Do not exceed specified settings!

Wheel contact surface should not have additional coats of paint (risk of the wheels becoming detached)!

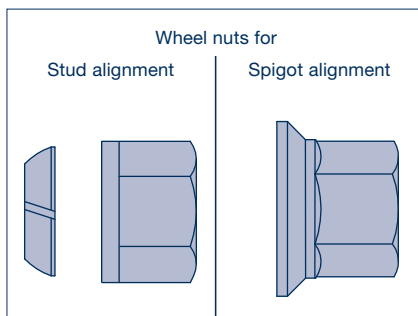
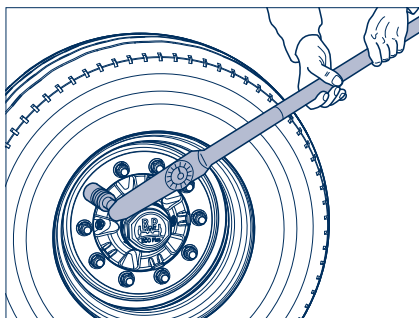

2 Check brake pad thickness

– quarterly –

The brake pad thickness must be checked regularly, e.g. during the tyre inflation pressure check. The intervals must not be more than 3 months.



Worn brake pads reduce braking performance and can ultimately lead to the brakes failing completely!

The brake pad thickness can be checked where the brake caliper interfaces with the welded anchor plate with the wheels mounted (approximate wear indicator).

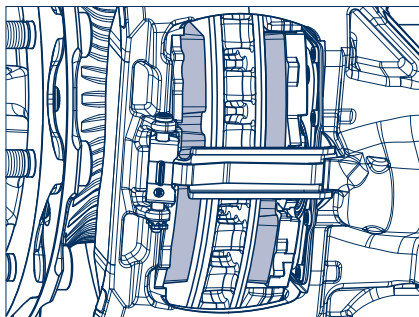

	TS2 3709 4309	TSB 3709 4309	TSB 4312
Dimension x (when new, distance between brake caliper and brake anchor plate)	12 mm	9 mm	9 mm
max. permissible brake pad wear			
19 mm	31 mm	--	28 mm
21 mm	--	30 mm	--
max. permissible wear for brake pad and brake disc	35 mm	34 mm	32 mm

The brake pads must be removed to inspect them more closely - see relevant workshop manual.

Heat affected, glazed over, or oily brake pads must be replaced immediately.

The remaining brake pad thickness must **not** be less than 2 mm (use a caliper gauge for this).

Hairline cracks at the edges are permissible; replacement is required if more sizable surface cracks are present.

 Only ever replace brake linings axle by axle!

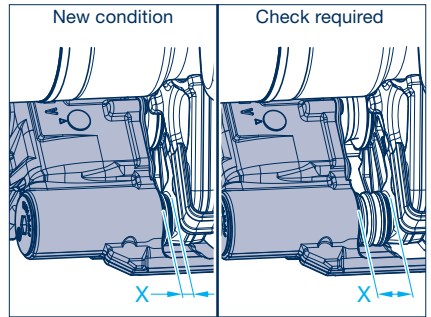

Brake type TS2

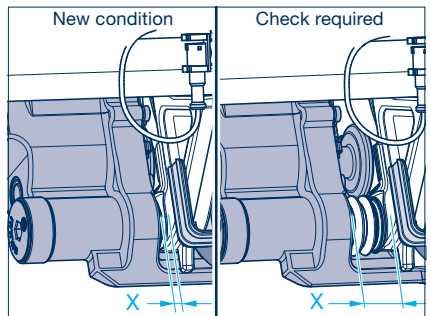

Brake type TSB

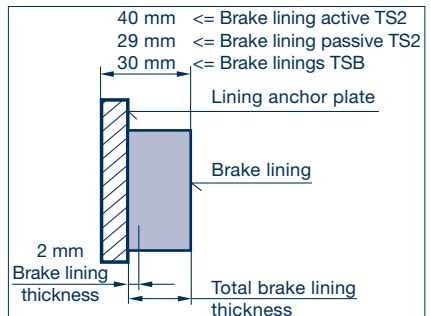

Visual inspection
- every six months -

Check all components and welding seams for damage, wear and corrosion.

3 BPW Trailer axles / BPW Steering axles

3.2 Maintenance Work and Visual Inspection

3.2.3 Disc brakes, brake types: TS2 / TSB

3 Brake disc (Check the condition of the brake disc)

- every 3 months -

Sections **A - D** (see fig.) show the possible conditions of the disc surface:

- A:** Network-type tears = permissible
- B:** Radial cracks up to max. 1.5 mm width and depth = permissible
- C:** Uneven disc surface less than 1.5 mm = permissible
- D:** Continuous cracks = not permissible

Technical details:

- Disc thickness, new = 45 mm
- Minimum permissible disc thickness = 37 mm
- Maximum wear per side = 4 mm
(Use a caliper gauge where the pads make contact)

In the case of surface conditions **A - C**, the brake disc can be used until the minimum permissible disc thickness has been reached.

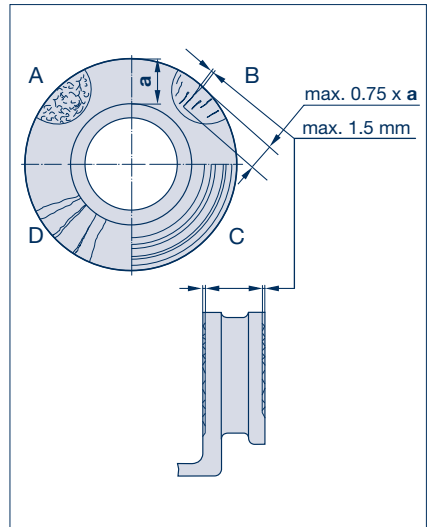

Attention!

To prevent damage to the brake discs, the brake pads should be replaced when the minimum thickness (excluding backing plate) is **2 mm** or less.

Brake discs should always be replaced in pairs. The brake pads should also be replaced when new brake discs are fitted.

If this instruction is not adhered to, there is a danger that with the worn brake pads the brake disc will be damaged and the braking performance could be seriously reduced.

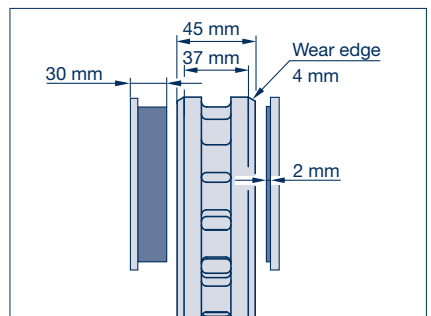

4 Checking the brake caliper guide system (check play and adjustment)

- every 3 months -

Prevent the vehicle from rolling away.
Release the service and parking brakes.

The brake cylinder and fasteners for the brake pads can remain fitted.

Forcefully push the sliding caliper in the axle direction. The caliper must move approximately 0.7 to 1.3 mm (play).

If play is not within this tolerance, the brake caliper guide must be checked and readjusted.

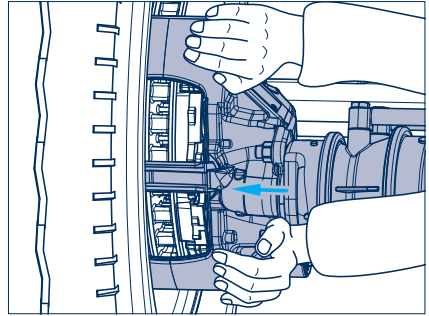

For close inspection of play with wheels mounted:

Use a dial gauge to determine the play. To this end, attach a dial gauge holder to the axle housing and position the button on the outside of the screw plug (1) or on the brake cylinder.

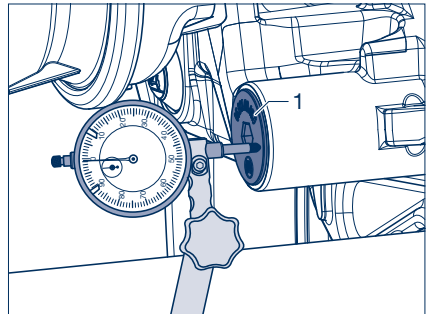

For close inspection of play with wheels removed:

Brake type TS2

Use a feeler gauge to check the clearance. Forcefully push the sliding caliper in the direction of the axle centre. Insert the feeler gauge between the bellow with pressure plate (2) and the brake lining back plate (3).

If play is not within the tolerance required, adjustment must be carried out and the brake caliper guide checked.

Brake type TSB

Check the play using two feeler gauges. Forcefully push the sliding caliper towards the centre of the axle and insert the gauges between the pressure plates (2) and pad backing plate (3).

If play is not within the tolerance required, adjustment must be carried out and the brake caliper guide checked.

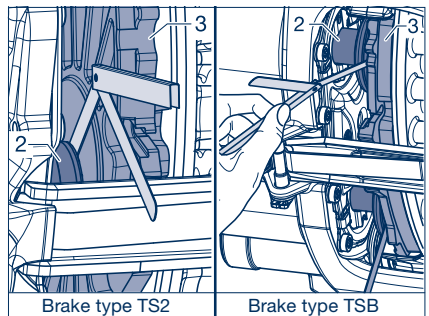

Brake type TS2

Brake type TSB

3 BPW Trailer axles / BPW Steering axles

3.2 Maintenance Work and Visual Inspection

3.2.3 Disc brakes, brake types: TS2 / TSB

Brake type TS2

Set play and check adjustment

1. Remove the plug.
2. Turn the resetter with a spanner (AF 13) **90° counterclockwise**.
3. Actuate the brake 5 to 10 times with a force of approximately 2 bar.
4. Forcefully push the sliding caliper in the axle direction. The play exhibited at this time must be between 0.7 and 1.3 mm.

Adjustment is correct if play is within this tolerance.

5. Squeeze the seal cap (vented) and press it into the brake caliper. Both lamellae of the seal must lie inside of the holder in the brake caliper.

Check brake caliper guide:

The brake caliper guide must be checked if the play was not adjusted properly.

Disassemble the brake linings. It must be possible to move the brake caliper slightly from end stop to end stop.

The guide bushings are sealed by the bellows (4) and the screw plug (1).

Inspect the bellows and sealing plugs for cracks, damage and proper seating and replace if necessary. **Sealing plugs that have been removed must be replaced, not re-used.**

See workshop manual ECO Disc TS2 for information on how to repair the brake caliper guide.

Check the brake caliper bearing play:

The bearing play of the brake caliper can be determined using a dial gauge. Attach the dial gauge holder to the axle beam and position the gauge on the brake caliper housing on the brake cylinder holder.

Press the brake caliper vertically **downwards** to its installation position and set the dial gauge to „zero“.

Press the brake caliper **upwards** and read the bearing play on the dial gauge.

If a brake caliper bearing play exceeds 1.0 mm, the brake caliper bearing must be replaced.

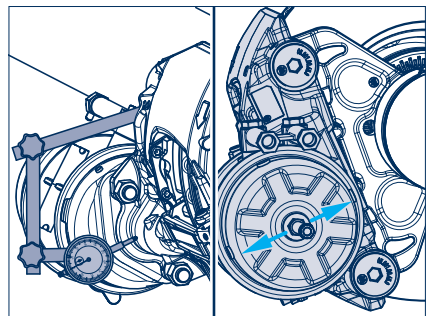
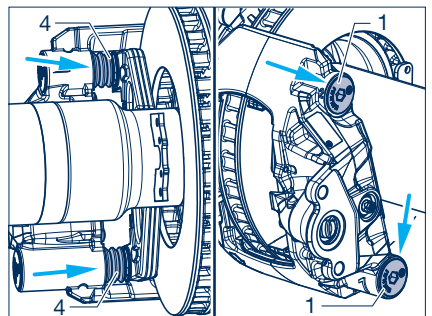
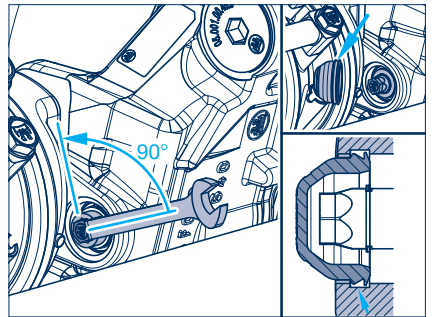

Brake type TSB

Set play and check adjustment

1. Remove the plug.
2. Using a torx wrench (T25), depress the return spring and turn clockwise until it „clicks“ 2 times.
3. Actuate the brake 5 to 10 times with a force of approximately 2 bar.
4. Forcefully push the sliding caliper in the axle direction. The play exhibited at this time must be between 0.7 and 1.3 mm.

Adjustment is correct if play is within this tolerance.

5. Reinsert the plug.

Check brake caliper guide:

The brake caliper guide must be checked if the play was not adjusted properly.

Disassemble the brake linings. It must be possible to move the brake caliper slightly from end stop to end stop.

The guide bushings are sealed by the bellows (4) and the screw plug (1).

Inspect the bellows and sealing plugs for cracks, damage and proper seating and replace if necessary. **Sealing plugs that have been removed must be replaced, not re-used.**

See workshop manual ECO Disc TSB for information on how to repair the brake caliper guide.

Check the brake caliper bearing play:

The bearing play of the brake caliper can be established using a dial gauge. Attach the dial gauge holder to the axle beam and position the gauge, facing the long locating bearing, on the lower edge of the cylinder flange.

Press the brake caliper on the brake cylinder vertically downwards to its installation position and set the dial gauge to „zero“.

Press the brake caliper upwards and read the bearing play on the dial gauge.

If a brake caliper bearing play exceeds 1.5 mm, the brake caliper bearing must be replaced.

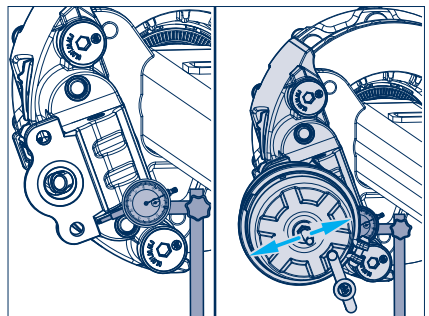
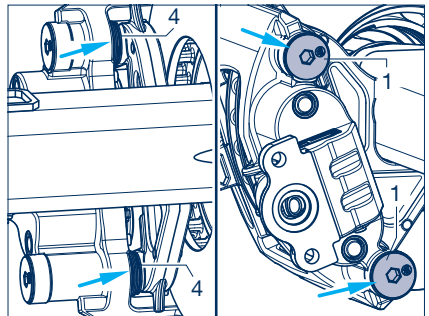
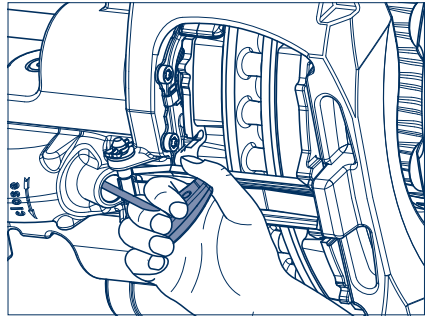

3 BPW Trailer axles / BPW Steering axles

3.2 Maintenance Work and Visual Inspection

3.2.3 Disc brakes, brake types: TS2 / TSB

- 5 TS2:**
Check the bellow with pressure plate
 - every six months -

Prevent the vehicle from rolling away.
 Release the service and parking brakes.

See workshop manual ECO Disc TS2 for information on how to remove the brake pads.

The service brake and spring actuator must be released.

Pull the pressure plate with heat protection cover and bellow (5) out of the dust cover slightly. Check the complete unit for proper seating and damage; replace it if necessary.

Check the dust cover (arrow) for deformation. If a deformation is detected, the brake caliper must be replaced!

If a thermal overloading of the brake has been detected, the bellow with pressure plate (5) must be replaced.

Before the new bellow with pressure plate is installed, the adjusting unit must be checked for corrosion and ease of movement .

After the check or replacement, the bellow must be folded correctly and returned to its initial position. The pressure plate rests against the threaded sleeve.



It is recommended that the pressure plate be replaced each time that the brake disk is changed.

Refer to workshop manual ECO Disc TS2 for details on changing the bellow with pressure plate.



The penetration of dirt and moisture causes corrosion and affects the operation of the clamping mechanism and adjustment.

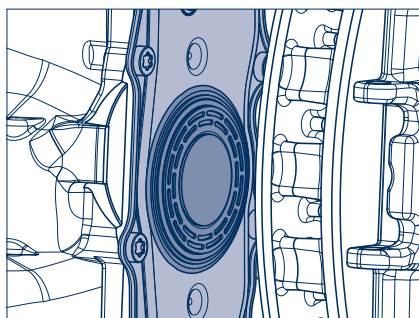
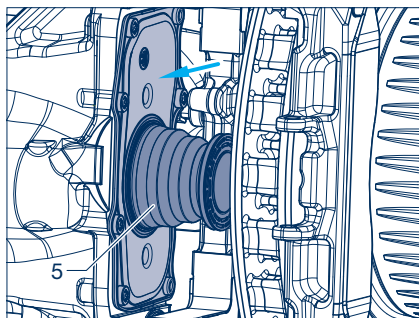

TSB:**Check coarse dirt seals and the tappets**

- every six months -

Prevent the vehicle from rolling away.

Release the service and parking brakes.

See workshop manual ECO Disc TSB for information on how to remove the brake pads.

The service brake and spring actuator must be released.

With a vernier gauge, measure the diameter of the concentric pin on the two thrust pieces.

When it reaches a minimum of 8 mm, change the thrust piece.

To change the thrust piece, see workshop manual ECO Disc TSB.

Unscrew the tappets beyond the adjuster (min. 30 mm) until the coarse dirt seals are plainly visible.

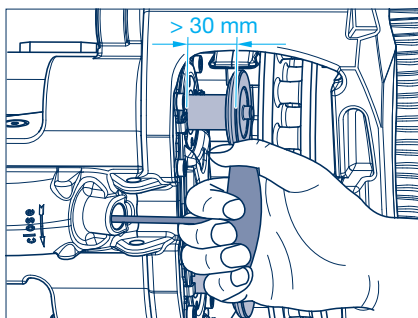
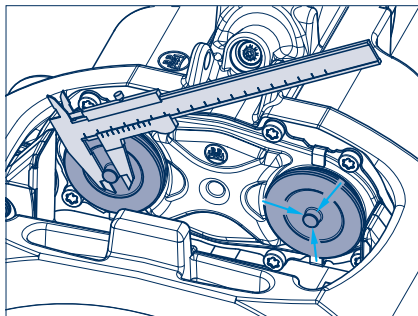

Ensure proper seating.

(Visual inspection, see detail extract)

Check the dust cover of the brake caliper in the area between the coarse dirt seals (arrows) for deformation. If deformation is detected, the brake caliper requires changing!

Note:

Penetrating dirt and damp cause corrosion and affect the operation of the clamping mechanism and adjustment.

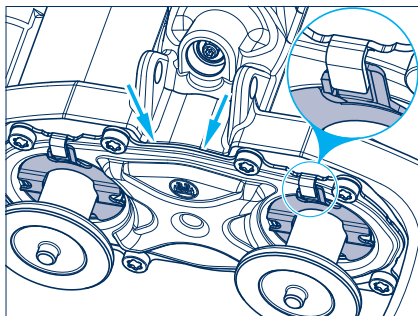

3 BPW Trailer axles / BPW Steering axles

3.2 Maintenance Work and Visual Inspection

3.2.3 Disc brakes, brake types: TS2 / TSB

The bellows must be replaced if thermal overloading was detected.

Only new parts may be used.

The adjustment device must be checked for corrosion and ease of movement before the new parts are installed.

See workshop manual ECO Disc TSB for information on how to replace the bellows.

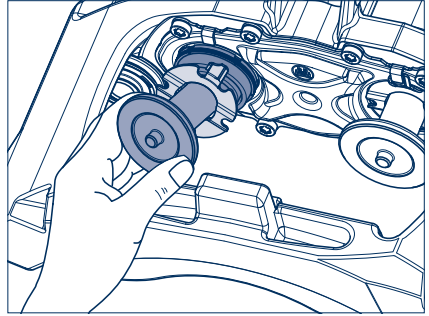

6 Check the bearing play of the ECO Unit - every 6 months -

Prevent the vehicle from rolling away.

In order to check the bearing play of the ECO Unit, lift the axle until the wheels are off the ground. Release the brake. Apply a lever between the tyre and the ground and check the play.

The bearing play must be reset if the bearing play can be felt.

See instructions on setting bearings for ECO Plus 3, ECO Plus 2 and ECO^{Plus}, pages 33 to 36.

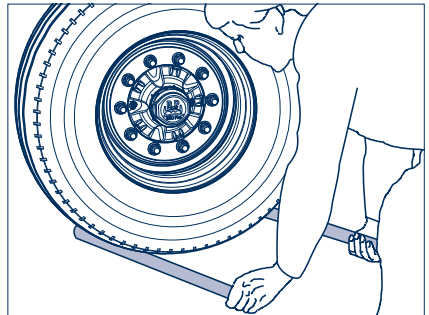

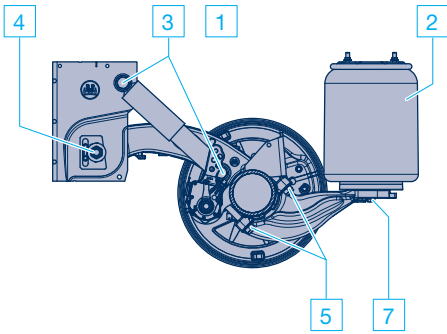

Serie EABO

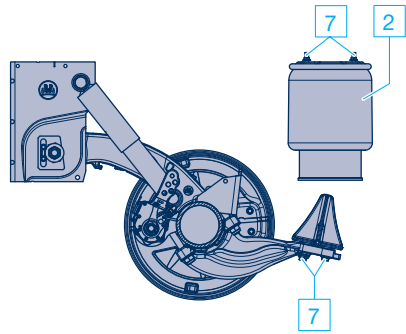

Serie EABO with Kombi-Air Bag II

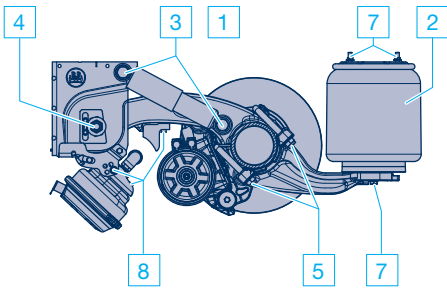

**Series EAAM / EABM
with two-sided axle lift**

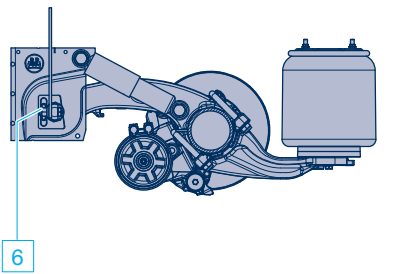

Serie EABM with bolt-on gusset plate

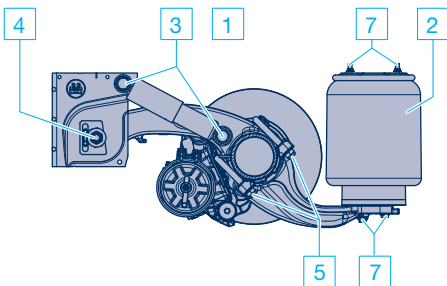

Serie EAAU

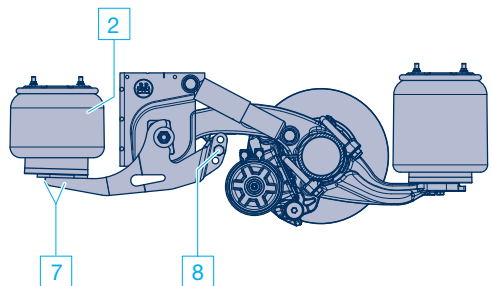

Serie EAAM with side mounted axle lift

4 BPW Air suspension, series EA

4.2 Maintenance Work and Visual Inspection

1 Air installation circuit – Service intervals as shown on page 52 –

Check air installation valves and line connections for firm seating, damage and seal tightness.
Check valve linkage and fastenings (arrows) for damage and tightness.

The length of the valve lever and permissible angular positions for the valve linkage are shown in the illustration below.

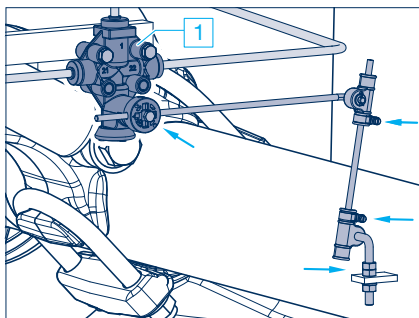

Air suspension valve

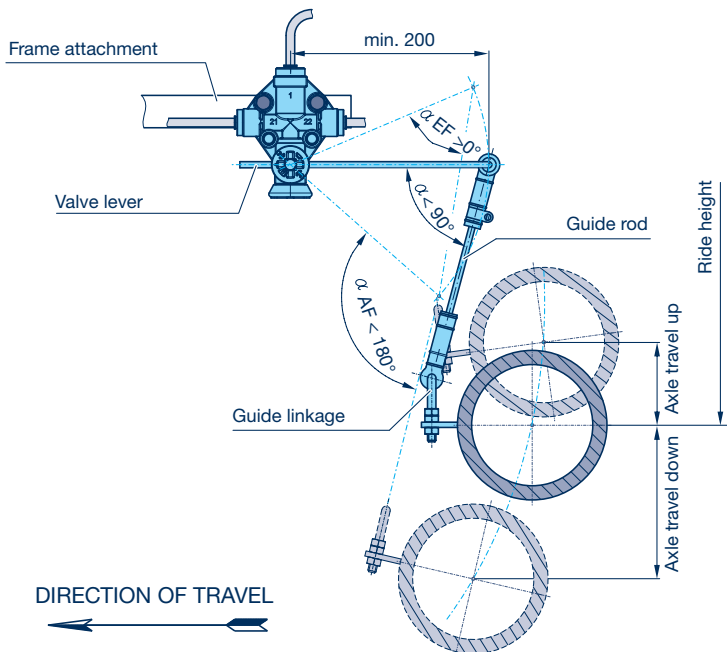

2 Air bags

– Service intervals as shown on page 52 –

Check air bags for external damage (surface cracking, abrasion, crease formation, trapped foreign bodies etc.). Replace air bags in the event of damage.

⚠ Safety notice

No welding should be carried out on steel parts of air bags and pressure vessel!

The air suspension should only be filled with compressed air when mounted.
Danger of injury!

- Visual inspection

– Service intervals as shown on page 52 –

Check all component parts and welding seams for wear and damage.

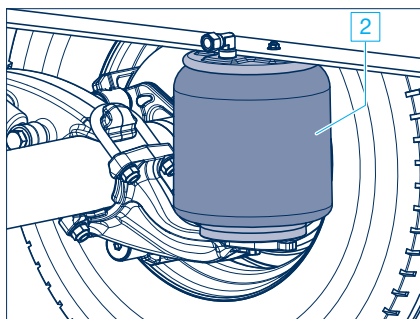

3 Shock absorber fastening

– Service intervals as shown on page 52 –

Check lower and upper shock absorber fastening for tightness.

Check condition and wear of the rubber bush and replace where appropriate.

Check shock absorbers for oil leakage. In cases of distinct traces of oil, the shock absorber must be replaced. A light mist of oil is acceptable!

Tightening torques with a torque wrench:
M 24 (SW 36) M = **420 Nm** (390 - 460 Nm)

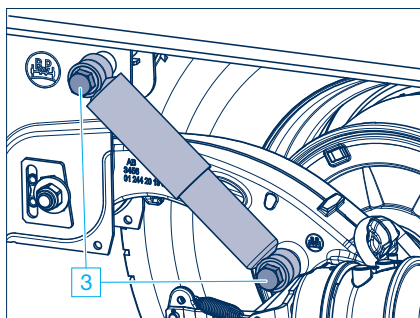

4 BPW Air suspension, series EA

4.2 Maintenance Work and Visual Inspection

4 Spring pivot bolts – Service intervals as shown on page 52 –

Check bushes; move vehicle back and forth slightly with brakes applied or move spring eyes with assembly lever with brakes released. No play should be present in the rolled spring end when doing so. If the fastening is loose the spring pivot bolt may be damaged.

- Check the lateral wear washers in the hanger bracket.
- Check the M 24 lock nut on the spring pivot bolt for tightness.

Tightening torque with a torque wrench:
M 24 (SW 36) M = **650 Nm** (605 - 715 Nm)

The life expectancy of the bearing depends on the tightness of the spring bolt or the inner bush.

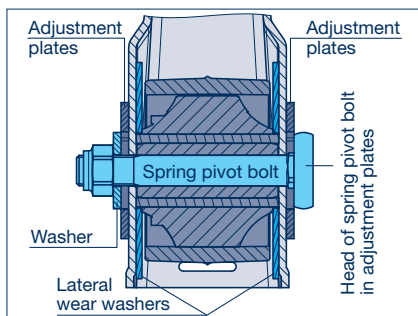
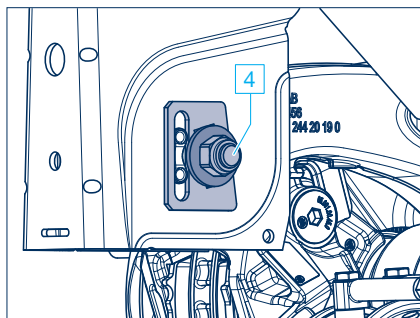

5 Axle clamping – Service intervals as shown on page 52 –

Check lock nuts of spring U-bolts for tightness. If loose, tighten nuts alternately a little at a time.

Tightening torques with a torque wrench:
M 20 (SW 30) M = **450 Nm**

When mounting new spring mounting kit components, tighten the M 20 locknuts to a tightening torque of: M = **450 Nm + 90°** angle tightening.

 **Note:** Do not weld on the trailing arms and the bellows support!

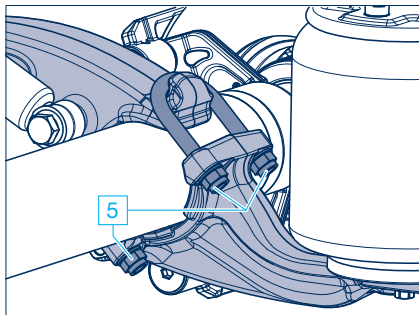

6 Bolted connection, gusset plate spring bolts

– Service intervals as shown on page 52 –

Check the mounting bolts of the gusset plates on the spring bolts are firmly tightened, and retighten with a torque wrench if necessary.

Tightening torque:

M 18 (SW 27) M = **420 Nm** (390 - 460 Nm)

Installing or renewing the spring bolt:

1. Unscrew or install the spring bolt.
2. Loosely pre-mount the gusset plate with at least three M 16 bolts at the top on the crossmember and one M 18 bolt at the bottom on the spring bolt and tighten further until contact is made.
3. Set the track.
4. Tighten the spring bolt to the prescribed tightening torque.
5. Tighten the connecting bolt on the gusset plates spring bolt and then tighten the upper connecting bolt to the prescribed tightening torques.

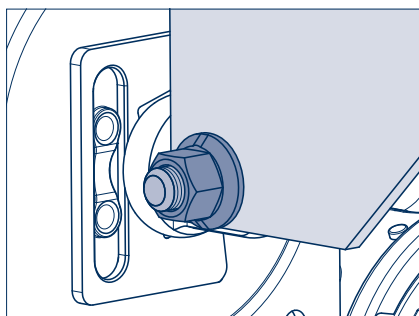
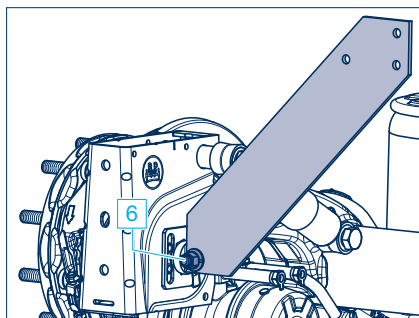

7 Air bag fastenings

– Service intervals as shown on page 52 –

Check air bag fixing bolts or nuts for tightness. If necessary, retighten.

Tightening torques with a torque wrench:

M 12 (SW 17) M = 66 Nm
M 16 (SW 22) M = 200 - 230 Nm

Lower attachment - centre screw:

M 16 (SW 22) M = 300 Nm

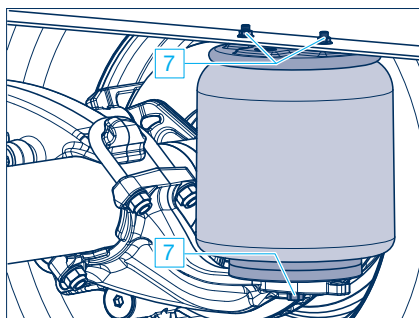

4 BPW Air suspension, series EA

4.2 Maintenance Work and Visual Inspection

8 Axle lift

– Service intervals as shown on page 52 –

Sidewise mounted axle lift:

Check for tight fitting of the M 20 lock nut of the roller mounting on the lifting arm, if necessary tighten with a torque wrench.

Tightening torque:

M 20 (SW 30) M = **350 Nm** (325 - 385 Nm)

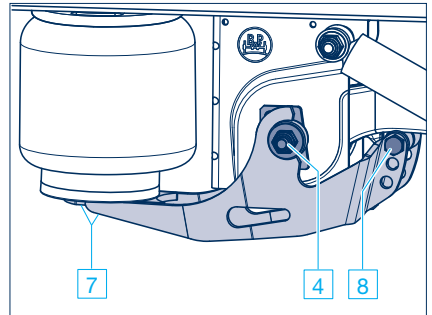

Two-sided lift:

a) Check the M 16 lock nuts on the diaphragm cylinder to make sure they are tight. Tighten with a torque wrench if necessary.

Tightening torque:

M 16 (SW 24) M = **190 Nm** (180 - 210 Nm)

b) Check for tight seating of the bump stop fixing screws on the trailing arms.

Tightening torque:

M 10 (SW 8) M = 50 Nm

c) Check for tight seating of the bracket fixing screws on the shaped plate.

Tightening torque:

M 12 (SW 17) M = 75 Nm

d) Check the lock nut on the bolt for tightness.

Tightening torque:

M 10 (SW 16) M = 38 Nm

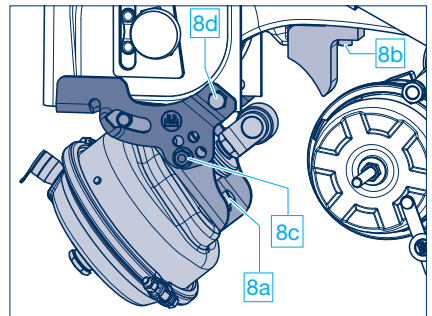

Spring pivot bolt bearing with axle lift

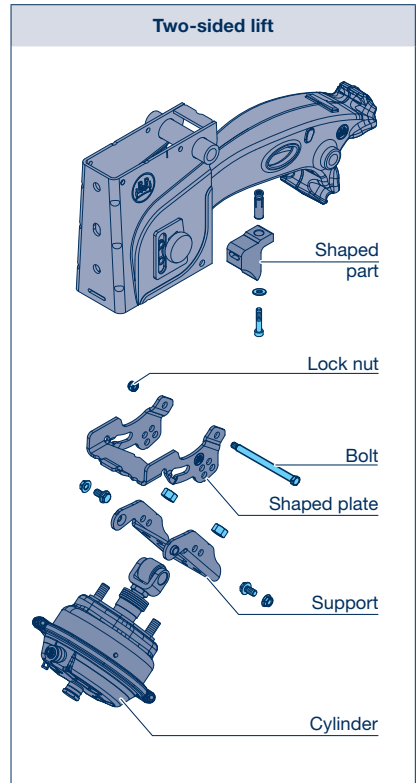
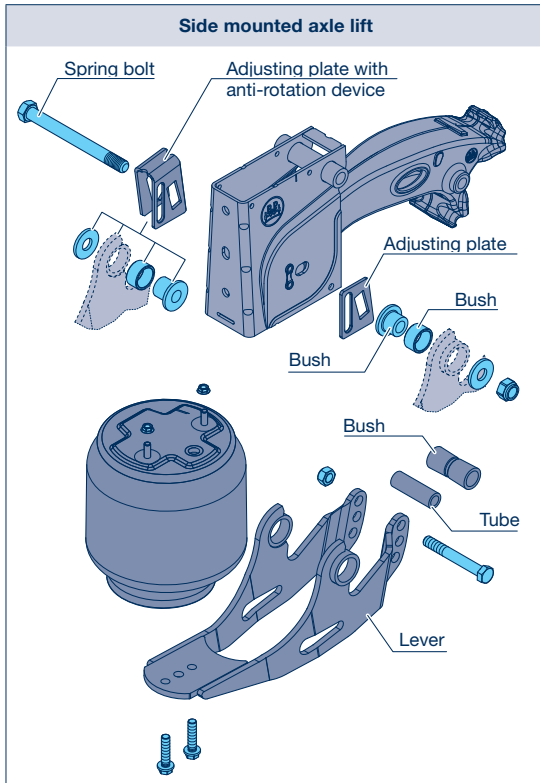

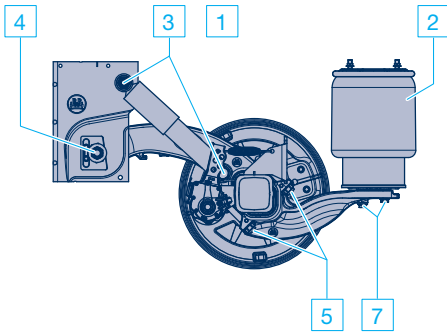

Serie ACBO

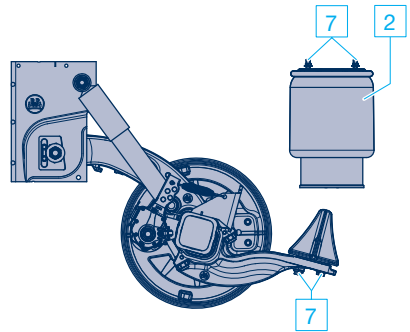

Serie ACBO with Kombi-Air Bag II

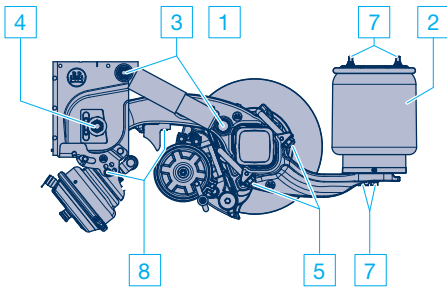

**Serie ACAM / ACBM
with two-sided axle lift**

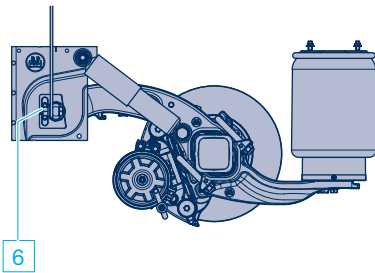

Serie ACBM with bolt-on gusset plate

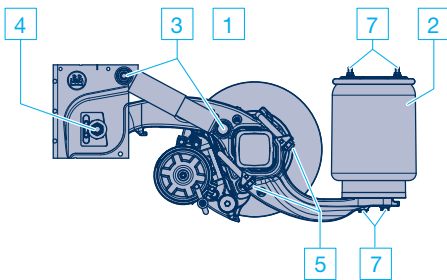

Serie ACAU

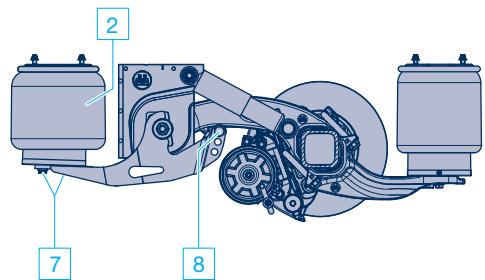

Serie ACAM with side mounted axle lift

5 BPW Air suspension, series EAC

5.2 Maintenance Work and Visual Inspection

1 Air installation circuit

– Service intervals as shown on page 60 –

Check air installation valves and line connections for firm seating, damage and seal tightness.
Check valve linkage and fastenings (arrows) for damage and tightness.

The length of the valve lever and permissible angular positions for the valve linkage are shown in the illustration below.

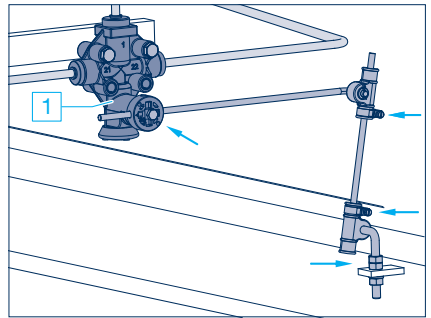

Air suspension valve

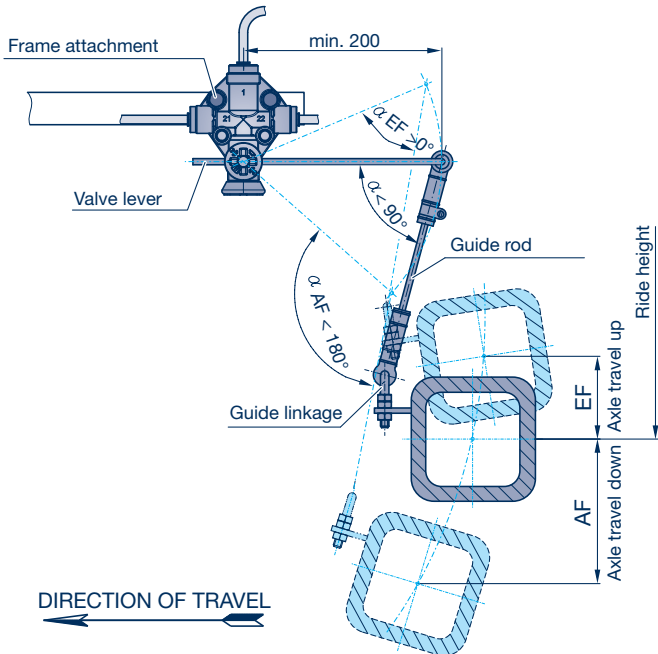

2 Air bags

– Service intervals as shown on page 60 –

Check air bags for external damage (surface cracking, abrasion, crease formation, trapped foreign bodies etc.). Replace air bags in the event of damage.

⚠ Safety notice

No welding should be carried out on steel parts of air bags and pressure vessel!

The air suspension should only be filled with compressed air when mounted.

Danger of injury!

- Visual inspection

– Service intervals as shown on page 60 –

Check all component parts and welding seams for wear and damage.

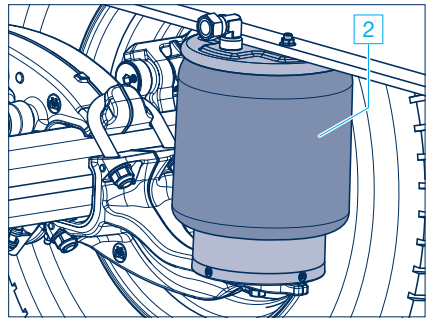
**3 Shock absorber fastening**

– Service intervals as shown on page 60 –

Check lower and upper shock absorber fastening for tightness.

Check condition and wear of the rubber bush and replace where appropriate.

Check shock absorbers for oil leakage. In cases of distinct traces of oil, the shock absorber must be replaced. A light mist of oil is acceptable!

Tightening torques with a torque wrench:
M 24 (SW 36) M = **420 Nm** (390 - 460 Nm)

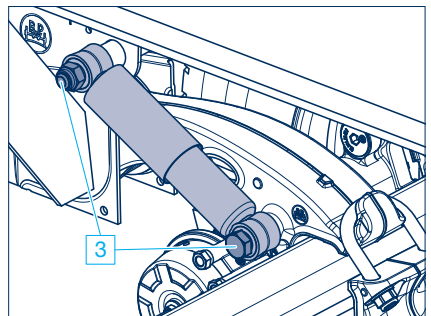

5 BPW Air suspension, series EAC

5.2 Maintenance Work and Visual Inspection

- 4 Spring pivot bolts**
– Service intervals as shown on page 60 –

Check bushes; move vehicle back and forth slightly with brakes applied or move spring eyes with assembly lever with brakes released. No play should be present in the rolled spring end when doing so. If the fastening is loose the spring pivot bolt may be damaged.

- Check the lateral wear washers in the hanger bracket.
- Check the M 24 lock nut on the spring pivot bolt for tightness.

Tightening torque with a torque wrench:
M 24 (SW 36) **M = 650 Nm** (605 - 715 Nm)

The life expectancy of the bearing depends on the tightness of the spring bolt or the inner bush.

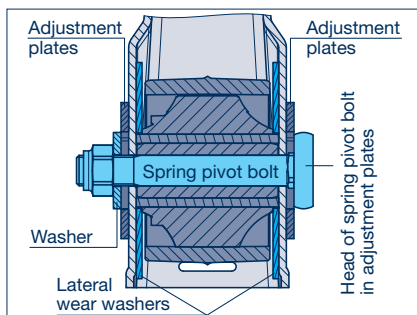
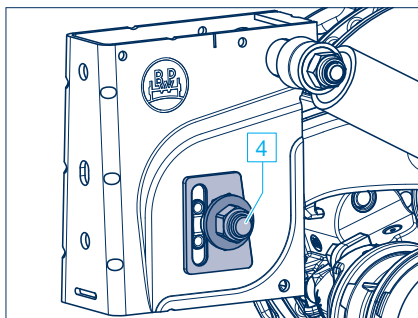

- 5 Axle clamping**
– Service intervals as shown on page 60 –

Check lock nuts of spring U-bolts for tightness. If loose, tighten nuts alternately a little at a time.

Tightening torques with a torque wrench:
M 20 (SW 30) **M = 420 Nm**

When mounting new spring mounting kit components, tighten the M 20 locknuts to a tightening torque of: **M = 420 Nm + 90°** angle tightening.

-  **Note:** Do not weld on the trailing arms and the bellows support!

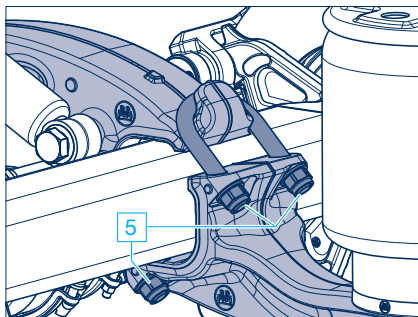

6 Bolted connection, gusset plate spring bolts

– Service intervals as shown on page 60 –

Check the mounting bolts of the gusset plates on the spring bolts are firmly tightened, and retighten with a torque wrench if necessary.

Tightening torque:

M 18 (SW 27) M = **420 Nm** (390 - 460 Nm)

Installing or renewing the spring bolt:

1. Unscrew or install the spring bolt.
2. Loosely pre-mount the gusset plate with at least three M 16 bolts at the top on the crossmember and one M 18 bolt at the bottom on the spring bolt and tighten further until contact is made.
3. Set the track.
4. Tighten the spring bolt to the prescribed tightening torque.
5. Tighten the connecting bolt on the gusset plates spring bolt and then tighten the upper connecting bolt to the prescribed tightening torques.

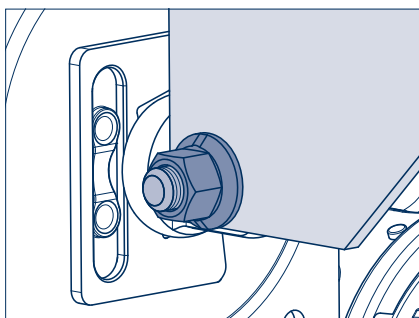
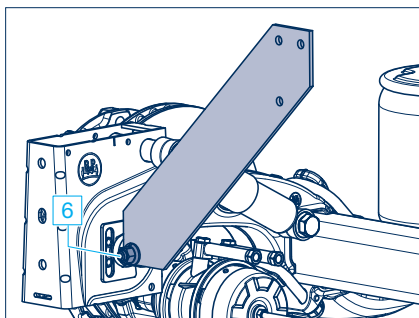

7 Air bag fastenings

– Service intervals as shown on page 60 –

Check air bag fixing bolts or nuts for tightness. If necessary, retighten.

Tightening torques with a torque wrench:

M 12 (SW 17) M = 66 Nm
M 16 (SW 22) M = 200 - 230 Nm

Lower attachment - centre screw:

M 16 (SW 22) M = 300 Nm

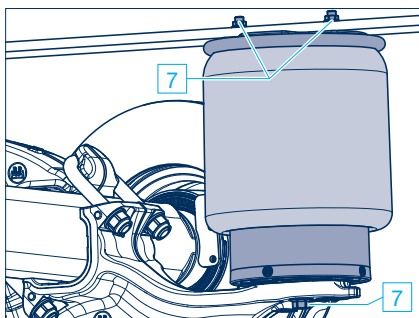

5 BPW Air suspension, series EAC

5.2 Maintenance Work and Visual Inspection

8 Axle lift

– Service intervals as shown on page 60 –

Sidewise mounted axle lift:

Check for tight fitting of the M 20 lock nut of the roller mounting on the lifting arm, if necessary tighten with a torque wrench.

Tightening torque:

M 20 (SW 30) M = **350 Nm** (325 - 385 Nm)

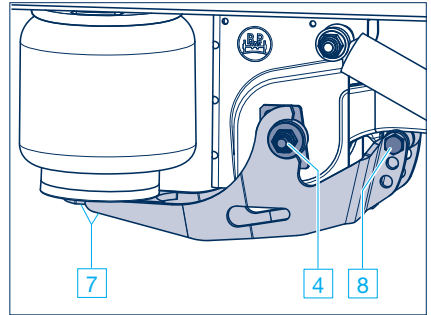

Two-sided lift:

a) Check the M 16 lock nuts on the diaphragm cylinder to make sure they are tight. Tighten with a torque wrench if necessary.

Tightening torque:

M 16 (SW 24) M = **190 Nm** (180 - 210 Nm)

b) Check for tight seating of the bump stop fixing screws on the trailing arms.

Tightening torque:

M 10 (SW 8) M = 50 Nm

c) Check for tight seating of the bracket fixing screws on the shaped plate.

Tightening torque:

M 12 (SW 17) M = 75 Nm

d) Check for the correct seating of the bolt circlip on the rear attachment support of the air suspension hanger brackets.

For versions from 2016, check for tight seating of lock nut.

M 10 (SW 16) M = 38 Nm

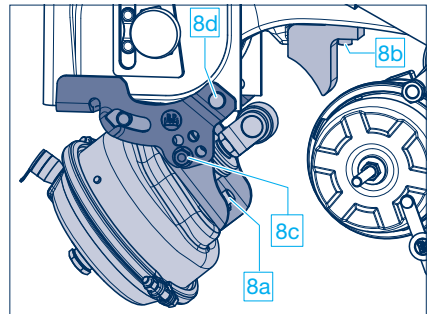

Spring pivot bolt bearing with axle lift

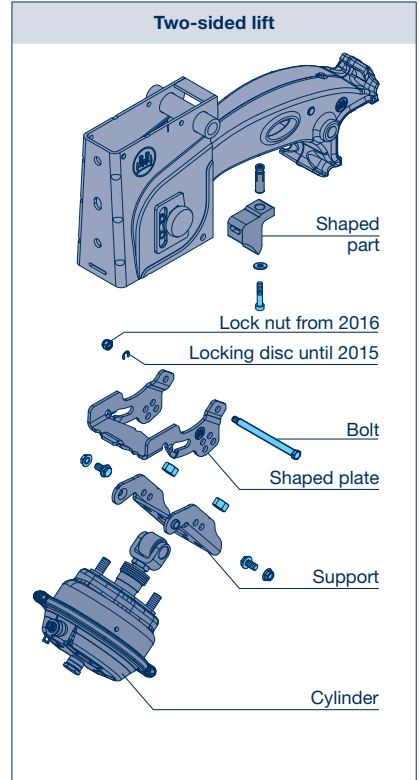
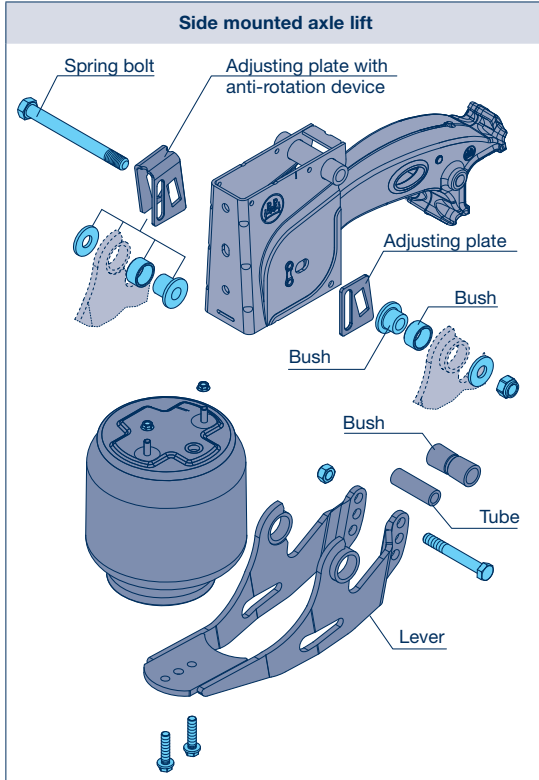

6 BPW Air suspension, series SL / AL

6.1 Overview, Lubrication and Maintenance Work, Visual Inspection

Overview For detailed description, see pages 72 - 80 Air suspension series EA, see pages 52 - 59 Air suspension series EAC, see pages 60 - 67 Suspension, see pages 82 - 91	Within 2 weeks of first journey under load, between 1000km and 5000km	Visual checks during the warranty period for chassis fitted with ECO Plus air suspension - every 6 months -
① Grease stabilizer bearing bushes with BPW special longlife grease ECO-Li ^{Plus} and check for wear.	①	
- Visual inspection, check all component parts and welding seams for damage and wear.		- ²⁾
1 Check strap: Check condition and fastening.		1 ²⁾
2 Check air suspension levelling valve for condition, seal-tightness and general tightness.		2 ²⁾
3 Check condition of air bags.		3 ²⁾
4 Check shock absorber fastening for tightness. Tightening torque with a torque wrench: M 20 (SW 30) M = 320 Nm (300 - 350 Nm) M 24 (SW 36) M = 420 Nm (390 - 460 Nm) For aluminium hanger brackets: M 24 (SW 36) M = 320 Nm (300 - 350 Nm)	4	4 ²⁾
5 Check spring pivot bolts for tightness. Tightening torque with a torque wrench: Hanger brackets and channel crossmember Airlight II from 09/2007: M 24 (SW 36) M = 650 Nm (605 - 715 Nm) Hanger brackets from 8/2001: M 30 (SW 46) M = 900 Nm (840 - 990 Nm) Hanger brackets up to 7/2001: M 30 (SW 46) M = 750 Nm (700 - 825 Nm) Channel crossmember: M 30 (SW 46) M = 900 Nm (840 - 990 Nm)	5	5 ²⁾
6 Check spring mounting kit for tightness. Tightening torque with a torque wrench: M 20 (SW 30) M = 340 Nm (315 - 375 Nm) M 22 (SW 32) M = 550 Nm (510 - 605 Nm) M 24 (SW 36) M = 650 Nm (605 - 715 Nm) When mounting new spring mounting kits for Airlight II: M 22 (SW 32) M = 550 Nm + 90° angle tightening	6 6 6 ¹⁾	6 ²⁾

¹⁾ ECO Plus Units with Airlight II and Airlight Direct air suspension are maintenance-free in On-Road applications and do not need to be retightened (see warranty documents ECO Plus).

²⁾ Under extreme conditions, with more frequency.

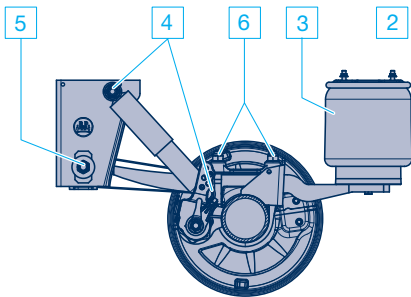

Serie ALO

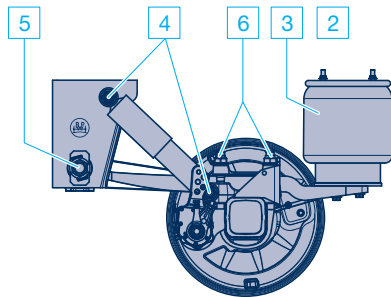

Series ALO/SLO

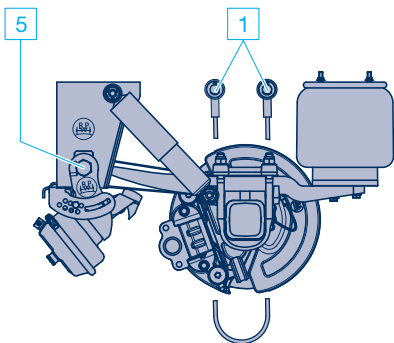

**Series ALO/SLO
with two-sided axle lift**

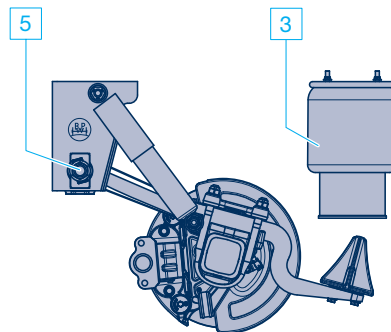

**Series ALM/SLM
with Kombi-Air Bag II**

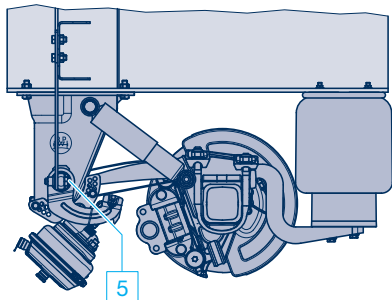

**Series ALM/SLM
with bolted-on air suspension hanger
bracket and bolt-on double-sided lift**

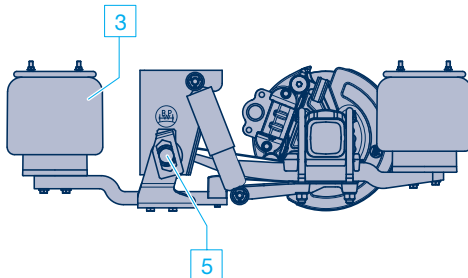

**Series ALU/SLU
with sidewise mounted axle lift**

6 BPW Air suspension, series SL / AL

6.1 Overview, Lubrication and Maintenance Work, Visual Inspection

Overview For detailed description, see pages 72 - 80 Air suspension series EA, see pages 52 - 59 Air suspension series EAC, see pages 60 - 67 Suspension, see pages 82 - 91	Within 2 weeks of first journey under load, between 1000km and 5000km	Visual checks during the warranty period for chassis fitted with ECO Plus air suspension - every 6 months -
7 Check the bolt connection between the air suspension hanger bracket and the longitudinal member for tightness. Tightening torques with a torque wrench: M 16 M = 260 Nm (240 - 285 Nm)	7	7 ²⁾
8 Tighten the spring bolt to gusset plate connecting bolt. Tightening torques with a torque wrench: M 18 x 1.5 (SW 27) M = 420 Nm (390 - 460 Nm)	8	8 ²⁾
9 Check axle lift for tightness. Tightening torques with a torque wrench: Cylinder M 20 (SW 30) M = 350 - 380 Nm M 16 (SW 24) M = 180 - 210 Nm Supporting arm M 16 (SW 22) M = 230 Nm Hexagon screw M 12 (SW 17) M = 75 Nm	9	9 ²⁾
10 Check air bag fastening for tightness. Tightening torques with a torque wrench: M 12 (SW 17) M = 66 Nm M 16 (SW 22) M = 230 - 300 Nm Lower attachment - centre screw M 16 (SW 22) M = 300 Nm	10	10 ²⁾
11 Check stabilizer fastenings. Tightening torques with a torque wrench: M 10 (SW 17) M = 53 Nm M 30 (SW 46) M = 750 Nm (700 - 825 Nm)	11	11 ²⁾

¹⁾ ECO Plus Units with Airlight II and Airlight Direct air suspension are maintenance-free in On-Road applications and do not need to be retightened (see warranty documents ECO Plus).

²⁾ Under extreme conditions, with more frequency.

Note:

Components that have damage due to improper mounting are to be exchanged

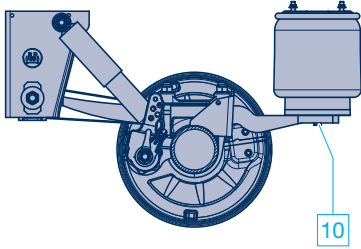

Serie ALO

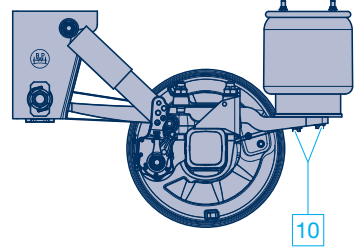

Series ALO/SLO

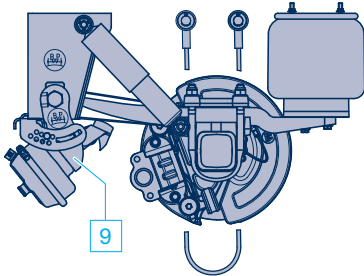

**Series ALO/SLO
with two-sided axle lift**

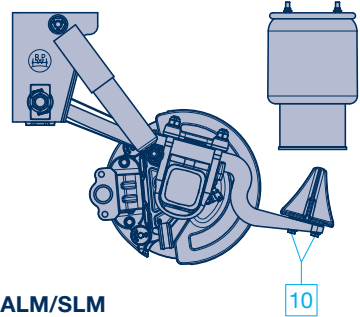

**Series ALM/SLM
with Kombi-Air Bag II**

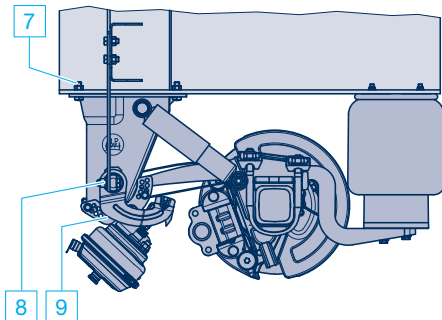

**Series ALM/SLM
with bolted-on air suspension hanger
bracket and bolt-on double-sided lift**

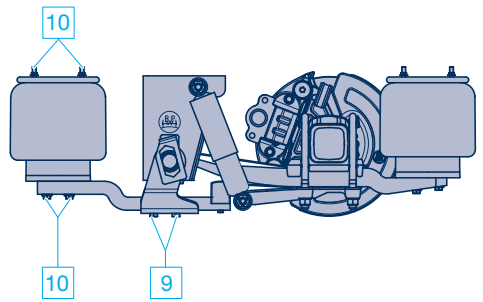

**Series ALU/SLU
with sidewise mounted axle lift**

6 BPW Air suspension, series SL / AL

6.2 Lubrication

6.3 Maintenance Work and Visual Inspection

① Stabilizer bearing bushes

– Service intervals as shown on page 68 –

Grease stabilizer bearing bushes with BPW special longlife grease ECO-LI^{Plus} and check for wear.

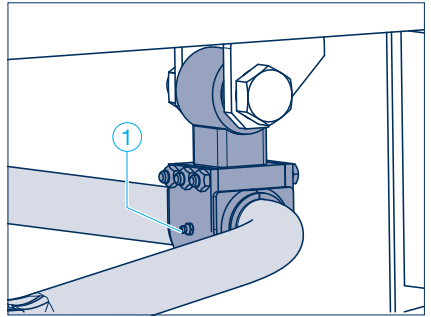

[-] Visual inspection

– Service intervals as shown on page 68 –

Check all component parts and welding seams for wear and damage.

① Check straps

– Service intervals as shown on page 68 –

Examine check straps and attachment. Replace if necessary.

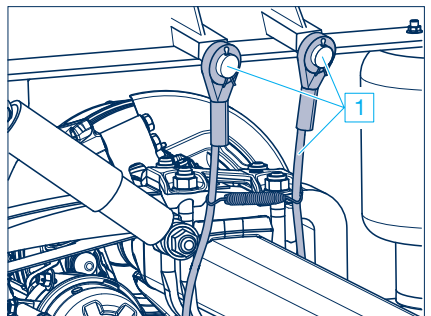

2 Air installation circuit

– Service intervals as shown on page 68 –

Check air installation valves and line connections for firm seating, damage and seal tightness.
Check valve linkage and fastenings (arrows) for damage and tightness.

The length of the valve lever and permissible angular positions for the valve linkage are shown in the illustration below.

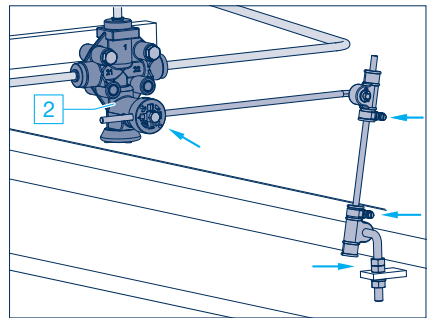

Air suspension valve

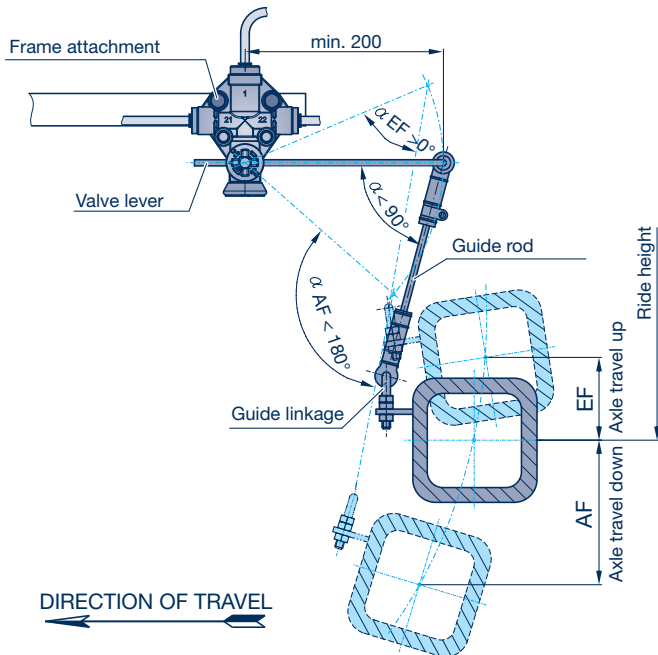

6 BPW Air suspension, series SL / AL

6.3 Maintenance Work and Visual Inspection

3 Air bags

– Service intervals as shown on page 68 –

Check air bags for external damage (surface cracking, abrasion, crease formation, trapped foreign bodies etc.). Replace air bags in the event of damage.

Safety notice

No welding should be carried out on steel parts of air bags and pressure vessel!

The air suspension should only be filled with compressed air when mounted.
Danger of injury!

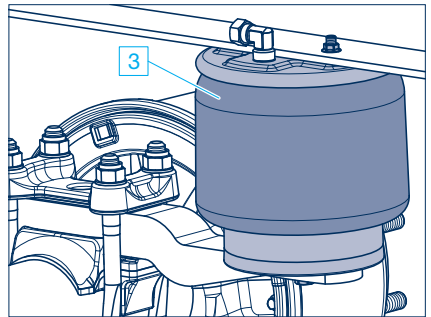

4 Shock absorber fastening

– Service intervals as shown on page 68 –

Check lower and upper shock absorber fastening for tightness. Tightening torques with a torque wrench.

Check condition and wear of the rubber bush and replace where appropriate.

Check shock absorbers for oil leakage. In cases of distinct traces of oil, the shock absorber must be replaced. A light mist of oil is acceptable!

Tightening torque:

M 20 (SW 30) M = **320 Nm** (300 - 350 Nm)

M 24 (SW 36) M = **420 Nm** (390 - 460 Nm)

In the case of aluminium hanger brackets:

M 24 (SW 36) M = **320 Nm** (300 - 350 Nm)

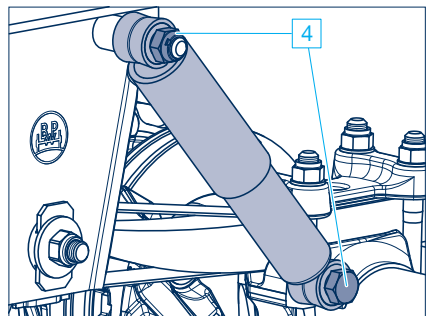

Shock absorber fastening - round axle beam

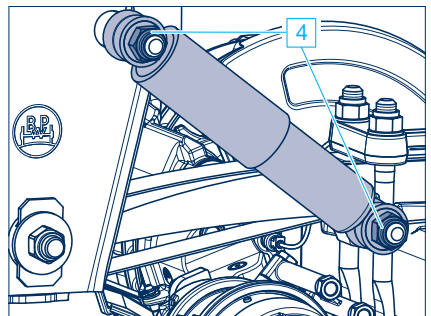

Shock absorber mounting - square axle beam

5 Spring pivot bolts

– Service intervals as shown on page 68 –

Check bushes, move vehicle back and forth slightly with the brake applied, or move rolled spring ends with the aid of a lever. No play should be present in the rolled spring end when doing so. If the fastening is loose the spring pivot bolt may be damaged.

- Check the lateral wear washers in the hanger bracket.
- Check the M 24 or M 30 lock nut on the spring pivot bolt for tightness.

Tightening torque with a torque wrench:

Air suspension hanger brackets and channel crossmember from 09/2007:

M 24 (SW 36) M = **650 Nm** (605 - 715 Nm)

Hanger brackets from 08/2001:

M 30 (SW 46) M = **900 Nm** (840 - 990 Nm)

Hanger brackets up to 07/2001:

M 30 (SW 46) M = **750 Nm** (700 - 825 Nm)

Channel crossmember:

M 30 (SW 46) M = **900 Nm** (840 - 990 Nm)

The serviceable life of the rubber / steel bush is dependent on the tightness of the inner steel bushing.

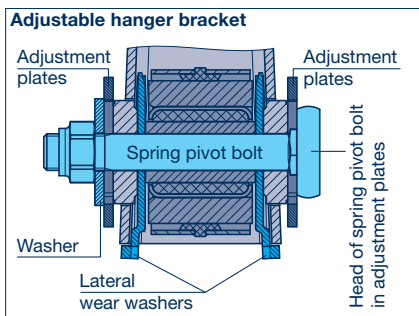
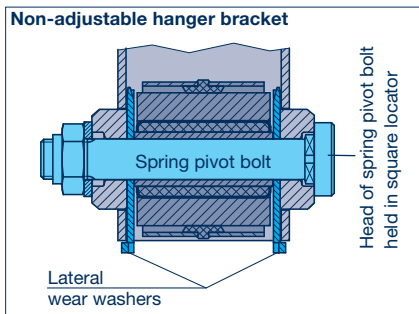
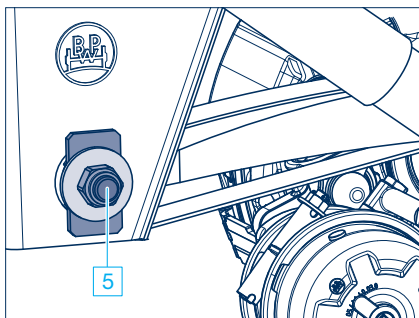

6 BPW Air suspension, series SL / AL

6.3 Maintenance Work and Visual Inspection

- 6 Spring mounting kit**
– Service intervals as shown on page 68 –

Check lock nuts of spring U-bolts for tightness. If loose, tighten nuts alternately a little at a time.

Tightening torques with a torque wrench:

M 20 (SW 30) M = **340 Nm** (315 - 375 Nm)

M 22 (SW 32) M = **550 Nm** (510 - 605 Nm)

M 24 (SW 36) M = **650 Nm** (605 - 715 Nm)

When mounting new spring mounting kit components for Airlight II, tighten the M 22 locknuts to a tightening torque of:

M = 550 Nm + 90° angle tightening.

-  **Note:** No welding should be performed on the trailing arm spring!

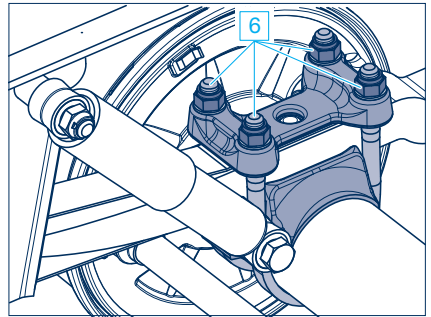

Airlight II with round axle beam

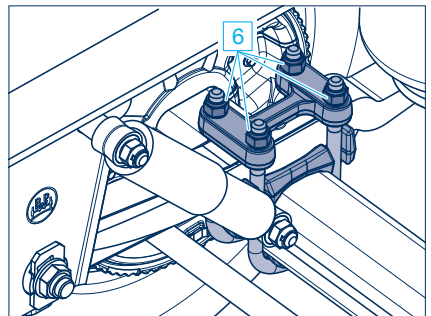

Airlight II with square axle beam

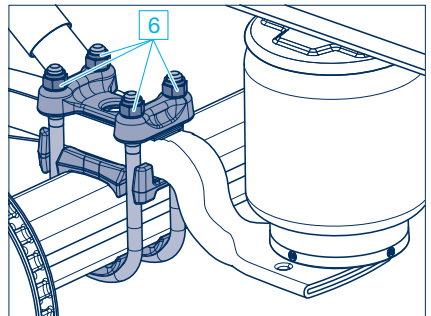

Airlight II with square axle beam and LightTube

7 Bolted connection, air suspension hanger bracket to longitudinal chassis beam

– Service intervals as shown on page 70 –

Check that the mounting bolts of the air suspension hanger bracket on the longitudinal member are firmly tightened.

Tighten with a torque wrench if necessary.

Tightening torque:

M 16 M = **260 Nm** (240 - 285 Nm)

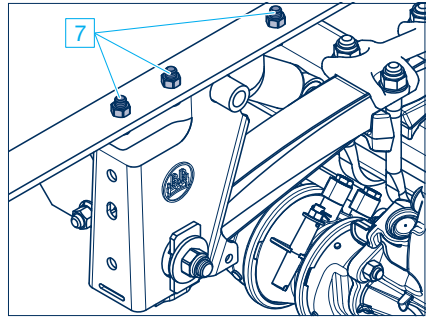

8 Bolted connection, gusset plate spring bolts

– Service intervals as shown on page 70 –

Check the mounting bolts of the gusset plates on the spring bolts are firmly tightened, and retighten with a torque wrench if necessary.

Tightening torque:

M 18 x 1.5 (SW 27) M = **420 Nm** (390 - 460 Nm)

Installing or renewing the spring bolt:

1. Unscrew or install the spring bolt.
2. Loosely pre-mount the gusset plate with at least three M 16 bolts at the top on the cross-member and one M 18 bolt at the bottom on the spring bolt and tighten further until contact is made.
3. Set the track.
4. Tighten the spring bolt to the prescribed tightening torque.
5. Tighten the connecting bolt on the gusset plates spring bolt and then tighten the upper connecting bolt to the prescribed tightening torques.

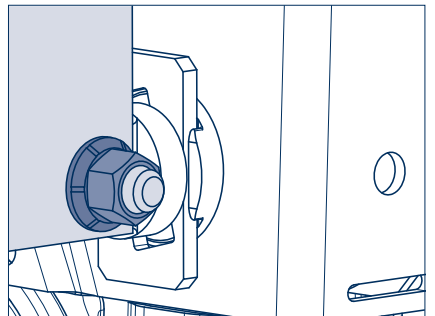
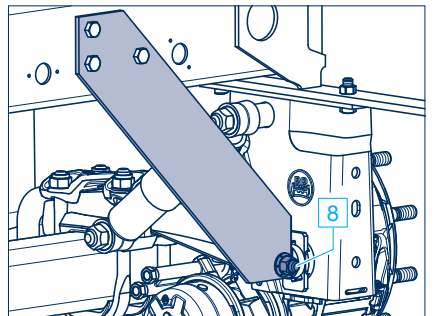

6 BPW Air suspension, series SL / AL

6.3 Maintenance Work and Visual Inspection

9 Axle lift

– Service intervals as shown on page 70 –

Single-sided lift

Check the M16 lock nuts on the lever arm fixing to make sure they are tight. Tighten with a torque wrench if necessary.

Tightening torque:

M 16 (SW 22) M = 230 Nm

Check for wear on the bump stop on the lever arm. Make sure it is secure.

Tightening torque:

M 10 (SW 17) M = 25 Nm

M 12 (SW 17) M = 66 Nm

Two-sided lift:

a) Check the M 16 lock nuts on the diaphragm cylinder to make sure they are tight. Tighten with a torque wrench if necessary.

Tightening torque:

M 20 (SW 30) M = 350 - 380 Nm

M 16 (SW 24) M = 180 - 210 Nm

b) Check the bump stop on the lever arm for wear, and that the M 6 attachment bolts are firmly tightened.

c) Check that the attachment bolts of the front bracing strut of the mount on the air suspension hanger bracket are tight, and in the case of the bolt-on two-sided lift, the bolted connection on the air suspension hanger bracket.

Tightening torque:

M 12 (SW 17) M = 75 Nm

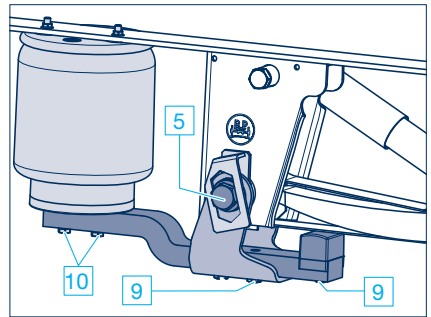

Single-sided lift

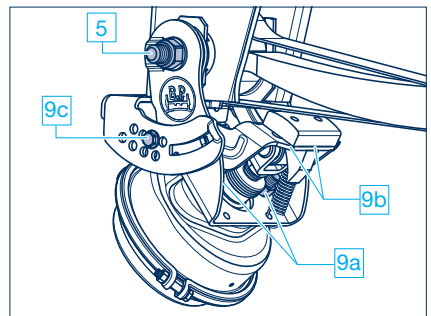

Two-sided lift

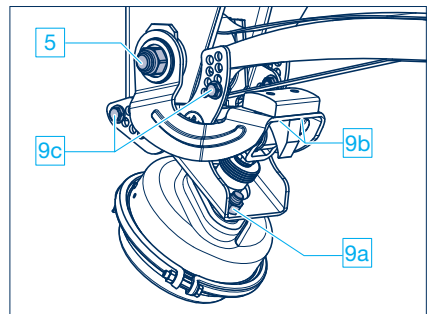

Bolt-on double-sided lift

Spring pivot bolt bearing with axle lift

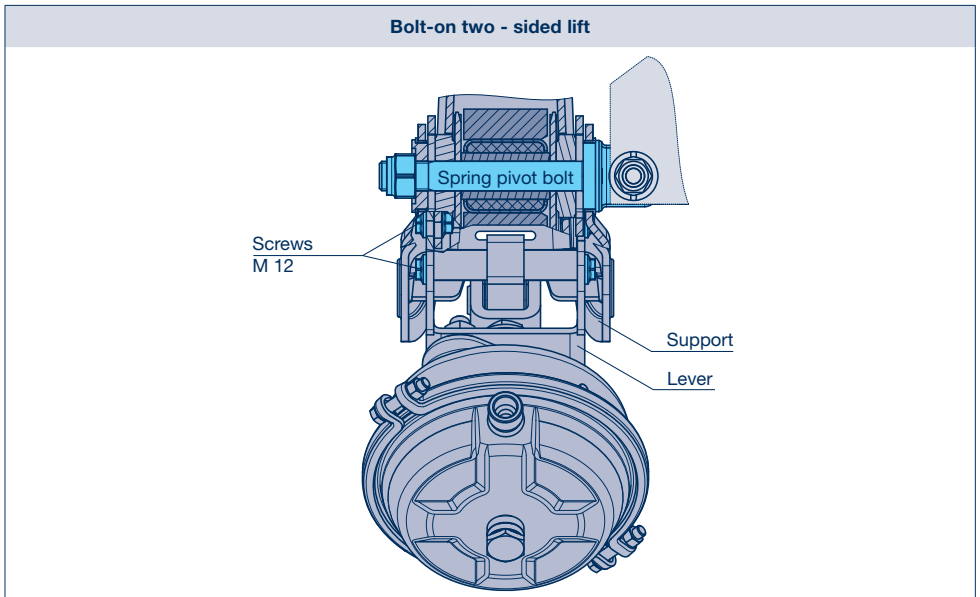
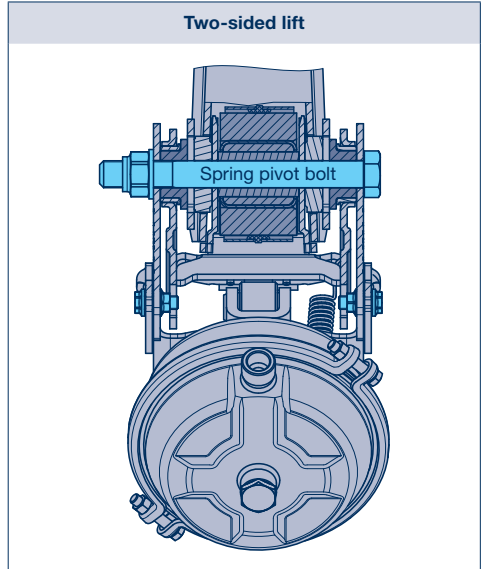
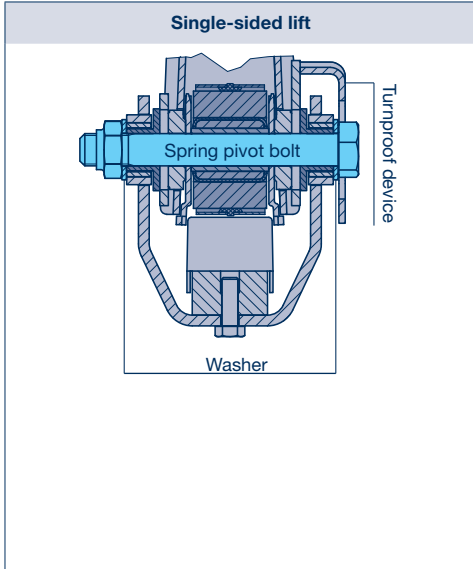

6 BPW Air suspension, series SL / AL

6.3 Maintenance Work and Visual Inspection

10 Air bag fastenings

– Service intervals as shown on page 70 –

Check air bag fixing bolts or nuts for tightness.
If necessary retighten using torque wrench.

Tightening torques with a torque wrench:

M 12 (SW 17)	M = 66 Nm
M 16 (SW 22)	M = 230 - 300 Nm

Lower attachment - centre screw
M 16 (SW 22) M = 300 Nm

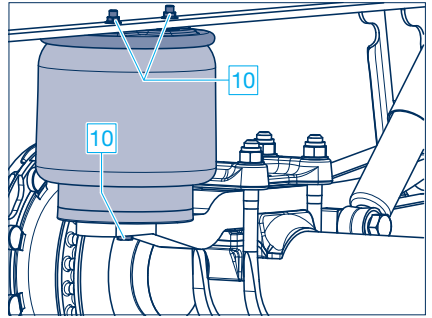

11 Stabilizer

– Service intervals as shown on page 70 –

Check stabilizer bearings for wear and tightness.

Tightening torques with a torque wrench:

M 10 (SW 17)	M = 53 Nm
M 30 (SW 46)	M = 750 Nm (700 - 825 Nm)

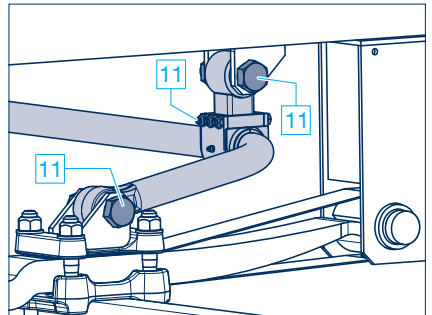

7 BPW Suspension, series ECO Cargo VB

7.1 Overview, Lubrication and Maintenance Work, Visual Inspection

Overview	Initially after 2 weeks	Every 6 weeks	Every 26 weeks (twice annually) ¹⁾
For detailed descriptions, see pages 84 - 87 For BPW trailer axles / steering axles, see pages 6 - 50			
① Grease bearings (suspension type E) with BPW special longlife grease ECO-Li ^{Plus} . (Not applicable in the case of rubber/steel bushes.)	<input type="radio"/> ¹⁾	<input type="radio"/> ¹⁾	
② Slightly grease the slide elements/slide ends of springs.	<input type="radio"/>	<input type="radio"/>	
1 Check threaded bolts on equaliser arm bearings for tightness. up to an axle load of 5.5 tonnes (from 03/2016) M 30 (SW 46) M = 725 Nm up to an axle load of 12 tonnes (from 08/2013) M 42 x 3 (SW 65) M = 1300 Nm up to an axle load of 12 tonnes (up to 07/ 2013) M 42 x 3 (SW 65) M = 1100 Nm Series HD / HDE M 48 x 3 (SW 65) M = 1200 - 1300 Nm			<input type="checkbox"/>
2 Check axle connecting rod bolts for tightness using a torque wrench. M 24 x 2 (SW 36) M = 650 Nm M 30 (SW 46) M = 725 Nm M 36 (SW 55) M = 1425 Nm	<input type="checkbox"/>		<input type="checkbox"/>
3 Check connecting rod clamping bolts for tightness. M 12 (SW 19) M = 66 Nm M 14 (SW 22) M = 140 Nm			<input type="checkbox"/>
4 Check spring U-bolts for tightness using a torque wrench. M 20 (SW 30) M = 315 - 375 Nm M 24 (SW 36) M = 600 - 650 Nm	<input type="checkbox"/>		<input type="checkbox"/>
- Visual inspection, check all component parts and welding seams for wear and damage.			<input type="checkbox"/>
5 Check spring pivot bolts for tightness. (Serie up to 5.5 t) M 20 (SW 30) M = 340 Nm	<input type="checkbox"/>		<input type="checkbox"/>
6 Check slide elements and rollers for tightness. M 14 (SW 22) M = 140 Nm M 16 (SW 24) M = 163 Nm M 20 (SW 30) M = 320 Nm			<input type="checkbox"/>

¹⁾ Under extreme conditions, with more frequency.

Note:

Components that have damage due to improper mounting are to be exchanged

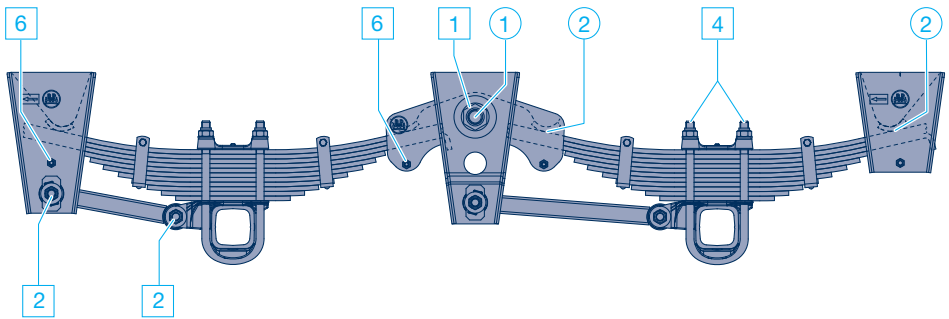

Series ECO Cargo VB ...M ...ME

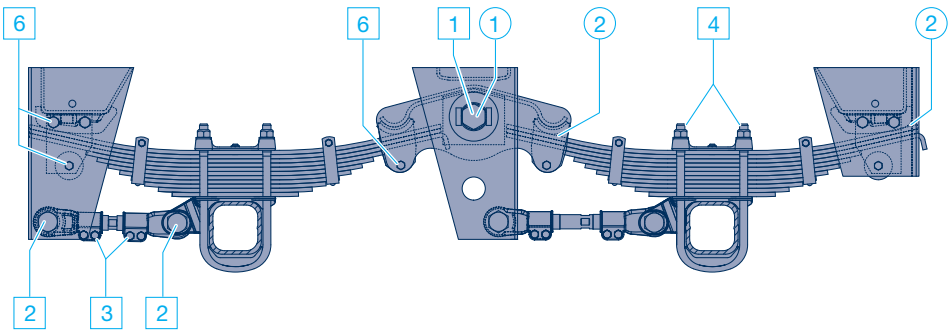

Series ECO Cargo VB HD / HDE

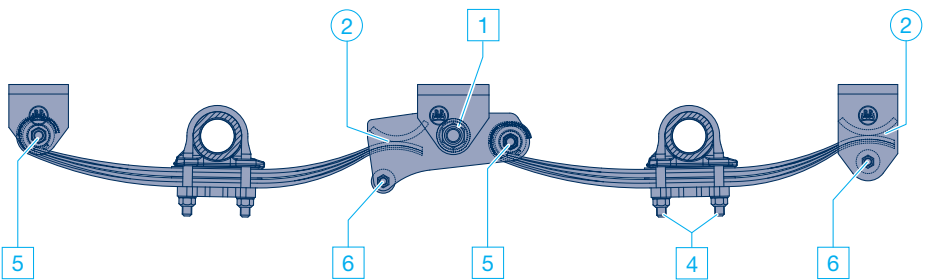

Series ECO Cargo VB 5,5 t

7 BPW Suspension, series ECO Cargo VB

7.2 Lubrication

- ① **Equalizer arm bearings** with bronze bushes (Series ECO Cargo VB ME and ECO Cargo VB HDE)
 – initially after 2 weeks then every 6 weeks –
 – under extreme conditions, lubricate with more frequency –

Lift trailer to take pressure off equalizer arm bearings.

Grease bronze bush bearing via the grease nipple in the heads of the threaded bolts with BPW special longlife grease ECO-Li^{plus} until fresh grease emerges. (Not applicable to rubber/steel bushes.)

At extremely low temperatures (-30° C to -50° C) a grease with correspondingly lower consistency class should be used - such as BPW ECO-Li Polar.

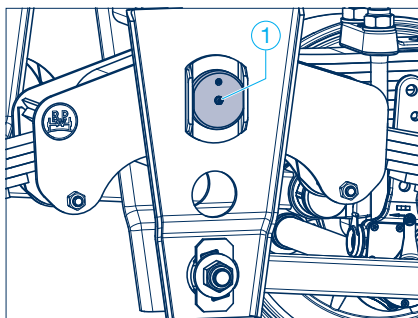

- ② **Slide elements**
 – initially after 2 weeks then every 6 weeks –
 – under extreme conditions, lubricate with more frequency –

Clean and lightly grease the slides / slide ends of the springs.

In the case of ECO Cargo VB suspensions (up to 07/2013) with anti-vibration leaf underneath the parabolic springs, grease the lower slide elements via the grease nipples (arrow).

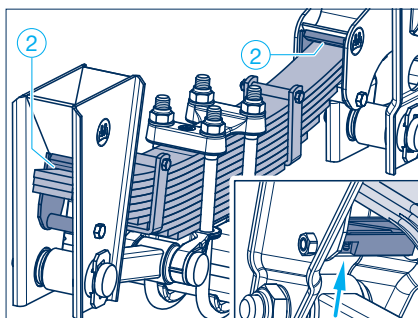

Maintenance Work and Visual Inspection 7.3

1 Equalizer arm bearings

– twice annually –

Check nuts on the equalizer arm bearings for tightness. The serviceable life of the rubber/steel bush bearings is dependent on the tightness of the inner steel bush.

Tightening torques:

up to an axle load of 5.5 tonnes (from 03/2016)

M 30 (SW 46) M = 725 Nm

up to an axle load of 12 tonnes (from 08/2013)

M 42 x 3 (SW 65) M = 1300 Nm

up to an axle load of 12 tonnes (up to 07/2013)

M 42 x 3 (SW 65) M = 1100 Nm

Series HD / HDE

M 48 x 3 (SW 65) M = 1200 - 1300 Nm

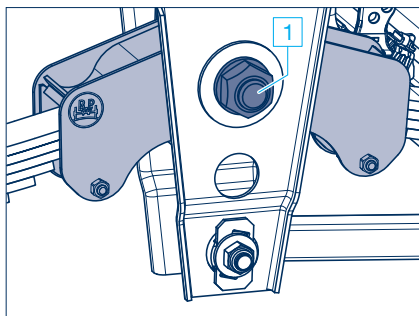

2 Axle guide linkages

– twice annually, initially after 2 weeks –

Check lock nuts of the axle guide linkages/connecting rods for tightness using a torque wrench.

Tightening torques:

M 24 x 2 (SW 36) M = 650 Nm

M 30 (SW 46) M = 725 Nm

M 36 (SW 65) M = 1425 Nm

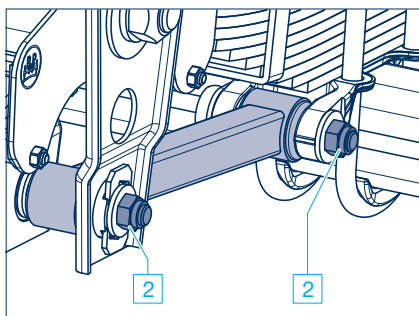

3 Connecting rods (only at series VB up to manufacturing year 08.2013 and ECO Cargo VB HD)

– twice annually –

Check connecting rod clamping screws for tightness.

Tightening torques:

M 12 (SW 19) M = 66 Nm

M 14 (SW 22) M = 140 Nm

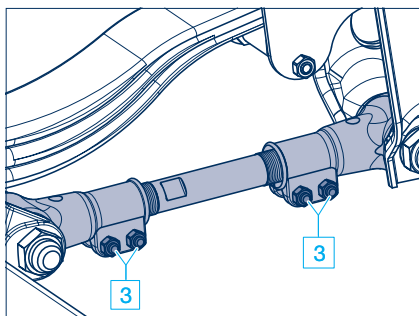

7 BPW Suspension, series ECO Cargo VB

7.3 Maintenance Work and Visual Inspection

- 4 Spring U-bolts**
– initially after 2 weeks then twice annually –

Check spring U-bolts for tightness. If necessary loosen lock nuts, tighten nuts alternately to the prescribed torque, and a bit at a time, if necessary then re-lock.

Tightening torques:

M 20 (SW 30)	M = 315 - 375 Nm
M 24 (SW 36)	M = 600 - 650 Nm

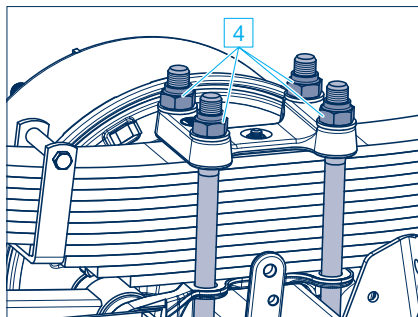

- Visual inspection**
– twice annually –

Check all component parts and welding seams for wear and damage.

In order to check the bearing on the equalizer and axle guide linkage, move the vehicle back and forth slightly with the brake applied; or move the bearing points with the aid of a lever. No play should be present in the bearing when doing so.

- 5 Spring pivot bolts** (serie ECO Cargo VB up to 5.5 t)
– initially after 2 weeks then twice annually –

Check bushes; move vehicle back and forth slightly with brakes applied or move spring eyes with assembly lever with brakes released. No play should be present in the rolled spring end when doing so. If the fastening is loose the spring pivot bolt may be damaged.

Check the M 20 lock nut on the spring pivot bolt for tightness.

Tightening torque with a torque wrench:
M 20 (SW 30) M = 340 Nm

The life expectancy of the bearing depends on the tightness of the spring bolt or the inner bush.

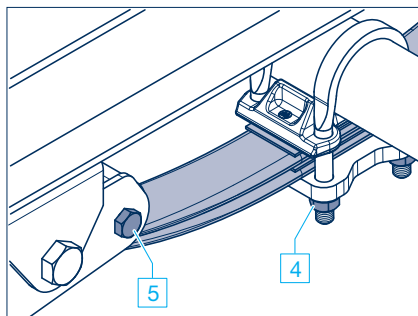

6 Slide elements
– twice annually –

Check slide elements and lateral wear plates in the shackle and equalizer arm for wear and the fastening screws for tightness.

Tightening torques:

M 14 (SW 22)	M = 140 Nm
M 16 (SW 24)	M = 163 Nm
M 20 (SW 30)	M = 320 Nm

If necessary, check rubber rollers under the spring ends for wear.

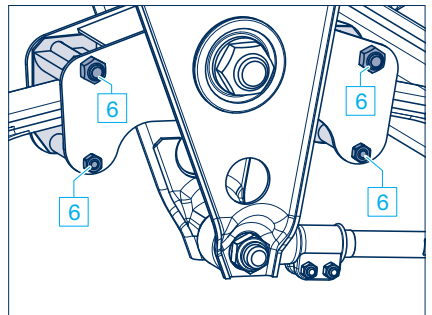
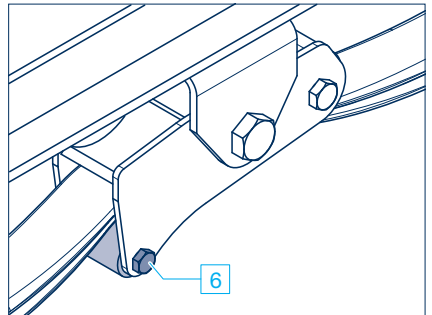
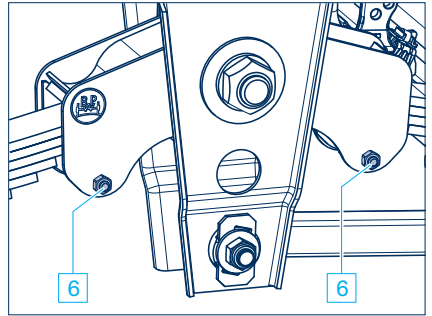

8 BPW Suspension, series ECO Cargo W / BW / GW

8.1 Overview, Lubrication and Maintenance Work, Visual Inspection

Overview	Initially after 2 weeks	Every 6 weeks	Every 26 weeks (twice annually) ¹⁾
For detailed description, see pages 90 - 91 BPW trailer axles / steering axles, see pages 6 - 50			
<input checked="" type="checkbox"/> Grease axle support bearing series W, BW using BPW special longlife grease ECO-Li ^{Plus} .	<input checked="" type="radio"/> ¹⁾	<input checked="" type="radio"/> ¹⁾	
<input checked="" type="checkbox"/> Grease spring housing series W using BPW special longlife grease ECO-Li ^{Plus} .	<input type="radio"/>	<input type="radio"/>	
<input type="checkbox"/> Visual inspection, check all component parts and welding seams for wear and damage.			<input type="checkbox"/>
<input checked="" type="checkbox"/> Check spring U-bolt of support axle for tightness. M 30 x 2 (SW 46) M = 980 Nm M 36 (SW 55) M = 1555 Nm	<input type="checkbox"/>		<input type="checkbox"/>
<input checked="" type="checkbox"/> Check fastening screws on the bearing covers for tightness. M 20 (SW 30) M = 320 Nm M 24 (SW 36) M = 570 Nm	<input type="checkbox"/>		<input type="checkbox"/>
<input checked="" type="checkbox"/> Check spring U-bolts on the spring housing for tightness. M 20 (SW 30) M = 450 Nm M 24 (SW 36) M = 700 Nm	<input type="checkbox"/>		<input type="checkbox"/>

¹⁾ Under extreme conditions, with more frequency.

Note:

Components that have damage due to improper mounting are to be exchanged

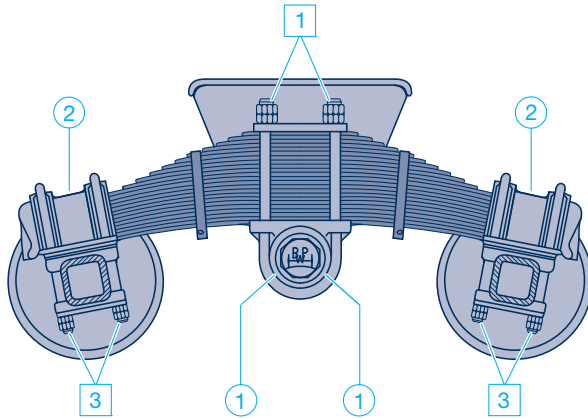

Series ECO Cargo W

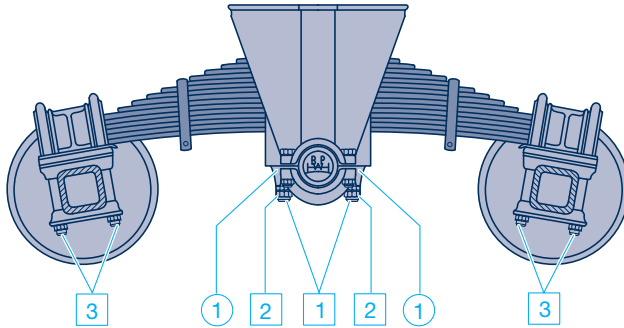

Series ECO Cargo BW / GW

8 BPW Suspension, series ECO Cargo W / BW / GW

8.2 Lubrication

① Support axle (series W, BW)

- initially after 2 weeks then every 6 weeks -
- under extreme conditions, lubricate with more frequency -

Lift trailer to take pressure off the trunnion bearings. Grease lubrication nipple front and rear on the bearing brackets of the support axle using BPW special longlife grease ECO-Li^{plus} until fresh grease emerges (not applicable to axle assembly series GW = rubber bush).

At extremely low temperatures (-30° C up to 50° C) a grease with correspondingly lower consistency class should be used - such as BPW ECO-Li Polar.

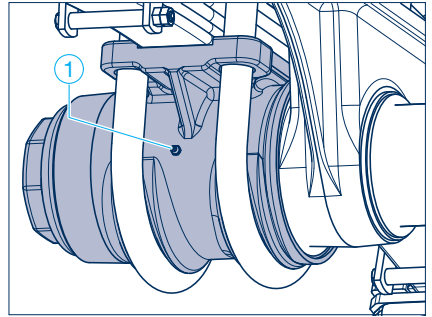

Series ECO Cargo W

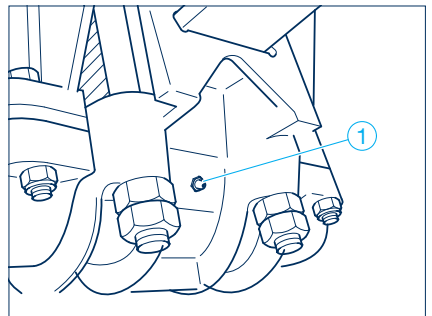

Series ECO Cargo BW

② Spring housing (series W)

- initially after 2 weeks then every 6 weeks -

Grease lubrication nipples on the spring housing using BPW special longlife grease ECO-Li^{plus}.

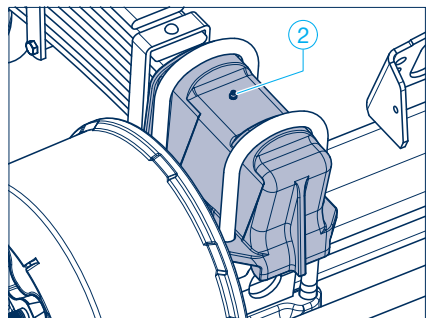

Series ECO Cargo W

Maintenance Work and Visual Inspection 8.3

- Visual inspection – twice annually –

Check all components and welding seams for wear and damage.

1 Spring U-bolts on the trunnion axle – twice annually, initially after 2 weeks –

Check spring U-bolts for tightness.
If necessary loosen lock nuts, tighten nuts alternately to the prescribed torque, a bit at a time, then relock.

Tightening torques:

M 30 x 2 (SW 46)	M = 980 Nm
M 36 (SW 55)	M = 1555 Nm

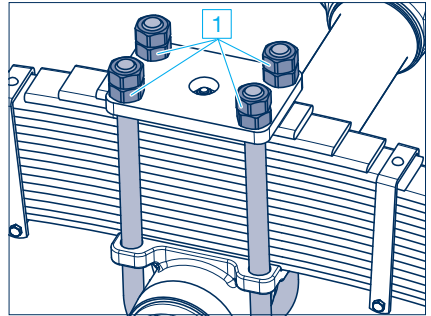

2 Fastening screws on the cover plates – twice annually –

Check the fastening screws on the cover plates of the support axle for tightness.

Tightening torques:

M 20 (SW 30)	M = 320 Nm
M 24 (SW 36)	M = 570 Nm

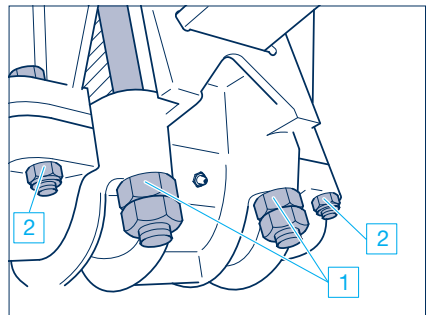

3 Spring U-bolts on the spring housings – twice annually, initially after 2 weeks –

Check spring U-bolts on the spring housings for tightness. If necessary loosen lock nuts, tighten nuts alternately to the prescribed torque, a bit at a time, if necessary then relock.

Tightening torques:

M 20 (SW 30)	M = 450 Nm
M 24 (SW 36)	M = 700 Nm

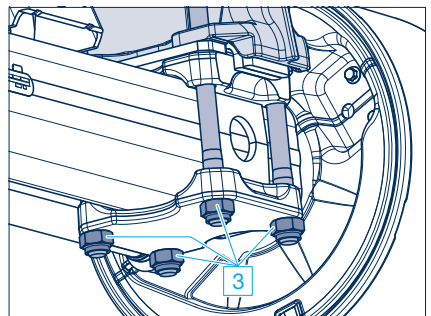

BPW is a globally leading manufacturer of intelligent running gear systems for trailers and semi-trailers. As an international mobility and system partner, we offer a wide range of solutions for the transport industry from a single source, from axle to suspension and brake to user-friendly telematics applications.

We thereby ensure outstanding transparency in loading and transport processes and facilitate efficient fleet management. Today, the well-established brand represents an international corporation with a wide product and service portfolio for the commercial vehicle industry. Offering running gear systems, telematics, lighting systems, composite solutions and trailer superstructures, BPW is the right system partner for automotive manufacturers.

BPW, the owner-operated company, consistently pursues one target: To always give you exactly the solution which will pay off. To this end, we focus our attention on uncompromising quality for high reliability and service life, weight and time-saving concepts for low operating and maintenance costs as well as personal customer service and a close-knit service network for quick and direct support. You can be sure that with your international mobility partner BPW, you always use the most efficient method.

Your partner on the path to economic viability



BPW Axles (Pty) Ltd · PO Box 82545 · Southdale 2135 · Johannesburg
Tel (011) 681-3300 · (011) 680-1443 · Fax (011) 680-1829
bpwsales@bpw.co.za · www.bpw.co.za