

H
K
N

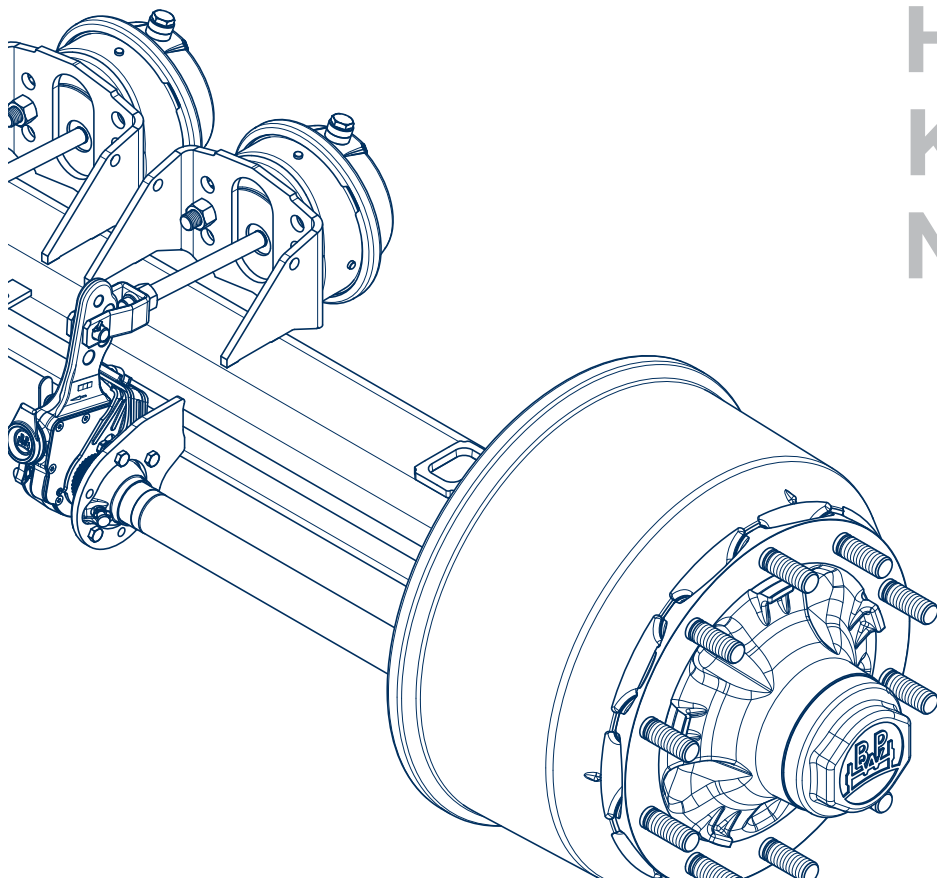

Workshop manual

BPW trailer axles with drum brakes



BPW trailer axles with drum brake

S-camshaft SN 420 / SN 360 / SN 300

ECO Plus 3, ECO Plus 2, ECO^{Plus}, ECO and conventional wheel hub bearing

Valid: 01.05.2016

Subject to change without notice.

Current versions and additional information can be found online at www.bpw.de.

Contents

◎ 1. Product identification	Page 4
1.1 BPW Type plate - Axle	Page 4
1.2 Explanation of BPW axle type codes	Page 5
1.3 Explanation of BPW axle code numbers	Page 6
◎ 2. Exploded view / name	Page 9
◎ 3. Safety regulations, safety information	Page 14
3.1 Safety regulations	Page 14
3.2 Safety information	Page 15
◎ 4. Tightening torques	Page 16
◎ 5. Special tools	Page 17
◎ 6. Lubrication and maintenance work	Page 22
◎ 7. Changing the brake lining	Page 48
7.1 Removal of the wheel hub brake drum unit	Page 48
7.2 Changing the brake lining	Page 51
7.3 Riveting check	Page 55
7.4 Brake shoe installation	Page 56
7.5 Installation of the brake shoes	Page 58
7.6 Installation of the wheel hub brake drum unit	Page 61
7.7 Conversion to brake with split roller (BPW 95 Brake)	Page 71
◎ 8. Dismantling and assembling the hub unit	Page 72
8.1 ECO Plus 3 Unit	Page 72
8.2 ECO Plus 2 Unit	Page 80
8.3 ECO ^{Plus} Unit	Page 89
8.4 ECO Unit	Page 101
8.5 Conventional wheel hub bearing	Page 108
◎ 9. ABS / ABV	Page 111
◎ 10. Brake back plates for Brake - ECO Drum	Page 113
◎ 11. Brake camshaft	Page 115
◎ 12. Manual slack adjuster GSK	Page 121
◎ 13. Automatic slack adjuster ECO-Master	Page 122
◎ 14. Brake wear sensing	Page 124
14.1 Function	Page 124
14.2 Installation instructions	Page 125
◎ 15. Brake cylinder	Page 127
15.1 Maintenance	Page 127
15.2 Preparations for assembly	Page 127
15.3 Installation diaphragm cylinder	Page 127
15.4 Installation spring brake cylinder	Page 129
◎ 16. Digital ECOMETER	Page 130
16.1 Function	Page 130
16.2 Startup and setting the tyre rolling circumference	Page 131
16.3 Installation	Page 133
16.4 Battery	Page 134
16.5 Conversion	Page 135

1 Product identification

1.1 BPW-Type plate - Axle

Riveted type plate up to year of manufacture 1999

Axle type BPW code number Date and serial number

Brake type

Certificate type Test report no. Stat. = Max. static axle load on ground
Tech. = "Permissible techn. axle load" = Test load of wheel brakes

Adhesive type plate from year of manufacture 2000

Type plate from year of manufacture 2006 (adhesive type plate) with barcode

Type plate from year of manufacture 2011 (adhesive type plate) with ECE certificate

- ID1 - Axle code
 - ID2 - Brake code
 - ID3 - Tested brake axle load
 - ID4 - Basic number of the test report
- ECE certificate

1.2 Explanation of BPW axle type codes (extract)

Example:												
H	S	F	A	H	9010	-15	ECO	Axle series	Axle beam	Brake	Tyre	
H								H..	☐			
R								R..	○	SN 420	20" - 24"	
KH								KH..	☐	SN 360	19.5"	
KM								KM..	■			
KR								KR..	○			
KRD								KRD	●			
NH								NH..	☐	SN 300	15" / 17.5"	
NR								NR..	○			
NRD								NRD..	●			
B								For single wheels, wheels with offset				
S								For single wheels, wheels without offset				
Z								For twin wheels				
I								Wheel spiders for TRILEX wheel rims, single wheels				
IZ								Wheel spiders for TRILEX wheel rims, twin wheels				
F								Wheel studs M 22 x 1.5 without wheel nuts, order wheel nuts for stud or spigot alignment separately				
M								For spigot alignment				
A								With alloy hubs				
H								For hanging boosters				
						6006 to 20010		Axle load (kg) + quantity of wheel studs per hub				
							-15	Axle beam - wall thickness, e.g. 15 mm				
							-1	Type of hub bearing (e.g. 14 t)				
							/3	Wheel connection - 10 wheel studs, pitch circle 335 mm				
								ECO Plus 3	Weight optimised trailer axle with ECO Plus 3 Unit			
								ECO Plus 2	Weight optimised trailer axle with ECO Plus 2 Unit			
								ECO ^{Plus}	Weight optimised trailer axle with ECO ^{Plus} Unit			
								ECO-MAXX	Weight optimised trailer axle with ECO Unit			
								ECO	Trailer axle with ECO Unit			
								MAXX	Weight optimised trailer axle with helical fit wheel bolts			

1 Product identification

1.2 Explanation of BPW axle code numbers (extract)

Example:				
30.	38.	743.	000	
Axle type				
20.				
21.				
22.				
24.				
25.			Trailer axle without suspension parts	
27.				
29.				
30.				
31.				
		Axle load	Roller bearing	Bearing generation
06.		6500 kg	33116 / 32310	Conventional hub bearing
08.		8000 - 9000 kg	33116 / 32310	
09.		8000 - 9000 kg	33116 / 32310	
10.		10000 - 12000 kg	33118 / 32313	
14.		13000 - 14000 kg	32219 / 33215	
16.		16000 - 18000 kg	32222 / 33214	
20.		20000 kg	32224 / 32316	
36.		6500 kg	33116 / 32310	ECO Unit
38.		8000 - 9000 kg	33116 / 32310	
40.		10000 - 12000 kg	33118 / 32313	
44.		13000 - 14000 kg	32219 / 33215	
48.		8000 - 9000 kg	33118 / 33213	ECO ^{Plus} Unit
50.		10000 - 12000 kg	33118 / 33213	
56.		6500 kg	33118 / 33213	ECO Plus 2 Unit
57.		8000 - 9000 kg	33118 / 33213	
58.		8000 - 9000 kg	33118 / 33213	
59.		8000 - 9000 kg	33118 / 33213	
65.		6400 kg	33215 / 32310	Conventional hub bearing
66.		6500 kg	33118 / 33213	ECO Plus 3 Unit
68.		8000 - 9000 kg	33118 / 33213	

Example:			
30.	38.	743.	000
		Wheel brake type	Dimension
10.		SN 3015 BPW 95 closed	Ø 300 x 150
11.		SN 3020 BPW 95 closed	Ø 300 x 200
20.		SN 3620 BPW 95 closed	Ø 360 x 200
30.		SN 4212 BPW 95 closed	Ø 420 x 120
31.		SN 4218 BPW 95 closed	Ø 420 x 180
32.		SN 4220 BPW 95 closed	Ø 420 x 200
592.		SN 3015 HWG closed	Ø 300 x 150
596.		SN 3020 HWG closed	Ø 300 x 200
501.		SN 3015 BPW 95 closed	Ø 300 x 150
502.		SN 3020 BPW 95 closed	Ø 300 x 200
505.		SN 3015 BPW 95 closed	Ø 300 x 150
542.		SN 3616 closed	Ø 360 x 160
546.		SN 3620 closed	Ø 360 x 200
551.		SN 3616 BPW 95 closed	Ø 360 x 160
552.		SN 3620 BPW 95 closed	Ø 360 x 200
790.		SN 4212-2 HWG open	Ø 420 x 120
794.		SN 4212-2 HWG closed	Ø 420 x 120
710.		SN 4218-2 HWG open	Ø 420 x 180
714.		SN 4218-2 HWG closed	Ø 420 x 180
718.		SN 4220-2 HWG open	Ø 420 x 200
723.		SN 4220-2 HWG closed	Ø 420 x 200
739.		SN 4222-2 HWG closed	Ø 420 x 220
741.		SN 4212 BPW 95 closed	Ø 420 x 120
743.		SN 4218 BPW 95 closed	Ø 420 x 180
744.		SN 4220 BPW 95 closed	Ø 420 x 200
745.		SN 4222 BPW 95 closed	Ø 420 x 220
		000	Consecutive number 000 - 999

ECO-Master

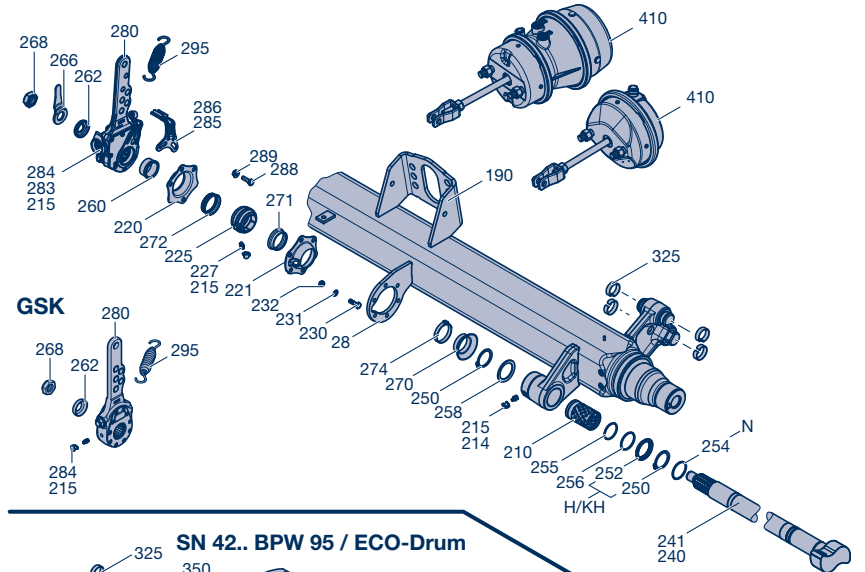

GSK

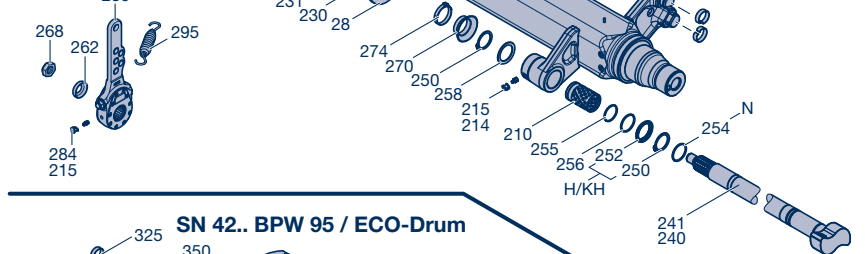

SN 42.. BPW 95 / ECO-Drum

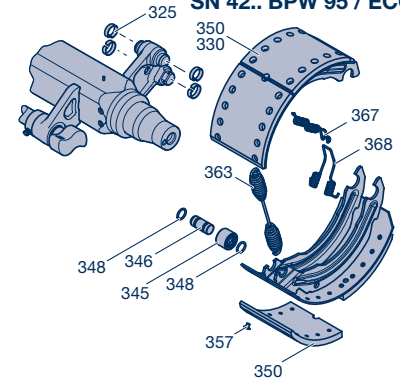

SN 3620 BPW 95 SN 30.. BPW 95

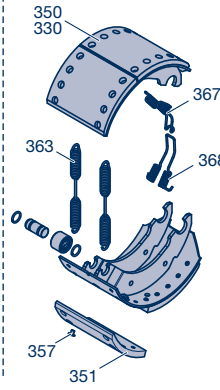

SN 3616 BPW 95

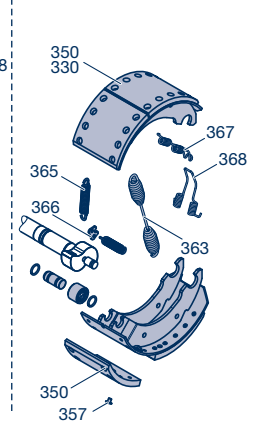

2 Exploded view

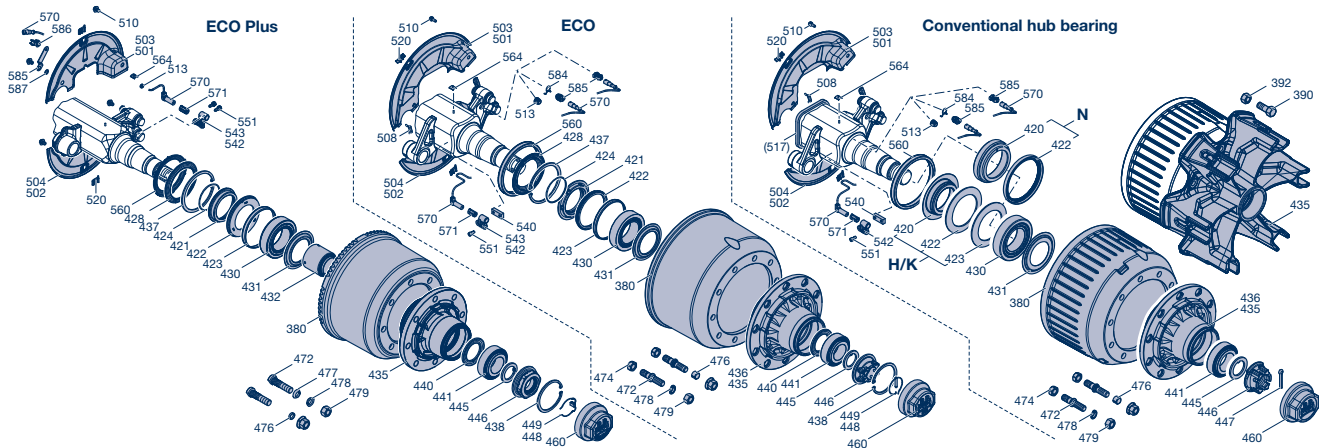
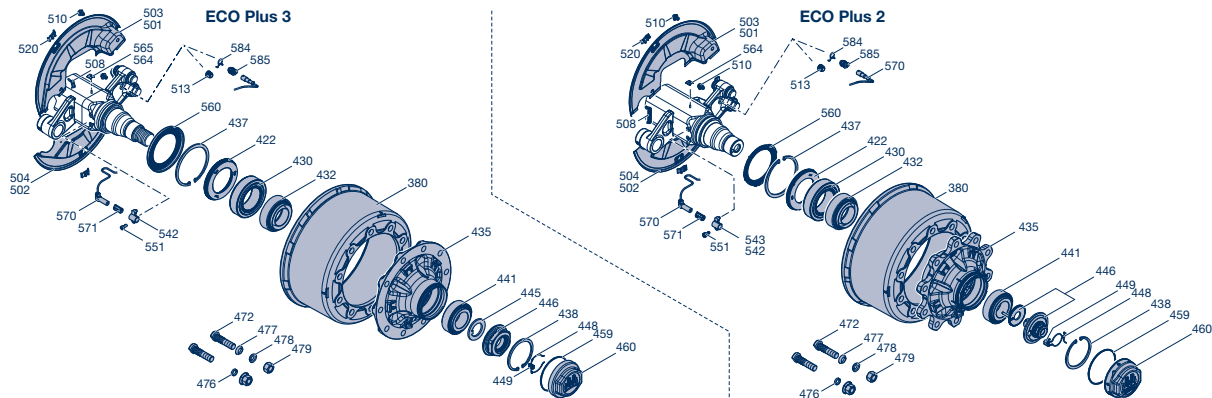

2 Name

Item	Name
28	Support bearing plate
190	Booster bracket
410	Brake cylinder

Brake camshaft bearing

Item	Name
210	Bush
214	Grease nipple
215	Cover
220	Bearing box
221	Bearing box, for grease nipple
225	Spherical bearing
227	Grease nipple
230	Hexagon screw
231	Spring washer
232	Hexagon nut / Lock nut
240	Brake camshaft, left
241	Brake camshaft, right
250	Locking ring
252	Ring
254	Ring
255	O-ring (black)
256	O-ring (green)
258	Sealing ring
260	Bush
260	Locking ring
262	Washer
266	Brake lining wear indicator
268	Lock nut
270	Sealing ring
271	Sealing ring
272	Sealing ring
274	Circlip

Slack adjuster

Item	Name
280	Slack adjuster
283	Cap
284	Grease nipple
285	Shaped plate
286	Shaped plate
288	Hexagon screw
289	Lock nut
295	Return spring

Brake shoes

Item	Name
325	,C' Clip
330	Brake shoe with lining
345	Roller
346	Bolt
348	Ring
350	Brake lining (10 rivets)
351	Brake lining (8 rivets)
357	Rivet
363	Return spring
365	Return spring (SN 3616)
366	Plate (SN 3616)
367	Return spring (hook)
368	Return spring (eye)

Wheel hub bearing

ECO Plus 3

Item	Name
380	Brake drum ECO Drum
422	Oil seal
430	Roller bearing
432	Seal / Grease cartridge
435	Hub
437	Locking ring
438	Locking ring
441	Roller bearing
445	Washer
446	Axle nut
448	Hooked spring ring
449	Locking piece
459	O-ring
460	Hub cap

ECO Plus 2

Item	Name
380	Brake drum ECO Drum
422	Oil seal (ECO Seal)
430	Roller bearing
432	Grease cartridge
435	Hub
437	Locking ring
438	Locking ring
441	Roller bearing
446	Axle bolt with toothed washer
448	Hooked spring ring
449	Locking piece
459	O-ring
460	Hub cap (bayonet)

ECO^{Plus}

Item	Name
380	Brake drum ECO Drum
421	Thrust washer
422	Oil seal (ECO Seal)
423	Ring (bearing race)
424	O-ring
428	Dirt seal
430	Roller bearing
431	Dust cover (oil catcher)
432	Seal
435	Hub
437	Locking ring
438	Locking ring
440	Trust cover
441	Roller bearing
445	Washer
446	Axle nut
448	Hooked spring ring
449	Locking piece
460	Hub cap

ECO

Item	Name
380	Brake drum ECO Drum
421	Thrust washer
422	Oil seal
423	Ring
424	O-ring
428	Dirt seal
430	Roller bearing
431	Dust cover (oil catcher)
435	Hub
436	Splined pin
437	Locking ring
438	Locking ring
440	Trust cover
441	Roller bearing
445	Washer
446	Axle nut
448	Hooked spring ring
449	Boit
460	Hub cap

Conventional hub bearing.

Item	Name
380	Brake drum ECO Drum
390	Trilex screw
392	Lock nut Trilex
420	Thrust washer
422	Oil seal (Series N)
422	Ring (Nylon)

423	Ring (Nylon)
430	Roller bearing
431	Dust cover (oil catcher)
435	Hub
435	Trilex wheel
436	Splined pin
441	Roller bearing
445	Washer
446	Axle nut
447	Split pin
460	Hub cap

Wheel attachment

Item	Name
472	Wheel stud
474	Lock nut
476	Bush
477	Centering ring
478	Spring washer
479	Wheel nutr

Dust cover

Item	Name
501	Dust cover, left upper
502	Dust cover, left lower
503	Dust cover, right upper
504	Dust cover, right lower
508	Return spring for dust cover
510	Collar screw
513	Cable grommet
517	Seal
520	Plug

ABS

Item	Name
540	Block (Sensor bracket)
542	Sensor bracket
543	Sensor bracket
551	Locking screw
560	Exciter ring
564	Clamp
570	Sensor
571	Bush for ABS
584	Hooked spring ring
585	Retaining clip
586	Retaining clip
587	Serrated lock washer

3 Safety regulations, safety information

3.1 Safety regulations

- All work must be performed by trained mechanics at competent repair facilities or authorised specialist companies who have access to all relevant tools and have acquired the know-how required for this work. Anyone who performs maintenance and repair work must be trained in automotive mechanics and already have experience in repairing trailers. Anyone who performs brake work must be trained in brake systems.
- Comply with local safety regulations.
- The relevant operation and service regulations as well as safety regulations of the vehicle manufacturer and of the manufacturers of other vehicle parts must be adhered to.
- The dust created from grinding brake pads comprises particulate matter that can cause lung damage. A safety mask must therefore be worn to prevent brake dust from being inhaled.
- Use prescribed dust washing devices or vacuum cleaners for cleaning, never use compressed air or other high-pressure devices.
- Ensure adequate ventilation at the workplace.
- The vehicle must be prevented from moving during repair work. Please observe the relevant safety regulations for repair work on commercial vehicles, in particular the safety regulations for jacking up and securing the vehicle.
- During repair work, make sure that the brake is not operated inadvertently.
- Do not perform repair work unless wearing protective clothing (gloves, safety boots, safety goggles, etc.) and using the recommended tools.
- Work on brake components removed from the vehicle must be carried out with the components fixed in place such as in a vice.
- Only use recommended tools.
- A second mechanic must provide assistance when working with heavy components (brake drums or brake removal/installation).
- All air lines and components must be depressurised before being removed.
- Following each repair, perform a function check or a test drive in order to make sure that the brakes are functioning correctly. New drums and pads only have maximum effect after a few braking actions. Avoid hard braking.
- All exchanged components must be reused or disposed of in accordance with the applicable environmental regulations, laws and directives.
- The remaining thickness of the brake lining (see page 36) and the condition of the brake drum (see page 37) must be visually inspected at regular intervals with respect to the way in which the vehicle is used.
- Tighten screws and nuts with the prescribed tightening torque.

Safety information 3.2

This workshop manual contains different types of safety instructions, each of which is designated an icon and a signal word. The signal word describes the severity of the potential danger.



Danger!
Warning!
Caution!

Immediate potential danger of serious or fatal injury (severe injury or death).
Possible potential danger of serious or fatal injury (severe injury or death).
Possible dangerous situation (slight injury or damage to property).



Repair Guide!

Risk of damage to property or consequential damage if this information is not observed.



Note!

Application hints and especially useful information.



Mandatory!

Do not use an impact wrench; doing so would cause considerable damage!

It is essential that all maintenance work is carried out in accordance with the prescribed intervals in order to maintain the safe operation and roadworthiness of the trailer. The relevant operation and service regulations of the vehicle manufacturer and of the manufacturers of other vehicle parts must also be adhered to. Rectification of any defects which are discovered or replacement of worn parts should be carried out by a BPW Service Centre or BPW Direct Service Partner unless the vehicle owner has the facilities, equipment and workshop manuals and possesses an official certificate to perform interim inspections or special brake inspections.

When installing spare parts, it is strongly recommended that only original BPW components are used. Parts approved by BPW for trailer axles and suspensions regularly undergo special test procedures. BPW accepts product responsibility for them.

However, BPW cannot assess every single third-party product as to whether it can be used for BPW trailer axles and suspensions without any risk to safety. This applies even if such products have already been tested by an accredited test authority.

The warranty becomes null and void if spare parts other than original BPW parts are used.

4 Tightening torques

Item	Description	Thread / Spanner size	Tightening torque
460	Hub caps According to stamped tightening torque on face of cap BPW form: Steel caps for ECO Plus 3 hub BPW form: Steel caps for ECO Plus 2 hub BPW form: Steel caps for ECO ^{Plus} hub 8 - 12 t BPW form: Steel caps for ECO hub 6.5 - 14 t BPW form: Steel caps for conventional hub bearing 6.5 - 9 t BPW form: Alloy caps 10 - 12 t BPW form: Alloy caps 13 - 14 t BPW form: Alloy caps 16 - 18 t Octagon: Steel caps 6 - 12 t Octagon: Steel caps 13 - 20 t	SW 110 bayonet lock SW 110 SW 110 / SW 120 SW 95 SW 110 SW 120 SW 140 SW 110 SW 120	M = 350 Nm see page 29 M = 800 Nm M = 800 Nm M = 500 Nm M = 500 Nm M = 800 Nm M = 350 Nm M = 350 Nm M = 700 Nm
474	Locking nuts of wheel studs (brake drum side)	M 20 x 1.5 / SW 30 M 22 x 2 / SW 32	M = 300 Nm (280 - 330 Nm) M = 400 Nm (370 - 440 Nm)
409	Locking nuts on hexagon bolts (Trilex wheels)	M 20 - 8.8 / SW 27 M 20 - 10.9 / SW 27	M = 335 Nm (320 - 350 Nm) M = 450 Nm (430 - 470 Nm)
446	Axle nut / axle bolt		see pages 25, 28, 31, 32, 34
479	Wheel nuts		see page 36
410, 411	Attachment nuts for brake cylinder Compressed air connections on brake cylinder Spring „hold off” bolt on spring brake cylinder	M 16 x 1.5 / SW 24 M 16 x 1.5 / SW 24	M = 180 Nm (180 - 210 Nm) M = 45 Nm M = 40 Nm (30 - 50 Nm)
268	Locking nut for slack adjuster	M 22 x 1.5 / SW 32	M = 120 Nm
510	Locking bolt on cover plates	M 10 / SW 13	M = 43 Nm
551	Self-cutting bolt for sensor holder	M 8 / SW 13	M = 25 Nm
232, 289	Locking nut on bearing box Hexagon nut on bearing box	M 8 / SW 13 M 8 / SW 13	M = 28 Nm M = 23 Nm

Special tools 5

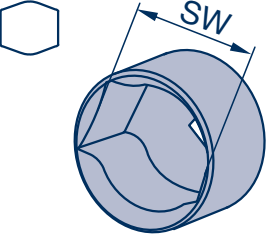
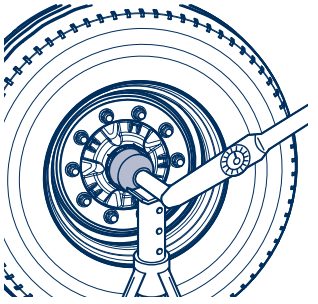
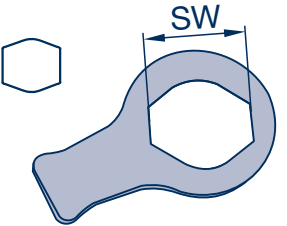
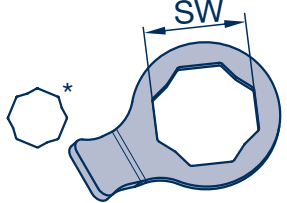
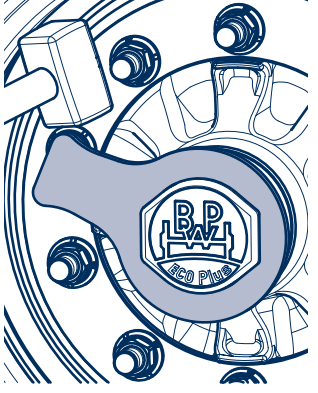
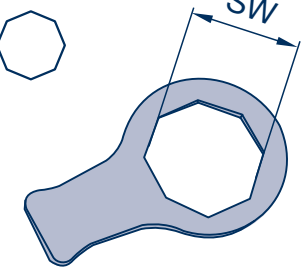
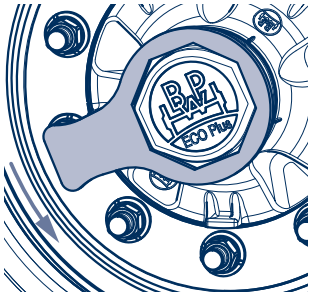
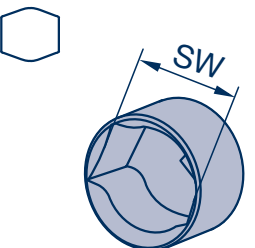
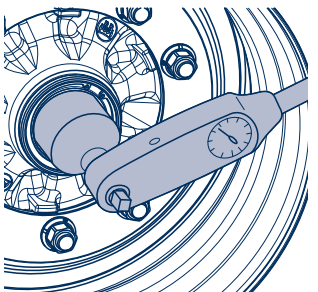
Number	Description	Illustration of tool	Tool in operation
1	Sockets for hub caps (BPW shape) BPW code number: 03.364.29.02.0 SW 95 03.364.29.03.0 SW 110 03.364.29.05.0 SW 140 ECO Plus 3 ECO		
2	Ring spanner for hub caps (flat shape / BPW shape) BPW code number: 03.339.04.03.0 SW 95 03.339.05.09.0 SW 140 03.339.05.04.0 SW 110 03.339.05.08.0* 03.339.05.02.0* SW 120 ECO Plus 3 / ECO ^{Plus} ECO Plus 2 * bent at right angle	 	
3	Ring spanner for hub caps (flat shape / octagonal) BPW code number: 03.339.05.07.0 SW 120 03.339.05.03.0 SW 130		
4	Sockets for axle nuts (BPW shape) BPW code number: 03.364.20.03.0 SW 65 03.364.24.03.0 SW 80		

5 Special tools

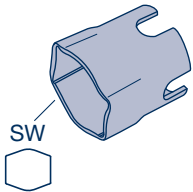
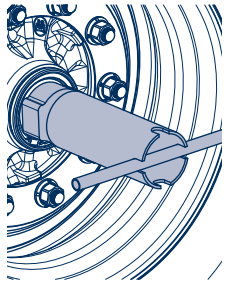
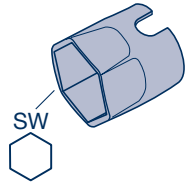
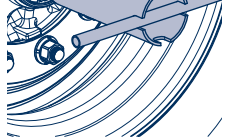
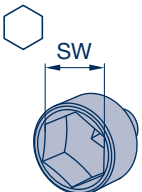
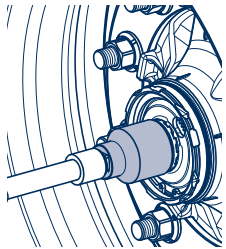
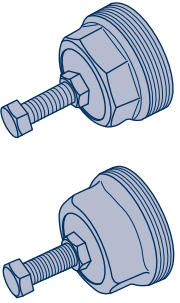
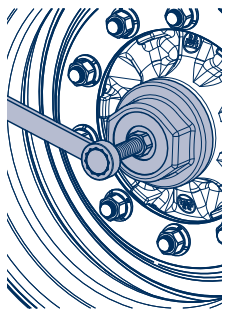
Number	Description	Illustration of tool	Tool in operation
5	Sockets for axle nuts BPW code number: 03.364.20.02.0 SW 65 03.364.24.02.0 SW 80 03.364.25.03.0 SW 85		
6	Sockets for axle nuts BPW code number: 03.364.25.01.0 SW 85 05.364.26.05.0 SW 95 ECO Plus 3 / ECOPlus 03.364.26.02.0 SW 100		
7	Sockets for axle nuts BPW code number: 03.364.18.02.0 SW 46 (ECO Plus 2)		
8	Hub puller BPW code number: 05.012.26.03.0 SW 95 M 115 x 2 05.012.27.05.0 SW 110 M 125 x 2 05.012.28.03.0 SW 120 M 150 x 2 05.012.27.02.0 SW 120 M 135 x 3 05.012.28.01.0 SW 120 M 155 x 3 05.012.29.01.0 SW 130 M 180 x 3 Order bolt separately. BPW code number: 02.5026.70.80 M 22 x 100		

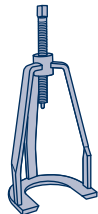
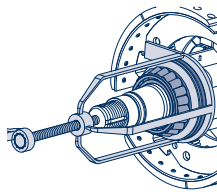
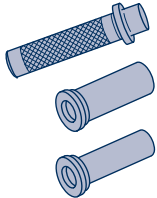
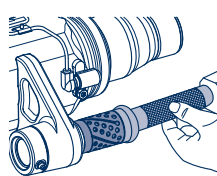
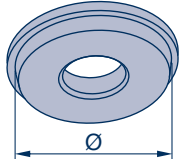
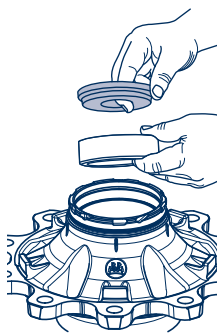
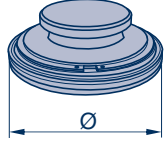
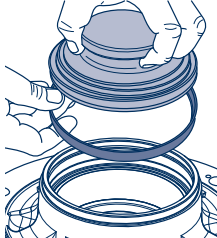
Number	Description	Illustration of tool	Tool in operation
9	Puller for taper roller bearings for axles 6.5 to 14 tonnes BPW code number: 02.0125.10.00		
10	Driving mandrel set for bearing bushes (camshaft and brake pins) BPW code number: 05.001.04.04.0		
11	Press tools for inserting the outer rings of roller bearings BPW code number: Roller bearing: 15.003.20052 Ø 138 32314 15.005.20052 Ø 100 32310 15.006.20052 Ø 202 32224 15.007.20052 Ø 188 32222 15.008.20052 Ø 160 32219 15.011.20052 Ø 142 33118 15.011.20052 Ø 142 33217 15.012.20052 Ø 123 33116 15.013.20052 Ø 113 33213 15.014.20052 Ø 123 33215		
12	Press tools for inserting ECO hub seal bearing rings BPW code number: Bearing race: 16.005.22111 Ø 139 02.5683.62.00 16.014.22111 Ø 159 02.5683.63.00 16.020.22111 Ø 157 02.5683.80.00		

5 Special tools

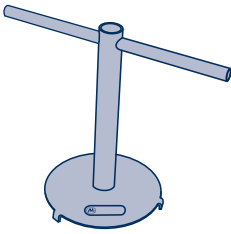
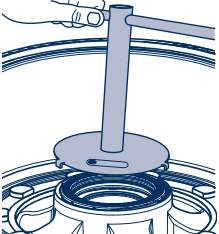
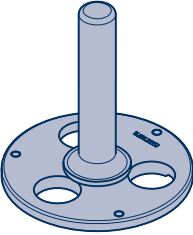
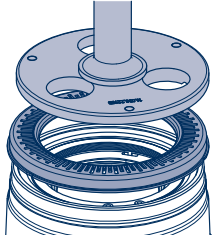
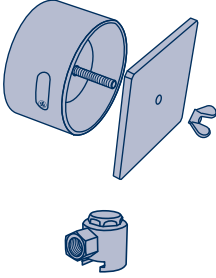
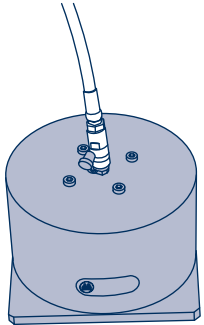
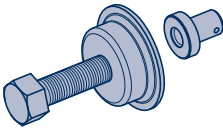
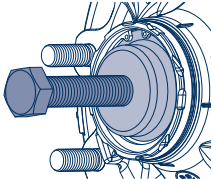
Number	Description	Illustration of tool	Tool in operation
13	Exciter ring assembly aid BPW code number: 16.020.22953 ECO ^{Plus} 8 - 9 t		
14	Exciter ring assembly aid BPW code number: 16.038.22953 ECO Plus 3		
15	Greasing tools for greasing roller bearings BPW code number: Roller bearing: 99.00.000.9.54 33116 / 32310 99.00.000.9.55 33118 / 33213 Complete set including adapter for flat grease nipple		
16	Puller for ECO Plus 2 BPW code number: 05.001.05.07.0		

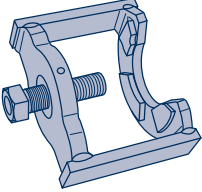
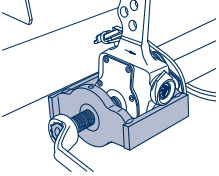
Number	Description	Illustration of tool	Tool in operation
17	Puller for slack adjusters BPW code number: 02.4306.15.00		

6 Lubrication and maintenance work

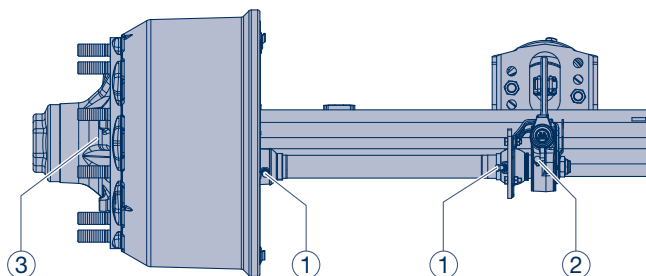

Lubrication

Overview

For detailed description see pages 24 to 35

Lubrication with BPW special longlife grease ECO-Li^{Plus}

	Every 12 weeks	Every 26 weeks ^{1) 2)}	Annually and at every brake lining replacement ^{1) 2)}	Annually	Every 2 years	Latest every 3 years or min. every 500,000 km ²⁾	Every 3 years	After 5 years, there-after every 3 years
① Brake camshaft bearing, outer and inner	On-Road conditions		①					
	Off-Road conditions	①						
	Outside Europe	①						
② Slack adjusters manual	②							
	Automatic slack adjuster ECO-Master							
	On-Road conditions		②					
Off-Road conditions	②							
	Outside Europe	②						
	③ Change wheel hub bearing grease, check taper roller bearings and rotary shaft seal for wear. ECO Plus 3, ECO Plus 2 and ECO ^{Plus} Unit:	On-Road conditions						
Off-Road conditions								③
Outside Europe: On-Road conditions					③			
Outside Europe: Off-Road conditions				③				
ECO Unit						③		
Outside Europe:				③				
Conventional hub bearing			③					

¹⁾ After a long idle period, prior to initial operation actuate the brake lever and lubricate the brake camshaft bearing.

²⁾ With usage extreme conditions (e.g. extreme Off-Road use) more frequent lubrication with high pressure grease is necessary.

For the positions ① to ② the use of a high-pressure central lubrication system which is capable of feeding special longlife grease of consistency class 2-3 is permissible. The use of liquid lubricants is not permitted!

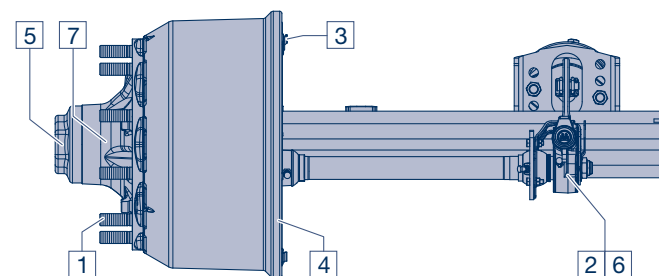

Maintenance work

Overview

For detailed description, see pages 36 to 45

Maintenance

	Initially	Every 1 to 3 weeks	Every 12 weeks	Every 26 weeks ²⁾	Annually and at every brake lining replacement ²⁾
① Check wheel nuts for tightness.	① ¹⁾				
② With manual slack adjusters, check brake play, adjust if necessary to 10 - 12% of the connected brake lever length and activate by hand or with 0.5 - 0.8 bar. (Not applicable in the case of automatic slack adjusters.)		②			
- Check the tyres for uneven wear, adjust the inflation pressure if necessary according to the manufacturer's specifications.			-		
③ Check brake lining thickness is at least 5 mm (SN 300 min. 7 mm).			③		
④ Check the brake drum for cracks and check the internal diameter.			④		
⑤ Check caps for firm seating (not necessary with ECO Plus 3, ECO Plus 2 and ECO ^{Plus} axles).					⑤
○ Visual inspection of all component parts and welding seams for damage and wear.			○ ³⁾	○	
⑥ Check operation of automatic slack adjusters.			⑥ ³⁾	⑥	
⑦ Check wheel hub bearing play, adjust if necessary.					
ECO Plus 3, ECO Plus 2 and ECO ^{Plus} Unit					⑦
ECO Unit, conventional bearing				⑦	

¹⁾ After the first run under load conditions, likewise after each wheel change.

²⁾ Under extreme conditions, increase frequency (e.g. construction sites and poor roads).

³⁾ For use outside Europe.

Note: Components that have damages due to improper mounting are to be exchanged after a review by a BPW Service Centre.

6 Lubrication and maintenance work

○ Lubricate

Note: After cleaning the vehicle with high pressure cleaners, all lubrication points must be relubricated.

① Brake camshaft bearing, outer and inner

- every year and with each brake lining change in On-Road use –
- every 6 months in Off-Road use and in use outside Europe –

**Prevent the vehicle from rolling away.
Release the service brakes and the handbrake.**

Lubricate the brake camshaft bearing through the grease nipple with BPW special longlife grease **ECO-Li^{Plus}** until fresh grease emerges from the bearing points.



Repair guide!
Use of other grease is not permitted.

② Slack adjusters (manual)

- quarterly –

Grease lubrication nipple with BPW special longlife grease **ECO-Li^{Plus}** until fresh grease emerges.

Automatic slack adjuster ECO-Master

- every year and with each brake lining change in On-Road use –
- every 6 months for Off-Road use and in use outside Europe –

Remove rubber seal cap. Grease with BPW special longlife grease **ECO-Li^{Plus}** (approx. 80 g) until sufficient new grease emerges from the adjustment screw.

Turn back adjustment screw (keep clutch sleeve pressed down) by approx. one turn using a ring spanner. Actuate the brake lever several times by hand. The adjustment must be carried out smoothly. If necessary, repeat several times.

Once again only use BPW special longlife grease **ECO-Li^{Plus}**.

Adjust the brake, see page 123.

Replace seal cap.

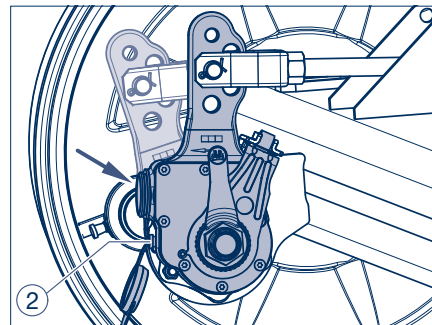
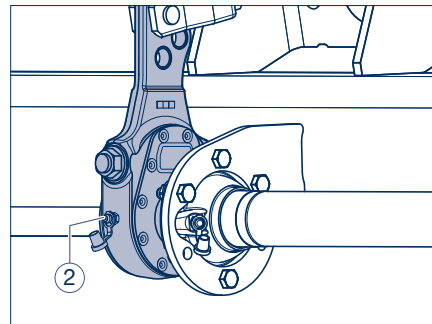
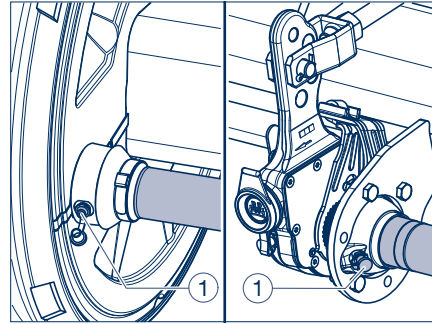

③ Change wheel hub bearing grease

🔧 ECO Plus 3 Unit

- for the first time after 5 years in on-road use, or every 3 years in off-road use in Europe, then at least every 3 years depending on operating conditions –
- every 2 years in on-road use or every year in off-road use outside Europe –

Thoroughly clean taper roller bearings and seals (using e.g. diesel oil), dry and check for re-useability. Replace grease seal.

(Recommendation: Renew the tapered roller bearings after 5 years in On-Road and after 3 years in Off-Road use.)

Work BPW special longlife grease **ECO-Li^{Plus}** thoroughly into the cavities between the taper rollers and the cage in both taper roller bearings. (For grease quantity see illustration on page 26.) Smear any residual grease into the hub's outer bearing race.

Smear the lip of the new seal all round with BPW special longlife grease **ECO-Li^{Plus}**.

Clean the bearing seats of the axle stub (metal must be bright, dry and free from grease). Spray with **BPW ECO Assembly and Protection Spray**. Allow to dry for about 10 minutes until the film changes to a marked matt colour.

Install ECO unit whilst continuously rotating axle nut of ECO unit. It is necessary to turn the ECO Unit numerous times before the gearing slips over the axle nut.



Important!
Do not use an impact driver.

Fit the retaining key in the groove between the stub axle and the nut (do not reset the axle nut).

Insert the hooked retainer spring behind the formed edge of the axle nut.

Insert a new O-ring into the annular groove of the wheel hub. Apply a thin coat of BPW special longlife grease **ECO-Li^{Plus}** to the O-ring contact surface and thread of the hub cap.

Screw on the hub cap and tighten to **350 Nm**.

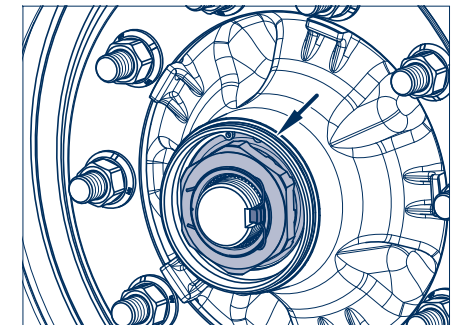
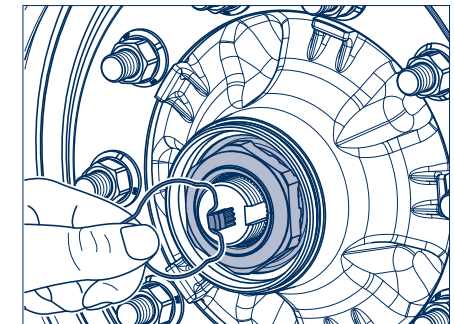
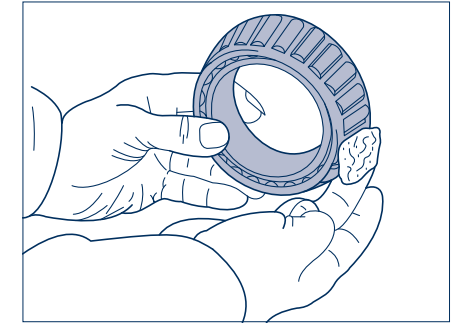

6 Lubrication and maintenance work

ECO Plus 3 Unit

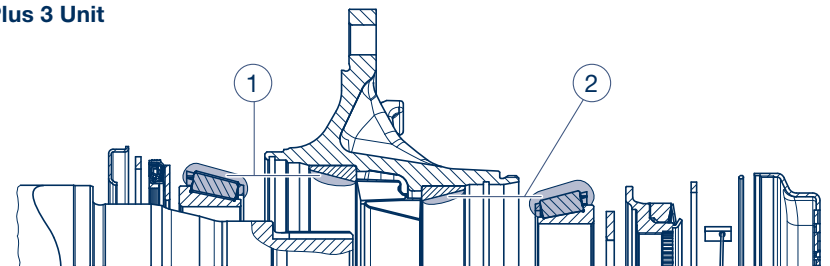

BPW special longlife grease ECO-Li^{Plus}
Grease quantity per taper roller bearing

	① inner bearing	② outer bearing
Manual greasing	170 g	120 g
Greasing with a grease applicator	130 g	90 g

ECO Plus 2 Unit

- for the first time after 5 years in on-road use, or every 3 years in off-road use in Europe, then at least every 3 years depending on operating conditions –
- every 2 years in on-road use or every year in off-road use outside Europe –

**Prevent the vehicle from rolling away.
Remove the wheel.**

Unscrew the cap with a 120 mm cap spanner.



Important!
Do not use an impact driver
- bayonet lock.

Undo the cap by turning it anti-clockwise by approx. 30° from position 1 to position 2.
When turned further the hub cap lifts clearly away from the ECO Unit and can be removed by pulling it away.

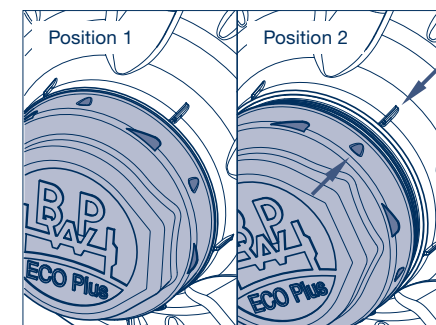
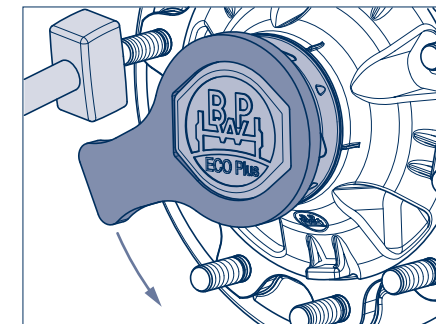

Remove the hooked spring ring and retaining key from the axle bolt.

Unscrew the axle bolt, pulling the complete ECO Unit off the bearing seats of the axle stub as you do so.

Dismantle the ECO Plus 2 Unit, see page 80.



Repair guide!
Mark both the hub and bearing to ensure correct positioning during re-assembly.
It is essential for the bearing inner races and rollers to be re-inserted in the same hubs.

Clean the tapered roller bearings thoroughly (e.g. with diesel oil), dry them and check if they can be re-used. Fit a new shaft seal.

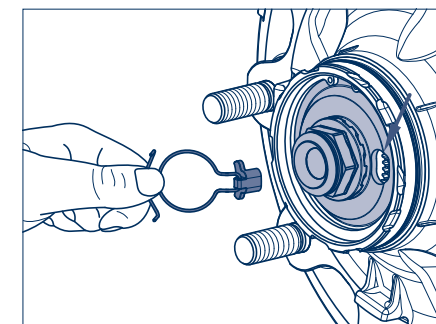

6 Lubrication and maintenance work



Note:
Renew the tapered roller bearings after 5 years in on-road use and after 3 years in off-road use.

Clean the grease cartridge and fill it on both sides up to the edge with BPW special longlife grease **ECO-Li^{Plus}**. It is important to ensure that it is filled without any air inclusions or cavities.

Apply a ring-shaped bead of grease to the running surfaces of the bearing outer races (see arrows in illustration below and picture 39 on page 85).

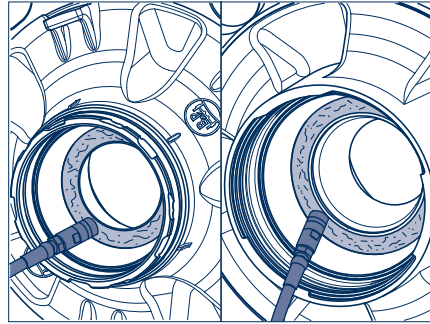

When BPW grease applicators are used, there is no need to fill the grease cartridge or to apply the bead of grease.

Mount the ECO Unit.

Clean the bearing seats of the axle stub (metal must be bright, dry and free from grease). Spray with **BPW ECO Assembly and Protection Spray**. Allow to dry for about 10 minutes until the film changes to a marked matt colour.

The threaded hole in the axle stub is only allowed to be lubricated with **ECO-Li^{Plus}**.



Repair guide!
Do not apply too much grease!
It is necessary to make sure that the thread of the axle bolt (446) can be completely screwed into the axle stub.

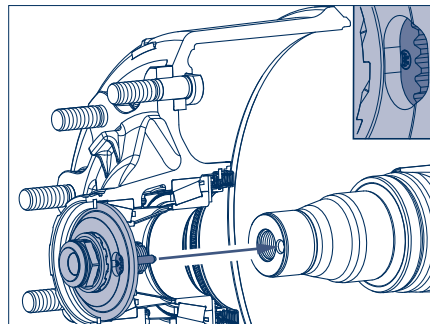

Mount the ECO Unit. Guide the toothed lock washer into the hole in the axle stub. The position of the pin can be seen by the indented BPW logo in the recess of the axle bolt.

Fasten axle bolt (SW46) whilst rotating the ECO hub unit. It is necessary to turn the ECO Unit numerous times before the gearing slips over the axle bolt (Do not turn back the axle bolt).

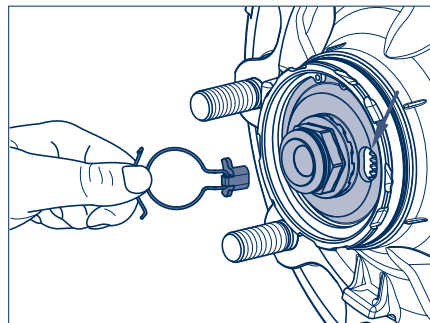

Important!
Do not use an impact driver.

Insert the retaining key into the hole recess of the axle bolt and the gearing of the toothed lock washer. (Do not turn back the axle bolt.)

Insert the hooked spring ring into the annular groove of the hexagon profile of the axle bolt.



Repair guide!
Make sure that the clasped spring ring assembly is correctly seated in the annular groove of the axle bolt.

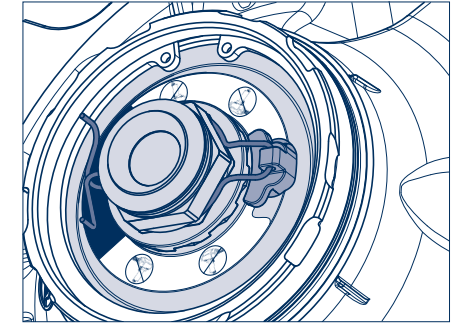

Insert a new O-ring into the groove in the wheel hub.

Apply a thin layer of BPW **ECO-Li^{Plus}** special longlife grease to the cap in the area of the O-ring contact surface and the bayonet fitting.

Screw on the cap with a 120 mm cap spanner.



Important!
Do not use an impact driver - bayonet lock.

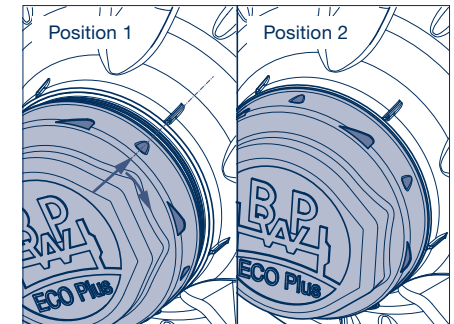

Push on the cap, see position 1.
Press on the cap and turn it by approx. 30° in a clockwise direction to lock it in place.
A tight seat is provided when position 2 is reached.

ECO Plus 2 Unit

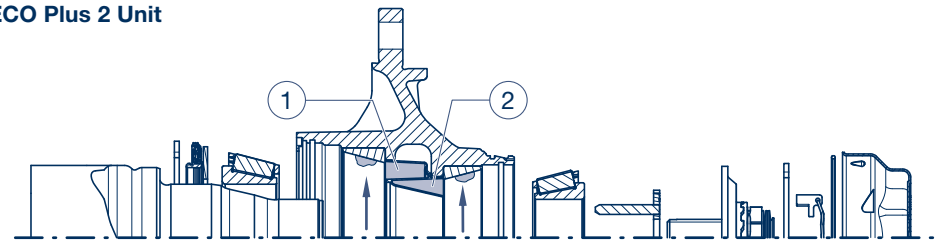

BPW special longlife grease ECO-Li^{Plus}
Grease quantity per taper roller bearing

	① inner bearing	② outer bearing
Manual greasing	170 g	120 g
Greasing with a grease applicator	130 g	90 g

6 Lubrication and maintenance work

ECO^{Plus} Unit

- for the first time after 5 years in on-road use, or every 3 years in off-road use in Europe, then at least every 3 years depending on operating conditions –
- every 2 years in on-road use or every year in off-road use outside Europe –

Remove and dismantle wheel hubs, see chapter 7/8.



Repair guide!

Mark both the hub and bearing to ensure correct positioning during re-assembly. It is essential for the bearing inner races and rollers to be re-inserted in the same hubs.

Clean taper roller bearings and seals (using e.g. diesel oil) thoroughly, dry and check for re-useability. Replace oil seal.



Recommendation:

Renew the tapered roller bearings after 5 years in on-road use and after 3 years in off-road use.

Work BPW special longlife grease **ECO-Li^{Plus}** thoroughly into the cavities between the taper rollers and the cage in both taper roller bearings. (For grease quantity see illustration on page 31.) Smear any residual grease into the hub's outer bearing race.

Smear the lip of the new seal all round with BPW special longlife grease **ECO-Li^{Plus}**.

Clean the bearing seats of the axle stub (metal must be bright, dry and free from grease). Spray with **BPW ECO Assembly and Protection Spray**. Allow to dry for about 10 minutes until the film changes to a marked matt colour.

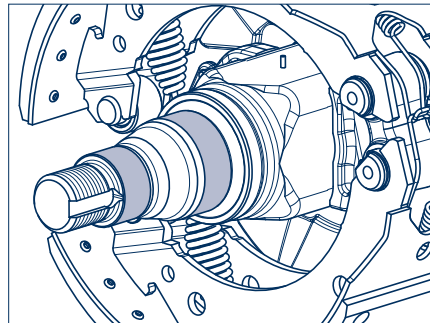
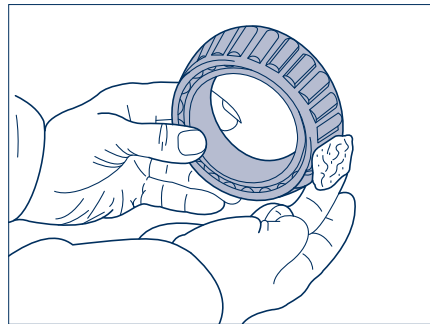
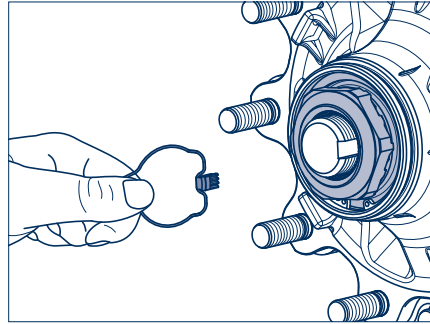

Fasten axle nut using a hexagon socket spanner whilst rotating the ECO hub unit. It should take several turns until the clutch on the axle nut slips.



Important!
Do not use an impact driver.

Fit the retaining key in the groove between the axle stub and the nut (do not reset the axle nut).

For production date April 2000 onwards, insert the hooked spring ring behind the edge of the axle nut or, up to March 2000, into the thread on the axle stub. Screw on the cap and tighten to 800 Nm.

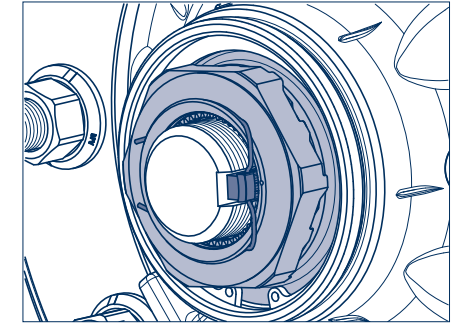

ECO^{Plus} Unit

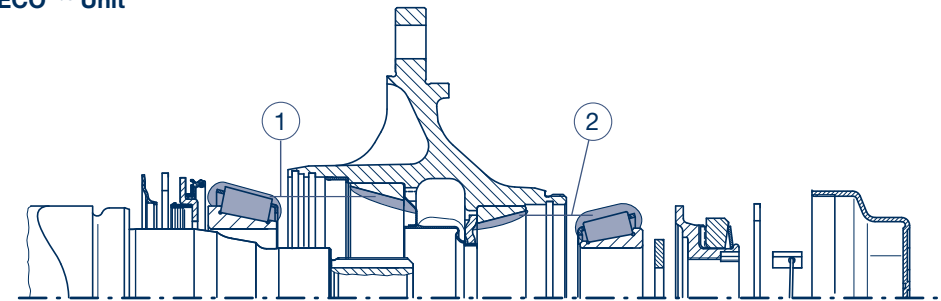

BPW special longlife grease ECO-Li^{Plus}
Grease quantity per taper roller bearing

	① inner bearing	② outer bearing
Manual greasing	170 g	120 g
Greasing with a grease applicator	130 g	90 g

6 Lubrication and maintenance work

ECO Unit

– latest every 3 years or min. every 500,000 km (Western European road conditions), annually in use outside Europe –

Remove and dismantle wheel hubs, see chapter 7/8.



Repair guide!

Mark both the hub and bearing to ensure correct positioning during re-assembly.

It is essential for the bearing inner races and rollers to be re-inserted in the same hubs.

Clean taper roller bearings and seals (using e.g. diesel oil) thoroughly, dry and check for re-useability. Replace oil seal.

Work BPW special longlife grease **ECO-Li^{Plus}** thoroughly into the cavities between the taper rollers and the cage in both taper roller bearings.

Comply with the total grease quantity in tables ① and ② on page 33.

Smear any residual grease into the hub's outer bearing race. Smear the lip of the new seal all round with BPW special longlife grease **ECO-Li^{Plus}**.

Clean the bearing seats of the axle stub (metal must be bright, dry and free from grease). Spray with **BPW ECO Assembly and Protection Spray**. Allow to dry for about 10 minutes until the film changes to a marked matt colour.

Fit the ECO Unit.

Fasten axle nut using a torque wrench whilst rotating the ECO hub unit. It should take several turns until the tightening torque has reached 150 Nm. Turn the nut back until the next securing position is aligned (max 15 degrees). Turn the nut back until the next securing position is aligned (max 15 degrees).

The next locking hole is reached by turning back the asymmetrical axle nut cap by a maximum of 15°.

Fit pin with a snap ring. Tighten the cap to 800 Nm.

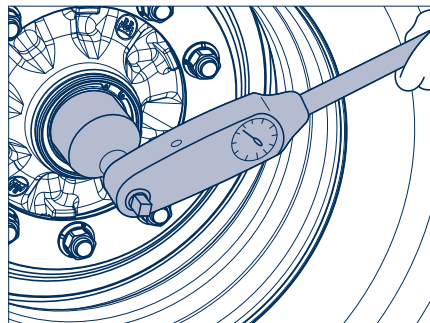
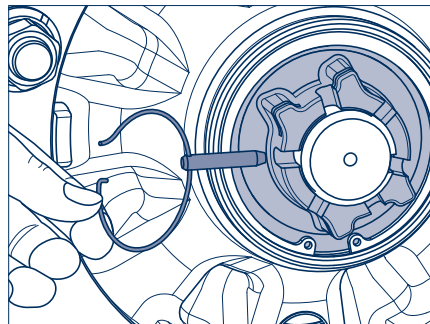
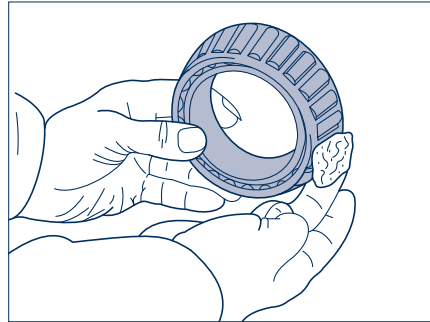

ECO Unit

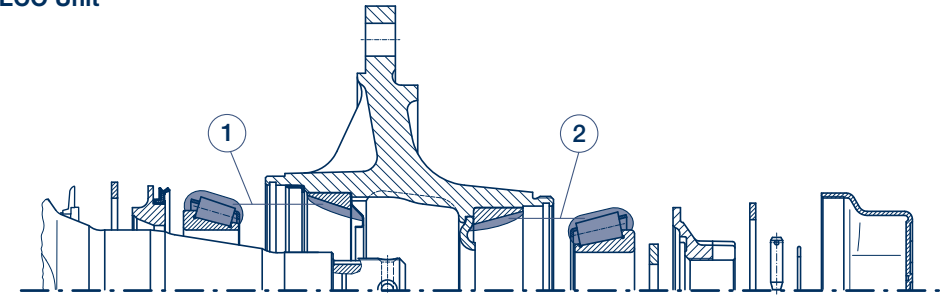

BPW special longlife grease ECO-Li^{Plus}

Grease quantity per taper roller bearing

Axle load	① Inner bearing	② Outer bearing
6000 - 9000 kg	120 g	120 g
10000 - 12000 kg	170 g	120 g
13000 - 14000 kg	230 g	150 g

6 Lubrication and maintenance work

Conventional hub bearing (change wheel hub bearing grease)

- whenever brake linings are changed, at the latest annually or after 150,000 km –

Remove and dismantle wheel hubs, see chapter 7/8.



Repair guide!

Mark both the hub and bearing to ensure correct positioning during re-assembly. It is essential for the bearing inner races and rollers to be re-inserted in the same hubs.

Clean wheel hubs thoroughly inside and outside. Clean taper bearings (using diesel oil) thoroughly, dry and check for re-useability.

Replace seals.

Work BPW special longlife grease ECO-Li^{Plus} into the cavities between the taper rollers and cage.

Comply with total grease quantity (table ① on page 35), smear any residual grease into the hub's outer bearing race.

Fit wheel hubs and adjust bearing play (see point 7 page 44).

Fill hub caps with BPW special longlife grease ECO-Li^{Plus} (table ②) and screw on.

For tightening torques see 5 page 40.



Repair guide!

For 16 - 18 t axles with BPW oval shape hub cap, a new O-ring must be fitted on reassembly.

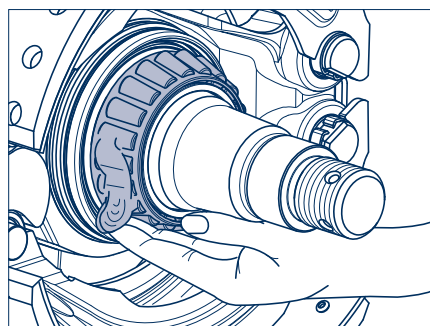
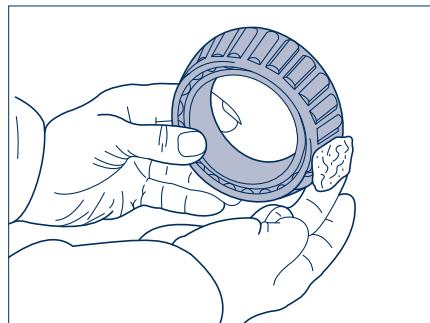

Conventional hub bearing

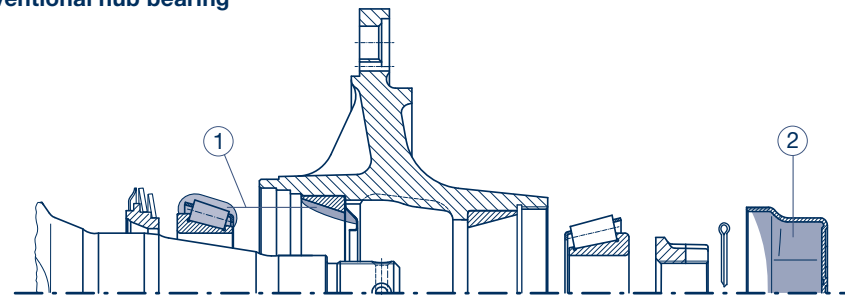

BPW special longlife grease ECO-Li^{Plus}

Grease quantity per taper roller bearing

Axle load	① inner bearing	② outer bearing (cap filling)
4000 - 5500 kg	80 g	130 g
6000 - 9000 kg	170 g	290 g
10000 - 12000 kg	180 g	320 g
13000 - 14000 kg	240 g	500 g
16000 - 18000 kg	400 g	800 g
20000 kg	440 g	900 g

6 Lubrication and maintenance work

Maintenance work

1 Check wheelnuts for tightness



– the tightening torque of the wheel nuts must be checked after the first high load journey as well as after each wheel change and, if appropriate, retightened to the prescribed value –

Tighten wheel nuts diagonally using a torque wrench to the tightening torque shown in the table.

In the case of Trilex wheels tighten the nuts consecutively several times around.

Wheel contact surfaces should not have additional coats of paint (risk of the wheels becoming detached!)

Tightening torques for wheel nuts

 It is imperative that the prescribed tightening torques are adhered to in order to ensure the wheels are securely fastened! The wheel studs must be clean and free of damage and the nuts must be easily tightened and loosened. If needed, lightly oil the contact surface between the wheel nut and the pressure disc. Do not oil or grease the thread of the wheel studs and wheel nuts. 

Stud alignment	Tightening torque	
M 14 x 1.5	125 Nm (120 - 130 Nm)	
M 18 x 1.5	290 Nm (275 - 305 Nm)	
M 20 x 1.5	380 Nm (360 - 400 Nm)	
M 22 x 1.5	510 Nm (485 - 535 Nm)	
M 22 x 2	460 Nm (435 - 485 Nm)	

Spigot alignment	Tightening torque	Wheel nut with collar
M 18 x 1.5	350 Nm (330 - 370 Nm)	
M 20 x 1.5	480 Nm (455 - 505 Nm)	
M 22 x 1.5	630 Nm (600 - 660 Nm)	
M 22 x 1.5 alloy wheels	630 Nm (600 - 660 Nm)	
M 24 x 1.5	860 Nm (820 - 900 Nm)	

Trilex wheels	Tightening torque	
M 18 x 2	285 Nm (270 - 300 Nm)	
M 20 x 2	335 Nm (320 - 350 Nm)	

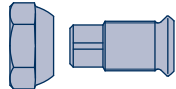
Japan connection	Tightening torque	
M 20 x 1.5	570 Nm (540 - 600 Nm)	
M 30 x 1.5	570 Nm (540 - 600 Nm)	

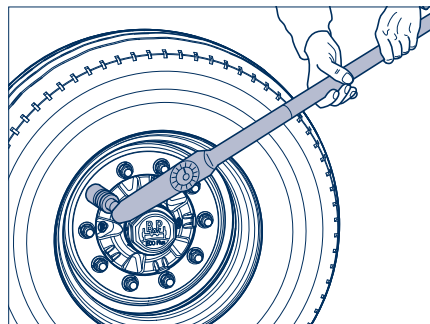

2 Check and adjust wheel brake play with manual slack adjusters

– frequent checks are necessary –
– depending upon application every 1 to 3 weeks –

Actuate slack adjusters by hand, pulling against the return spring. If there is more than 35 mm of play, the slack adjuster must be reset.

This can be done by adjusting the nut on the slack adjuster as shown.

Adjust the play "a" to 10 - 12% of the connected brake lever length "B", e.g. lever length 150 mm = 15 - 18 mm of play.

Automatic slack adjusters make this adjustment automatically whenever the camshaft is rotated by more than 17.5°.

 **Note:**
BPW brake cylinders with a round-hole yoke do not have an outer return spring.

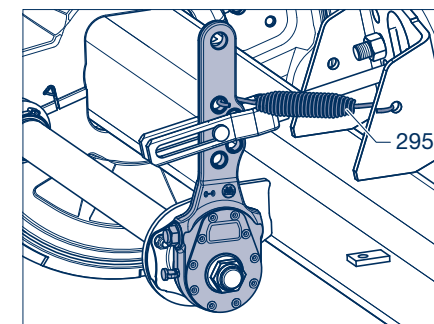
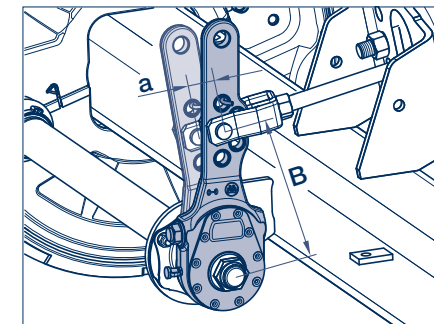

 Check the tyres for uneven wear, adjust the inflation pressure if necessary according to the manufacturer's specifications.
– quarterly –

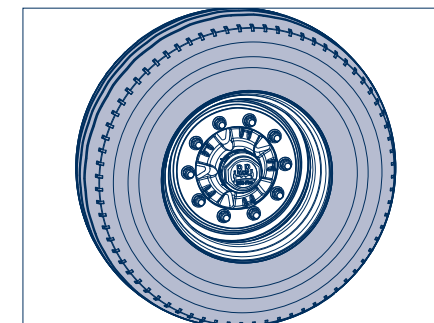

6 Lubrication and maintenance work

3 Check brake lining thickness – quarterly –

Open inspection hole by folding back the rubber flap (not required for brake type ECO Drum with hole on the outer dust cover edge).

The brake lining should be replaced at a residual lining thickness of 5 mm, SN 300 min. 7 mm (check with feeler gauge) or on reaching the bottom of the indicator machined into the edge of the lining.

Re-insert the rubber flap, if necessary.

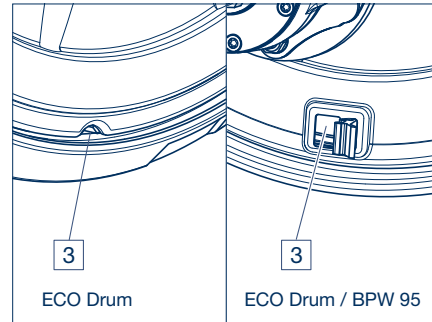

If brake lining wear indicators are fitted to the slack adjusters, the minimum thickness of the brake linings is indicated by the horizontal position of the lever (when the brake is released).

The Brake Monitor displays the "Service" signal when the wear sensor for drum brakes is installed. The green and yellow LED lights flash alternately. The service signal changes from black to red and remains in operation without voltage.

In certain cases the slack adjusters may not be fitted in the normal (i.e. vertical) position. In such instances, the position of the wear indicator will also be different. Linings should be changed when the wear indicator is approximately at right angles to the brake lever.

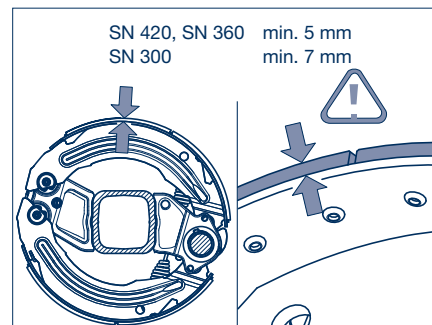
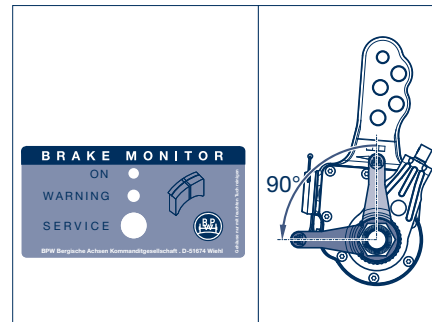

4 Check the brake drum for cracks and check the internal diameter – quarterly –

Check the condition of the brake drum and ensure there is adequate remaining thickness. If the wear is approaching the wear edge, measure the brake drum and renew it if the maximum permitted amount of wear has been reached.

Max. amounts of wear, measured at the position with the greatest wear:

Brake	Brake shoe width (mm)	Ø Max. amount of wear (mm)	Ø Max. skimming size (mm)
SN 420	120 / 160	424	423
SN 420	180 / 200 / 220	425.5	424
SN 360	160 / 200	364	363
SN 300	100 / 150 / 200	304	303

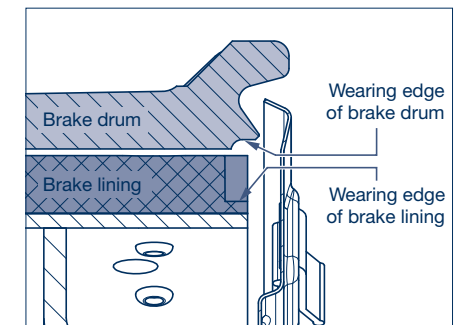
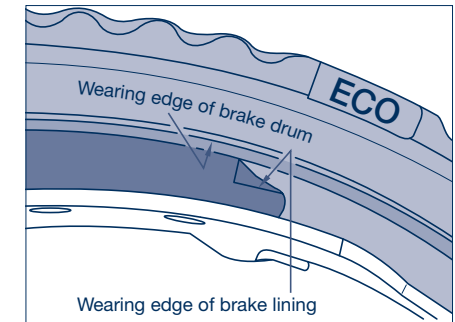
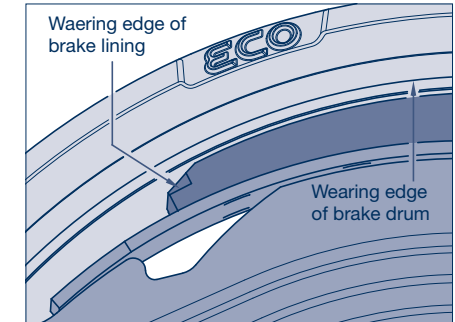

6 Lubrication and maintenance work

5 Check caps for firm seating

– every six months –
 (not necessary with ECO Plus 3, ECO Plus 2 and ECO^{Plus} axles)

Check caps for tightness using a torque wrench or power tool.

Tightening torques:

Hub caps with BPW oval shape:

ECO Plus 3 Unit	SW 110	350 Nm
ECO ^{Plus} Unit	8 - 12 t SW 110	800 Nm
ECO Unit	6.5 - 12 t SW 110	800 Nm
	13 - 14 t SW 120	800 Nm

Steel hub cap for conventional bearing hub

6.5 - 9 t	SW 95	500 Nm
10 - 12 t	SW 110	500 Nm
13 - 14 t	SW 120	800 Nm
16 - 18 t	SW 140	350 Nm

Alloy cap 6 - 12 t SW 110 350 Nm

Hub cap with octagonal shape:

13 - 20 t	SW 120	700 Nm
-----------	--------	--------

Caps with integrated hubodometers and BPW ECOMETER must be fitted and dismantled using only torque controlled (not impact!) air guns or manually with a torque wrench.

 Caps on ECO Plus 2 axles are provided with a bayonet fitting. Look and check for firm seating.

Position 1: Hub cap seated loosely on the unit.
 Position 2: Hub cap seated firmly on the unit.

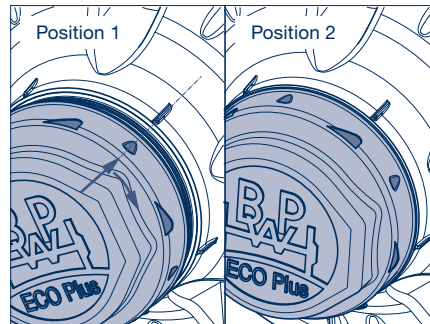
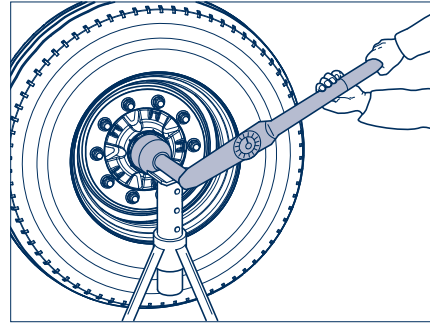

Visual inspection

– every 6 months –
 – quarterly in use outside Europe –

Check all components and welding seams for damage and wear.

6 Check operation of the automatic slack adjuster ECO-Master

– every 6 months –
 – quarterly in use outside Europe (e.g. within the scope of the statutory checks) –

**Prevent the vehicle from rolling away.
 Release the service brakes and the handbrake.**

Free play check:

Operate the slack adjuster by hand or with 0.8 bar. In the case, the idle stroke "a" corresponds to 10 - 15 % of the connected brake lever length "B", e.g. brake lever length 150 mm = idle stroke 15 - 22 mm.

Check the adjustment if the idle stroke is not within tolerance:

Remove rubber seal cap.

Turn back adjustment screw by approx. 3/4 of a turn in a counterclockwise direction using a ring spanner. Free play of at least 50 mm with a lever length of 150 mm must be available.

Actuate the brake lever several times by hand. When this is done automatic adjustment must take place smoothly. Engagement of the clutch coupling is audible and on the return stroke the adjustment screw turns slightly in a clockwise direction.

Grease with **ECO-Li^{Plus}**, see also ② on page 24.

Adjust the brake, see page 123.

Fit seal cap.

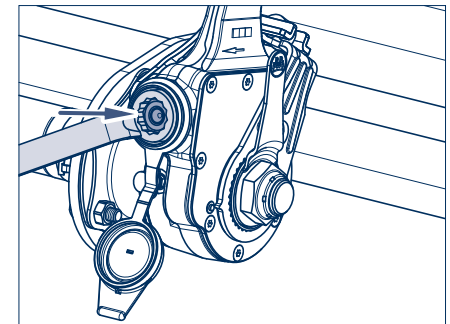
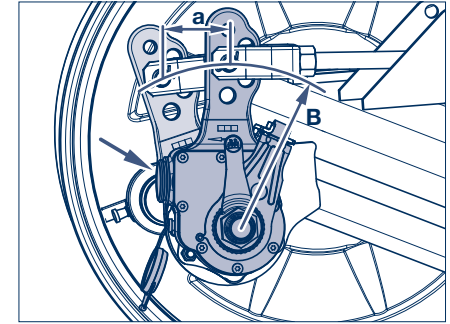

6 Lubrication and maintenance work

7 Check wheel hub bearing grease

- ECO Plus 3, ECO Plus 2 and ECO^{Plus} Unit at every brake lining replacement, latest annually –
- ECO Unit and conventional hub bearing every 6 months –

**Prevent the vehicle from moving away.
Release the service and parking brakes.**

In order to check the wheel hub bearing play lift the axle until the wheels are off the ground. Release the brake. Apply a lever between the tyre and the ground and check the play.

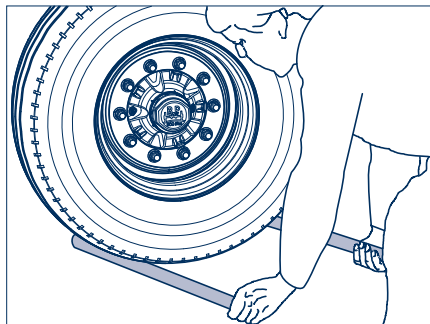

If bearing play is detected - **ECO Plus 3 Unit:**

Adjust the bearing play

1. Unscrew the cap.
2. Remove the hooked spring ring with a wedge from the axle nut.
3. Fasten axle nut using a hexagon socket spanner whilst rotating the ECO hub unit. It is necessary to turn the ECO Unit numerous times before the gearing slips over the axle nut.

 **Important!**
Do not use an impact driver.

4. Fit the retaining key in the groove between the stub axle and the nut (do not reset the axle nut).
5. Insert the hooked retainer spring behind the formed edge of the axle nut.
6. Insert a new O-ring into the annular groove of the wheel hub. Apply a thin coat of BPW special longlife grease ECO-Li^{Plus} to the O-ring contact surface and thread of the hub cap.
7. Screw on the hub cap and tighten to **350 Nm**.

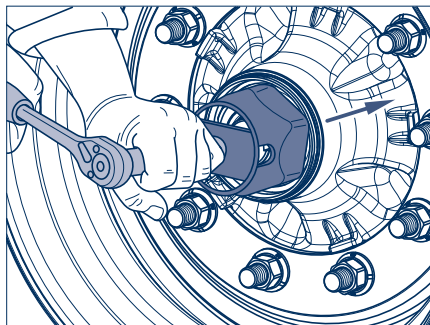
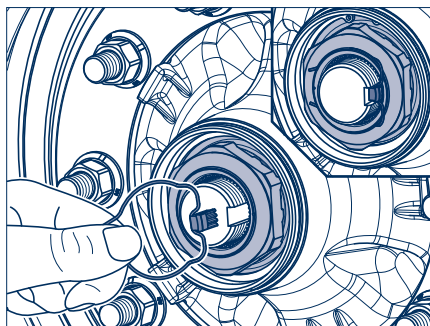

If bearing play is detected on **ECO Plus 2 Unit:**

Adjust the bearing play:

1. Unscrew the hubcap with a 120 mm hub cap spanner (BPW no. 03.339.05.02.0). Undo the cap by turning it anti-clockwise by approx. 30° from position 1 to position 2. When turned further the hub cap lifts clear away from the ECO Unit and can be removed by pulling it away.

 **Important!**
Do not use an impact driver - bayonet lock.

2. Remove the hooked spring ring with a wedge from the axle bolt.

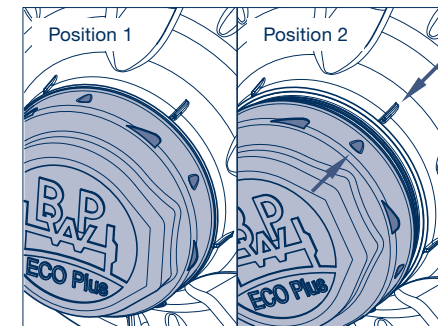
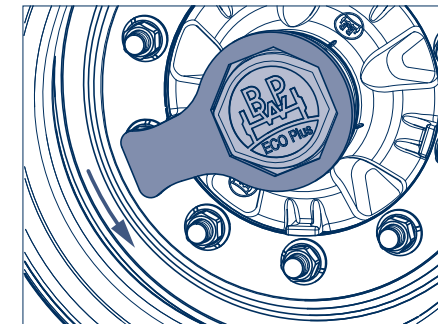

3. Fasten the axle bolt (SW 46) whilst rotating the ECO Unit. It is necessary to turn the ECO Unit numerous times before the gearing slips over the axle bolt.

 **Important!**
Do not use an impact driver.

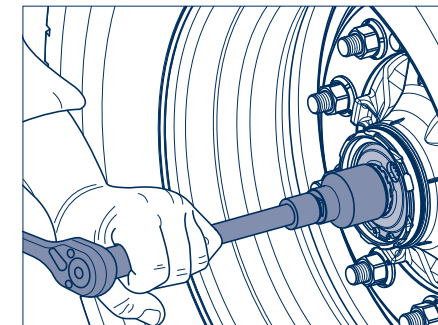

6 Lubrication and maintenance work

4. Insert the retaining key into the recess in the axle bolt and the gearing of the toothed lock washer. (Do not turn back the axle bolt.)
5. Insert the hooked spring ring into the groove on the hexagon profile of the axle bolt.



Repair guide!

Make sure that the clasped spring ring assembly is correctly seated in the annular groove of the axle bolt.

6. Insert a new O-ring into the groove in the wheel hub.

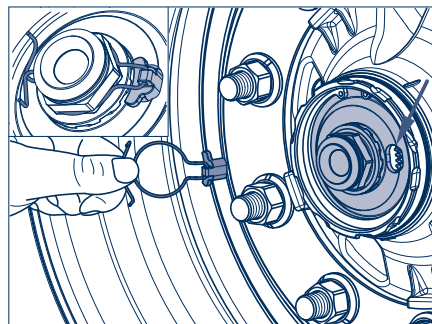

7. Apply a thin layer of BPW ECO-Li^{Plus} special longlife grease to the hubcap in the area of the O-ring contact surface and the bayonet fitting.
8. Replace the cap with a 120 mm cap spanner.



Important!
Do not use an impact driver - bayonet lock.

Push on the cap, see position 1.
Press on the cap and turn it by approx. 30° in a clockwise direction to lock it in place.
A tight seat is provided when position 2 is reached.

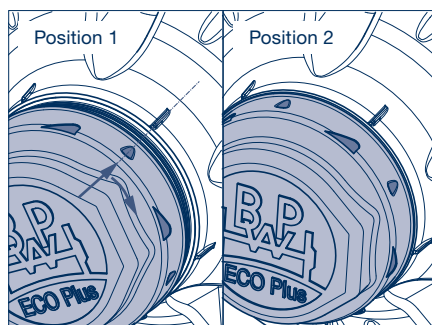

If bearing play is detected on **ECO^{Plus} Unit**:

Adjust the bearing play:

1. Unscrew the hubcap.
2. Remove the hooked spring ring with a wedge from the axle nut.
3. Fasten axle nut using a hexagon socket spanner (BPW no. 05.364.26.05.0) whilst rotating the ECO Unit. It should take several turns until the clutch on the axle nut slips.



Important!
Do not use an impact driver.

4. Fit the retaining key in the groove between the axle stub and the nut (do not reset the axle nut).
5. For production date April 2000 onwards, insert the hooked spring ring behind the edge of the axle nut or, up to March 2000, into the thread on the axle stub.
6. Tighten the hubcap to 800 Nm.

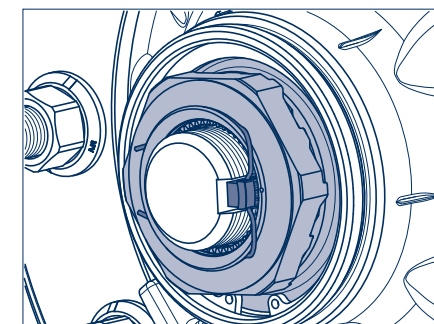
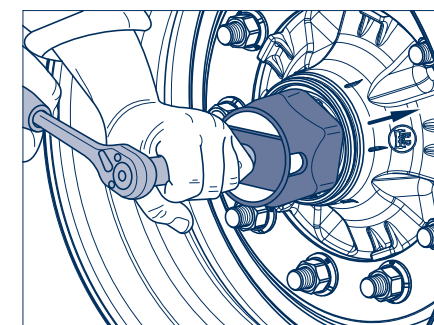
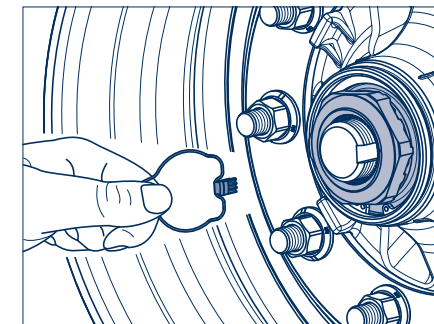

6 Lubrication and maintenance work

If bearing play is detected on **ECO Unit**:

Adjust the bearing play:

1. Unscrew the cap.
 2. Loosen axle nut.
 3. Fasten axle nut using a torque wrench whilst rotating the ECO hub unit. It should take several turns until the tightening torque has reached 150 Nm.
- If a normal axle nut spanner is used (vehicle tool kit), tighten the axle nut until the ECO Unit drags slightly (auxiliary solution).
4. Turn back axle nut to the next locking position (max. 15°). The asymmetrical cap of the axle nut enables the next locking position to be reached after turning back max. 15°.
 5. Insert bolt and locking ring.
 6. Screw on cap.

Tightening torque:

Steel / cast cap	800 Nm
Aluminium cap	350 Nm

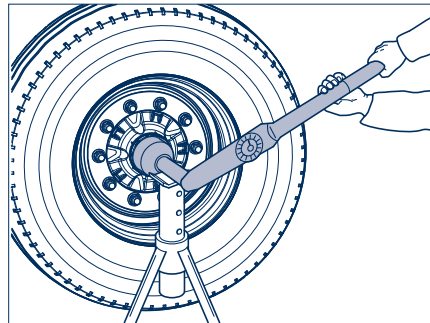
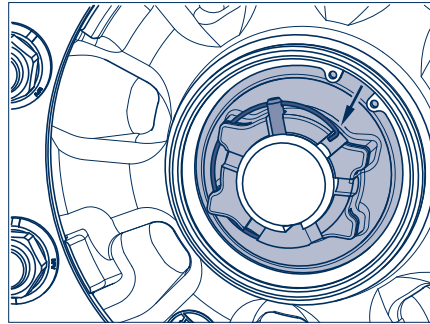
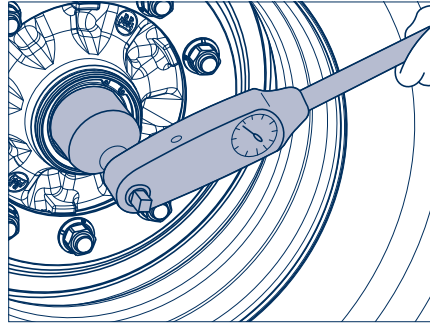

If bearing play is detected in **conventional hub bearing**:

Adjust the bearing play:

1. Unscrew the cap.
2. Remove the split pin from the axle nut.
3. Fasten the axle nut using a torque wrench and with the continuous turning of the wheel hub. It should take several turns until the tightening torque has reached the desired value.

Tightening torques:

Hub caps with BPW oval shape:

- Up to an axle load of 5.5 tons = 70 Nm,
- from 6 to 18 tons axle load = 150 Nm,

Hub caps with octagonal shape:

- from 16 to 30 tons axle load = 350 Nm

- If a normal axle nut spanner is used (vehicle tool kit), tighten the axle nut until the wheel bearing race drags slightly.
4. Turn back the axle nut to the next available split pin hole. Should they already be in line turn back to the next hole (30° at the maximum). (Does not apply to the ECO Plus 3, ECO Plus 2, ECO^{Plus} and ECO Unit.)
 5. Insert the split pin and bend upwards slightly.
 6. Refill the cap as required with BPW special longlife grease ECO-Li^{Plus} and replace.

For tightening torques see point [5](#) page 40.



Repair guide!

For 16 - 18 t axles with BPW oval shape hub cap, a new O-ring must be fitted on reassembly.

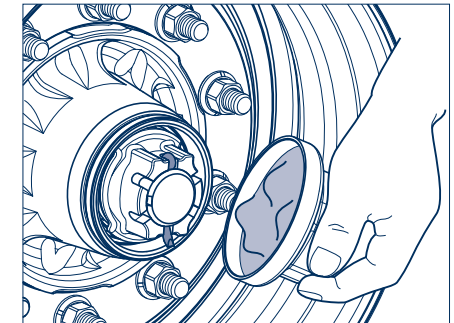
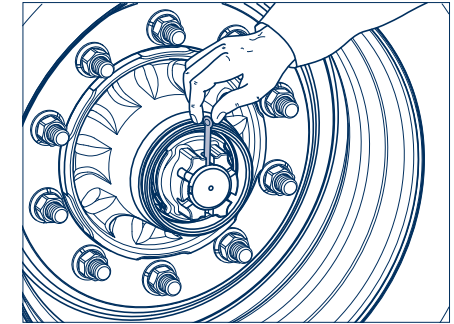
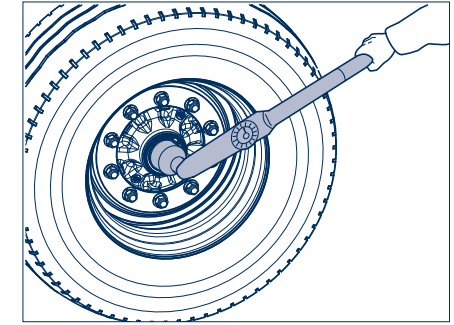

7 Changing the brake lining

To check the brake lining thickness, open the inspection hole by pulling the rubber flap (520) (not required for brake type ECO Drum with hole on the outer dust cover edge).

If the remaining thickness of the lining is 5 mm or less (or when the bottom edge of the wear pocket on the brake lining is reached), the brake lining must be renewed.

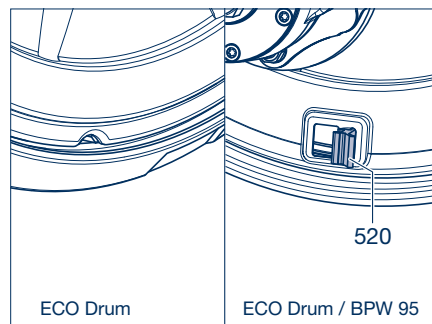

Picture 1

7.1 Removal of the wheel hub / brake drum unit

 During dismantling / assembling the wheel can remain mounted on the wheel hub.

We recommend removing the wheel to facilitate handling of the hub/drum unit when changing the bearing.

[1] Prevent the vehicle from rolling away and release the brakes.

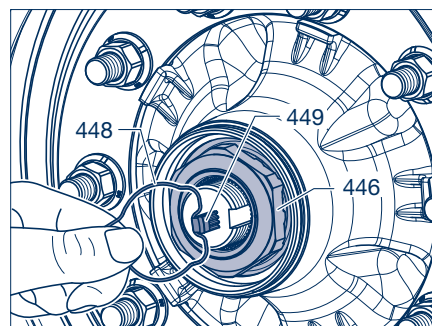

Picture 2

ECO Plus 3 and ECO^{Plus} Unit:

[2] Unscrew the cap (460) from the wheel hub.

[3] Support the vehicle in such a way that an accident cannot occur. Raise the axle until the tyres are free.

[4] Remove the hooked spring ring (448) and retaining key (449) from the axle nut (446).

[5] Unscrew the axle nut (446).

 Unscrew the axle nut to withdraw the complete wheel, hub, drum, bearing and seal arrangement from the stub axle.

[6] Remove the complete hub bearing unit sideways from the axle (wheel mounting trolley).

The brake is now accessible, continue with working step [8].

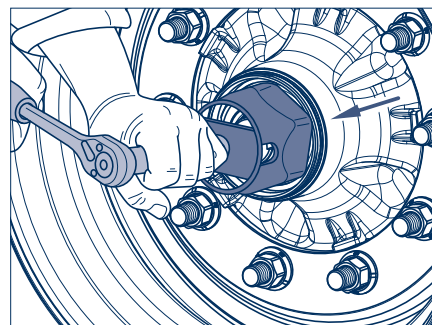

Picture 3

ECO Plus 2 Unit:

[2] Unscrew the cap (460) with a 120 mm cap spanner.

 **Important!**
Do not use an impact driver - bayonet lock.

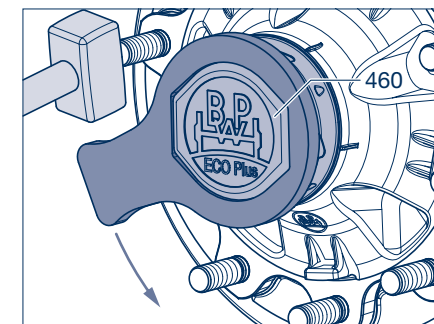

Picture 4

[3] Undo the cap (460) by turning it anti-clockwise by approx. 30° from position 1 to position 2. When turned further the hub cap lifts clearly away from the ECO unit and can be removed by pulling it away.

[4] Support the vehicle in such a way that an accident cannot occur. Raise the axle until the tyres are free.

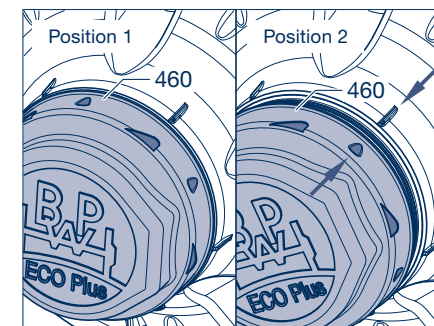

Picture 5

[5] Remove the hooked spring ring (448) and retaining key (449) from the axle bolt (446).

[6] Unscrew the axle bolt, pulling the complete ECO Unit off the bearing seats of the axle stub as you do so.

[7] Remove the complete hub bearing unit sideways from the axle (wheel mounting trolley).

The brake is now accessible, continue with working step [8].

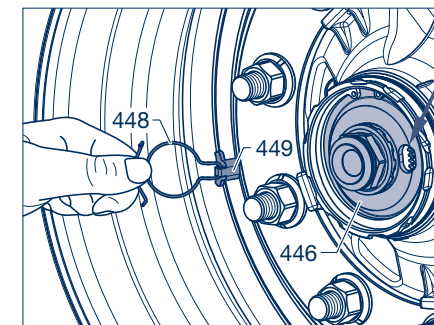

Picture 6

7 Changing the brake lining

ECO Unit:

- [2] Unscrew the cap (460) from the wheel hub.
- [3] Support the vehicle in such a way that an accident cannot occur. Raise the axle until the tyres are free.
- [4] Remove the hook spring ring (448), complete with retention pin (447), from the axle nut (446).

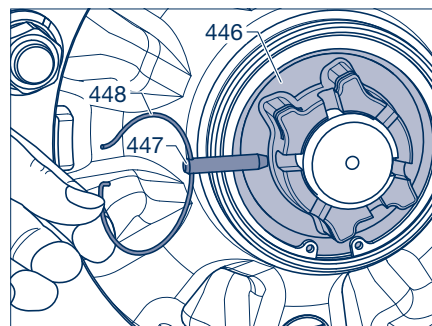

Picture 7

- [5] Unscrew the axle nut (446).

 Unscrew the axle nut to withdraw the complete wheel, hub, drum, bearing and seal arrangement from the stub axle.

- [6] Remove the complete hub bearing unit sideways from the axle (wheel mounting trolley).

The brake is now accessible, continue with working step [8].

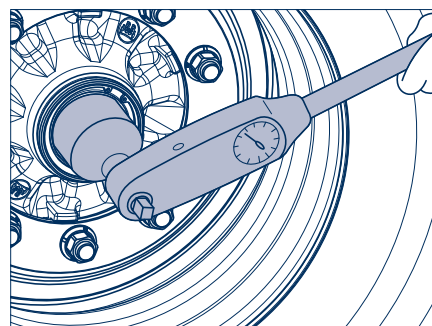

Picture 8

Conventional hub bearing:

- [2] Unscrew the cap (460) from the wheel hub.
- [3] Support the vehicle in such a way that an accident cannot occur. Raise the axle until the tyres are free.
- [4] Remove the split pin (447) from the axle nut (446) and unscrew.

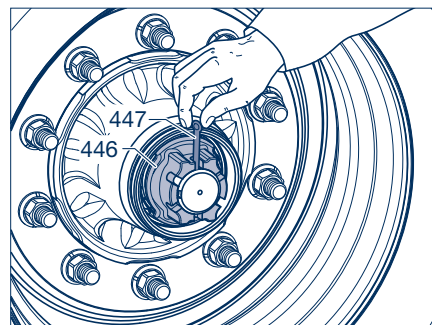

Picture 9

- [5] Using the hub puller (BPW no. see page 18). Withdraw the wheel hub unit with the wheels from the axle stub.

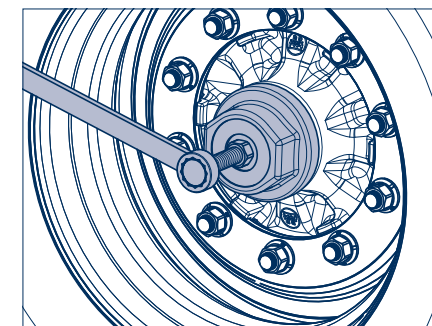

Picture 10

- [6] Position puller. Pull off the inner taper roller bearing (430), the grease seals (422, 423) and the thrust washer (420) together from the axle stub.

Extractor:
BPW no. 02.0125.10.00 for axles 6.5 to 14 t.



Repair guide!
For 10 t axle series K with ABS/
ABV: Unscrew the sensor holder (542).



Repair guide!
Mark both the hub and bearing to
ensure correct positioning during
re-assembly.
It is essential for the bearing inner
races and rollers to be re-inserted
in the same hubs.

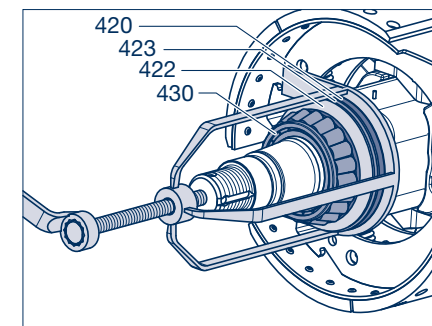

Picture 11

7.2 Changing the brake lining

- [8] Remove rubber seal cap (283) from the slack adjuster (280).
- [9] Turn back adjustment screw (arrow) in a counter-clockwise direction using a ring spanner.
- [10] Reset slack adjuster (280) until the S-cam of the brake cam shaft (240, 241) reaches the zero position.

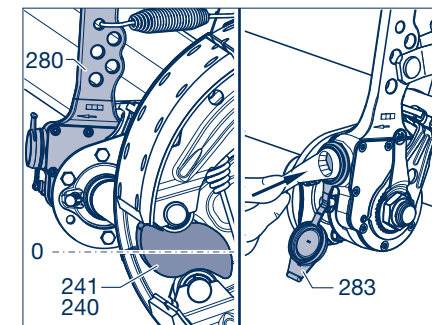

Picture 12

7 Changing the brake lining

- [11] Lever the positioning springs (367, 368) apart using a screwdriver.

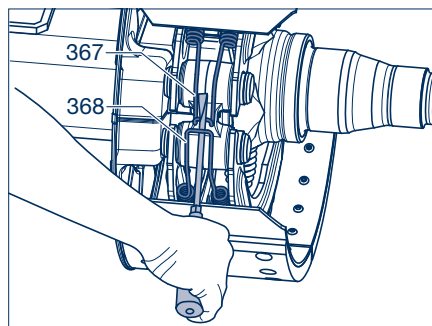

Picture 13

- [12] Place assembly lever on axle beam and lift brake shoes (330).



Repair guide!
When lifting, protect the sensor (570) and the sensor cable from damage.

Remove brake shoes.

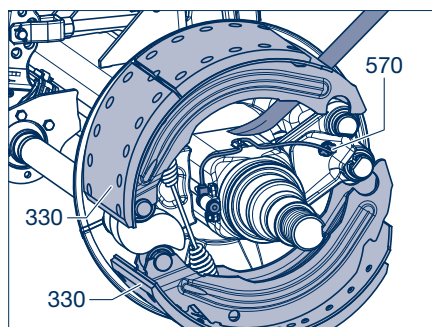

Picture 14

- [13] Remove either one or two tension springs (363), depending on the design, from the tabs on the brake shoes (330)

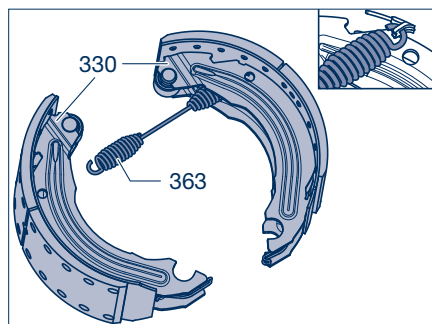

Picture 15

- [14] Remove the positioning springs (367, 368 / arrow) from the brake shoes (330).

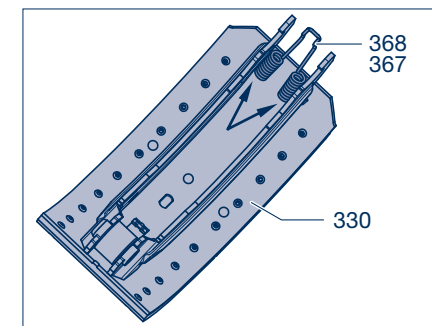

Picture 16

- [15] Remove the old brake lining and clean the brake shoe. The surface must be free of rust and be smooth.



Repair guide!
The rivets (357) should always be pressed out using a riveting machine, preferably with hydraulic actuation. The equipment used must be suitable for the rivet diameter. Modern rivet punches can universally accept hollow and semi hollow rivets.

The use of unsuitable rivet punches may damage the brake shoe.

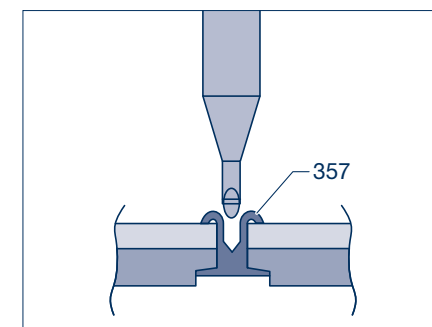

Picture 17

If there is no riveting machine available:

Shear off the closed head of the rivet with a chisel (No. 1) or remove the closed head using 8.6 mm diameter drill bit. (No. 2). Drive out the rivet with a punch (No. 3).

- [16] Check the diameter of the rivet hole using a rivet hole gauge. The diameter is not allowed to be more than 0.6 mm larger than the rivet diameter (DIN 7513).

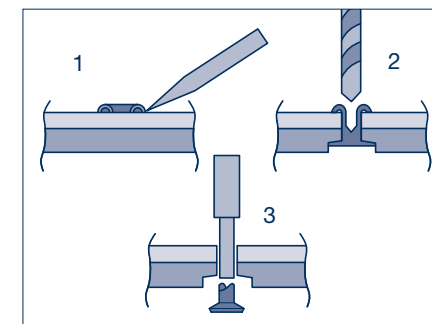

Picture 18

7 Changing the brake lining

Frequent faults

- 1 Loose rivets indicate enlarged rivet holes
- 2 Rivet hole damaged during boring
- 3 Damaged platform edge
- 4 Worn shoe support
- 5 Deformed shoe web
- 6 Rivet hole deformed during boring
- 7 Rivet hole damaged by riveting machine
- 8 Corroded platform area
- 9 Damaged shoe web end
- 10 Worn shoe roller bearings
- 11 Cracked welding seam
- 12 Damaged platform surface
- 13 Corroded welding seam
- 14 Deformed platform surface

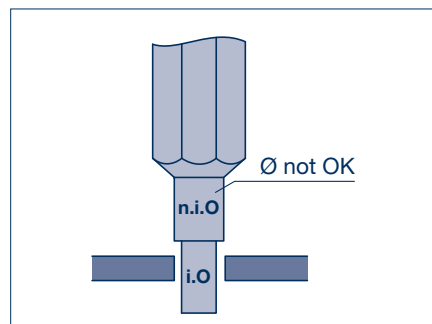

Picture 19

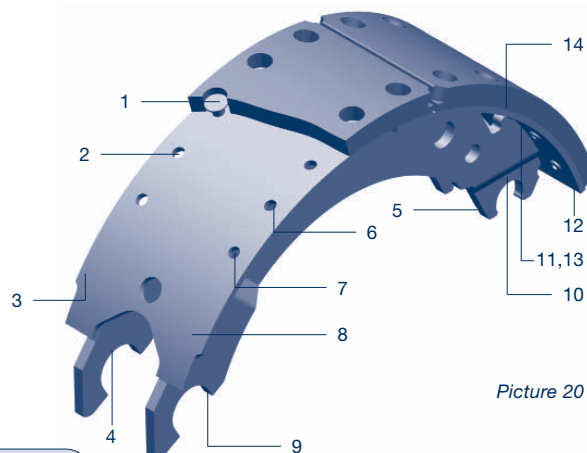

Picture 20



Repair guide!

With skimmed brake drums use corresponding oversize brake linings.

The brake shoe must snugly fit on the platform, i.e. the platform must not be concave. The shoes must be carefully cleaned, e.g. by sandblasting by means of a shoe grinding unit.

- [17] Insert all rivets and hold in position by crimping edges. Rivet brake lining (350) into place taking care to follow the correct riveting order (picture 22).

Series K (SN 360):

Note different lengths of brake lining segments. Assemble the short brake lining segment (351, arrow) to the roller end.

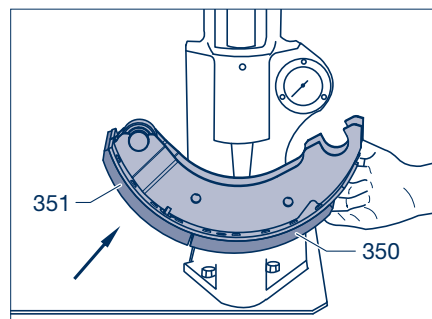

Picture 21

- ✎ Rivet as shown from the inside out.

Riveting force: **21000 N** (20000 - 22000 N)

Rivets: Semi-tubular rivets, galvanized steel
8 x 15 mm meeting DIN 7338 B

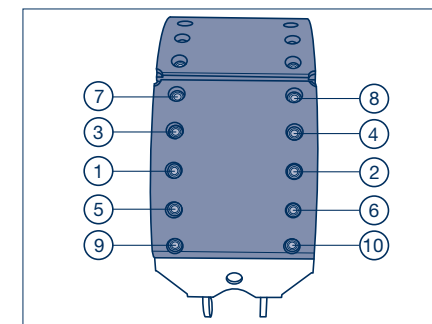

Picture 22

7.3 Riveting check

Picture 23, Pos. 1:

Rivet length correct, the hole inner wall and strength are correct.

Picture 23, Pos. 2:

Rivet too short, no inner hole recess and poor closing head formation.

Picture 23, Pos. 3:

Rivet too long, inadequate closing head, crack formation.

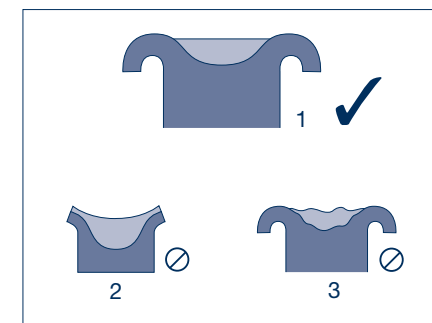

Picture 23

- ✎ A light tap with a hammer will determine whether the riveting is satisfactory or not. A dull thud indicates a loose lining. A high-pitched response indicates that the riveting is correct.

- ✎ A feeler gauge can be used to check for cavities under the lining. A cavity of more than 0.15 mm beyond the first row of rivet holes can lead to noise problems.

- ✎ Finally, the linings should be checked for cracks in the area of the rivets which would indicate incorrect riveting.

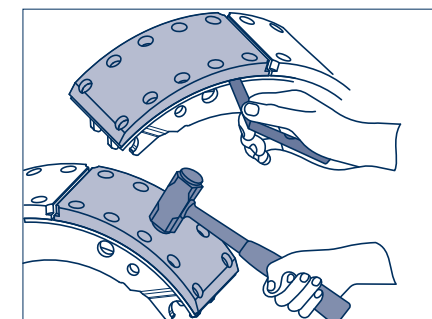

Picture 24

7 Changing the brake lining

Health and safety precautions

Brake dust contains large volumes of breathable fine dust and is hazardous to your health, even in case of non-asbestos material. Safety regulations prescribe extraction systems with a suction power between 40 and 50 m³/h.

Wheel brakes must never be cleaned down using compressed air or cleaned using a dry brush.

It is strongly recommended to use clean water without chemical additives or a special vacuum cleaner machine to clean down the brakes. The use of detergents might impair the braking effect.

7.4 Brake shoe installation

- [18] Check roller (345) for wear, renew as appropriate. Remove bearing bolts (346).

 **Repair guide!**
In the event of wear, exchange roller bearing bolts and rings.

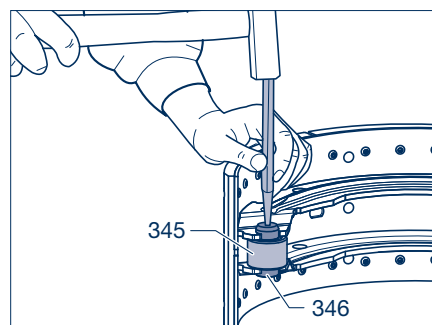

Picture 25

- [19] Clean bearing bush and apply BPW special longlife grease ECO-Li^{Plus} (4 g).

- [20] Insert new roller (345) with rings (348) into the brake shoe webs.

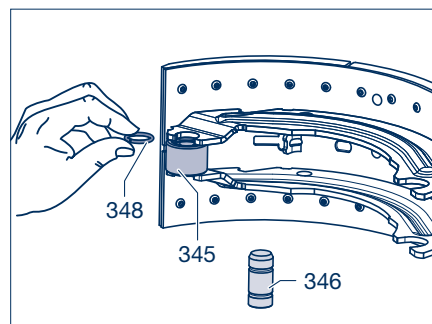

Picture 26

- [21] Drive in bearing bolt (346) with the bevelled side down until both rings (348) snap into the annular grooves of the bearing bolt.

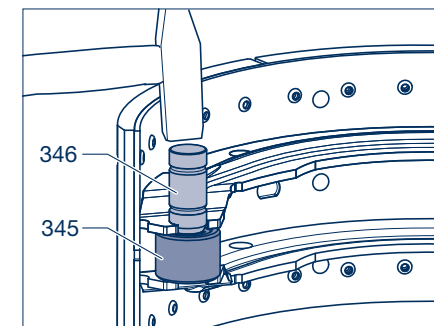

Picture 27

 **Repair guide!**
Insert new return springs every time the brake linings are changed.

Serie H (SN 420):

- [22] Insert the return springs (363) into the lugs of the brake shoes (330).

Serie N (SN 300):

- [22] Insert two return springs (363) into the lugs of the brake shoes (330).

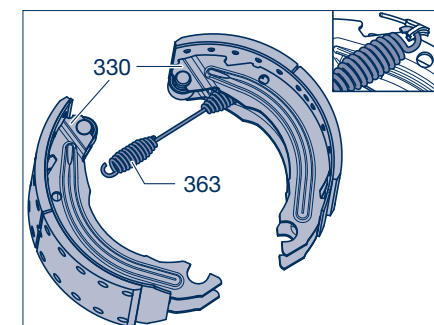

Picture 28

Serie K (SN 3620):

- [22] Hook both return springs (363) into the lugs on the outside of the brake shoes (330).

Serie K (SN 3616):

- [22] Hook a return spring (363) into the lugs on the outside of the brake shoes (pointing towards the middle of the axle), see picture 36 page 58.

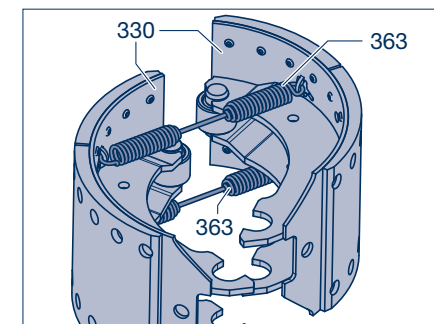

Picture 29

7 Changing the brake lining

- [23] Hook the positioning springs (367, 368 / arrow) into the brake shoes (330).

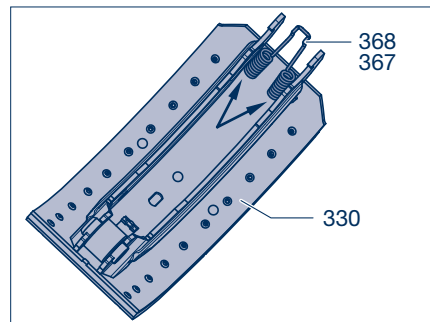

Picture 30

Only for models with ABS/ABV

- [24] Check sensor (570) for damage and displacement (displacement force 100 - 200 N). If necessary, smear clamping bush (571) and sensor with special grease (replace clamping bush). Before fitting hubs, always press clamping bush and sensor up to endstop. When fitting the hub, the sensor will be pushed back into the correct position by the exciter ring (560).

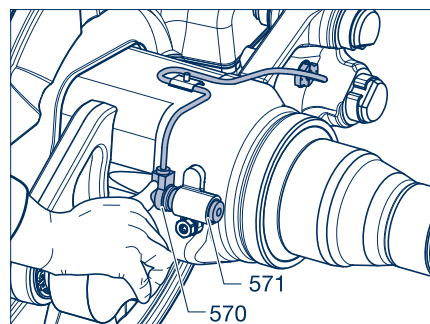

Picture 31

7.5 Installation of the brake shoes

- [25] Check hooked spring rings (325) on the brake anchor plate for wear and seating. If necessary, change components.



Repair guide!
Hooked spring rings must be renewed when the brake lining is changed, if not before.

- [26] Smear BPW special longlife grease **ECO-Li^{Plus}** onto bearing points (arrows) of brake shoes.

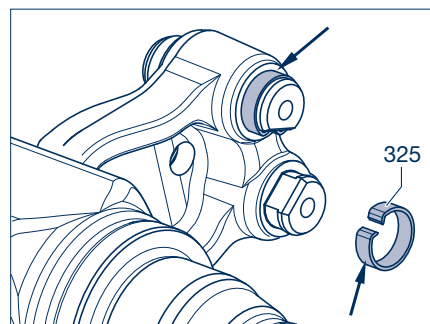

Picture 32

- [27] Place upper brake shoe (330) with the roller (345) on to the S-cam.

- [28] Fix brake shoe on to the spring ring (325) by hitting lightly with a soft hammer.

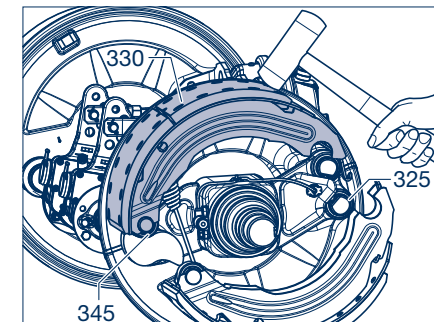

Picture 33

- [29] Assemble lower brake shoe (330) and fix on to the spring ring (325) by hitting lightly with a soft hammer.

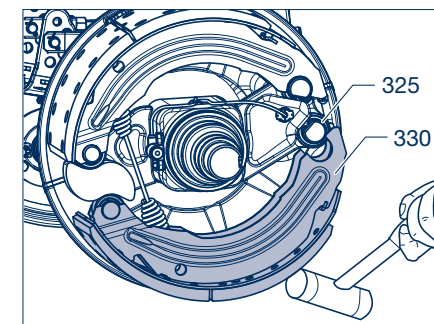

Picture 34

- [30] Link the positioning springs (367, 368) using a screwdriver.

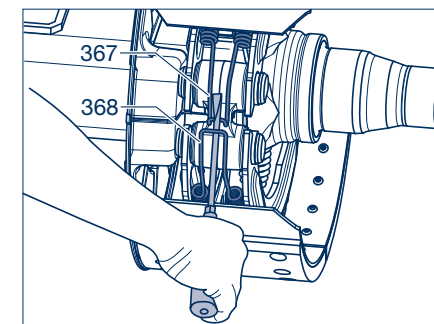

Picture 35

7 Changing the brake lining

Series K (SN 3616):

Secure the outer return springs (365) onto the lugs of the brake shoes and hook into the plate (366).

Insert the plate (arrow) into the groove on the pin of the brake camshaft (240, 241).

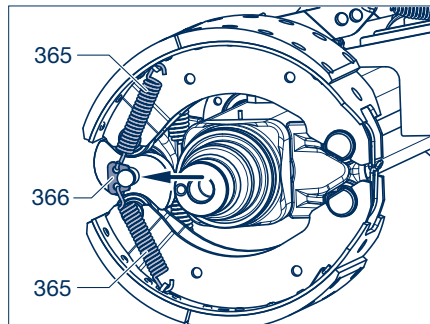

Picture 36

All brakes

[31] Expand brake to small extent.

[32] Using a brake lathe turn down the brake linings to fit the brake drum diameter until an even wear surface has been obtained.



Repair guide!

There is no need to machine the brake linings when fitting genuine BPW replacement lined brake shoe assemblies.

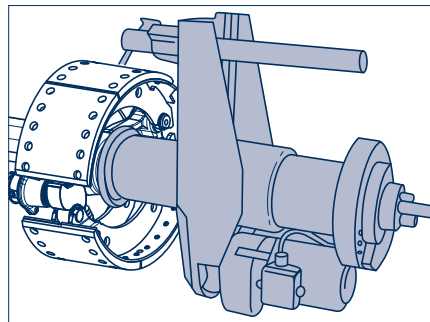

Picture 37

[33] Check the condition of the brake drum and ensure there is adequate thickness remaining. If the wear is approaching the wear edge, measure the brake drum and renew it if the maximum permitted amount of wear has been reached.

Max. amounts of wear, measured at the position with the greatest wear:

Brake	Brake shoe width (mm)	Ø max. amount of wear (mm)	Ø Skimming size (mm)
SN 420	120 / 160	424	423
SN 420	180 / 200 / 220	425.5	424
SN 360	160 / 200	364	363
SN 300	100 / 150 / 200	304	302

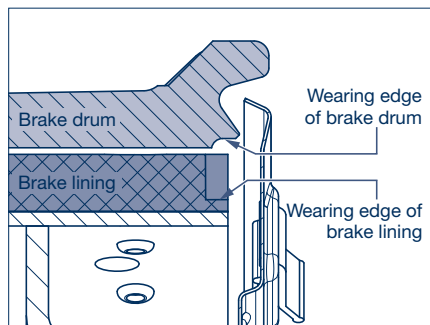

Picture 38

7.6 Installation of the wheel hub brake drum unit

ECO Plus 2 Unit, see page 63.
ECO Unit, see page 65.
Conventional hub bearing, see page 67.

ECO Plus 3 and ECO^{Plus} Unit:

[34] Clean the bearing seats of the axle stub (metal must be bright, dry and free from grease). Spray with **BPW ECO Assembly and Protection Spray**. Allow to dry for about 10 minutes until the film changes to a marked matt colour.



Bild 39

[35] Align the tab of the washer (445, arrow) to the groove of the stub axle by turning the axle nut (446) and gently press the wheel hub unit.

[36] Push the complete hub unit centrally onto the stub axle.

[37] Screw on the axle nut; in this way the complete hub unit is mounted onto the stub axle.

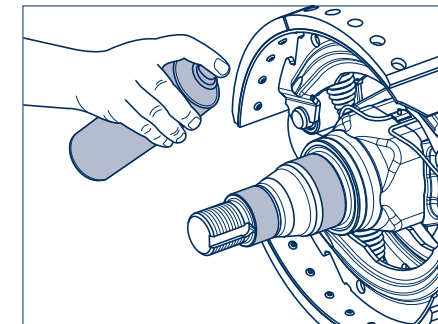
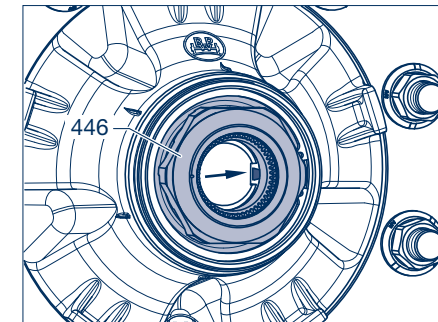

Picture 40

[38] Fasten axle nut using a hexagon socket spanner whilst rotating the ECO hub unit. It should take several turns until the clutch on the axle nut slips (do not use an impact driver).

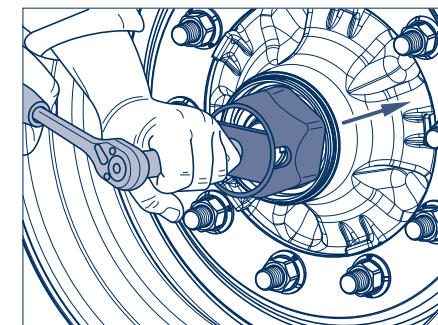

Picture 41

7 Changing the brake lining

- [39] Fit the retaining key (449) in the groove between the axle stub and the nut (446) (do not reset the axle nut).
- [40] For production date April 2000 onwards, insert the hooked spring ring (448) behind the edge of the axle nut or, up to March 2000, into the thread on the axle stub.

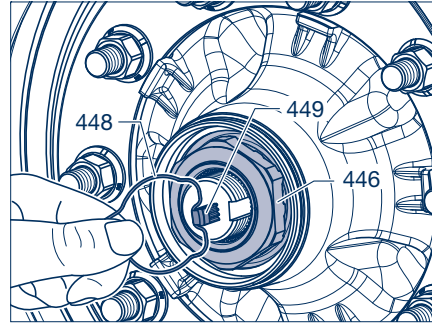

Picture 42

- [41] Insert a new O-ring (459) into the groove in the wheel hub (435, arrow). (The O-ring is not required for axles with ECO Plus Unit.)

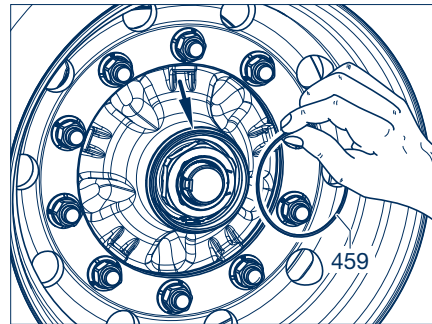

Picture 43

- [42] Cover the hub cap (460) in the area of the O-ring contact surface (only for ECO Plus 3) and the thread with a thin coat of BPW special longlife grease ECO-Li^{Plus}.

- [43] Screw the hub cap (460) onto the wheel hub (435) and tighten with the prescribed torque.

Tightening torques:

Hub cap ECO Plus 3	SW 110	350 Nm
Hub cap ECO Plus	SW 110	800 Nm



Adjust brake.

Adjust slack adjuster (280) using adjusting hexagon to a play of 10 - 12% of the connected brake lever length. The automatic slack adjuster ECO-Master adjusts itself on actuation of the brake lever. Initial free play of the ECO-Master should be set manually.

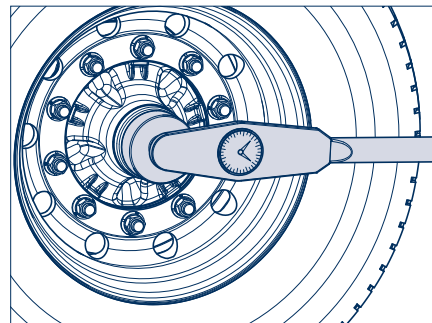

Picture 44

ECO Plus 2 Unit:

- [34] Clean the bearing seats of the axle stub (metal must be bright, dry and free from grease). Spray with **BPW ECO Assembly and Protection Spray**. Allow to dry for about 10 minutes until the film changes to a marked matt colour.

The threaded hole in the axle stub is only allowed to be lubricated with ECO-Li^{Plus}.



Caution!
Do not apply too much grease!
It is necessary to make sure that the axle bolt can be completely bolted into the axle stub.

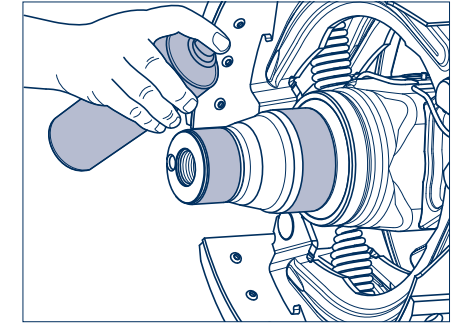

Picture 45

- [35] Guide the toothed lock washer (446/1) into the hole in the axle stub. The position of the pin can be seen by the indented BPW logo in the recess of the axle bolt (446/2).

- [36] Fasten axle bolt (46 mm) whilst rotating the ECO hub unit. It should take several turns until the clutch on the axle bolt slips. (Do not turn back the axle bolt.)



Important!
Do not use an impact driver.

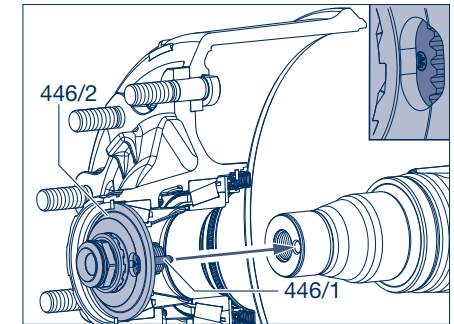

Picture 46

- [37] Insert the retaining key (449) into the recess in the axle bolt (446/2) and the gearing of the toothed lock washer (446/1). (Do not turn back the axle bolt.)

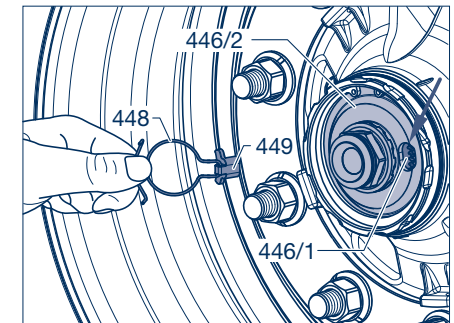

Picture 47



Warning!
New brake linings only have maximum effect after a few braking actions.

7 Changing the brake lining

- [38] Insert the hooked spring ring (448) into the groove of the hexagon profile of the axle bolt (446/2).

Repair guide!
Make sure that the clasped spring ring assembly is correctly seated in the annular groove of the axle bolt.

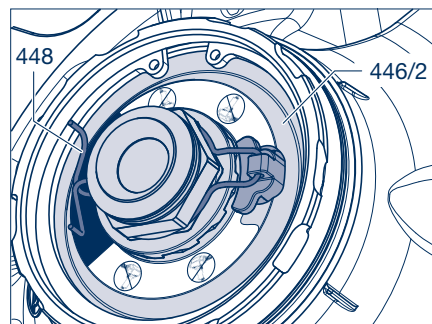

Picture 48

- [39] Insert a new O-ring (459) into the groove in the wheel hub (435).

- [40] Apply a thin layer of BPW ECO-Li^{plus} special long-life grease to the cap (460) in the area of the O-ring contact surface and the bayonet fitting.

- [41] Screw on the cap with a 120 mm cap spanner.

Important!
Do not use an impact driver - bayonet lock.

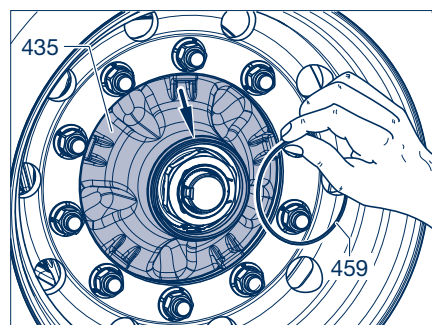

Picture 49

- [42] Push on the cap, see position 1. **Press on the cap** and turn it by approx. 30° in a clockwise direction to lock it in place. A tight seat is provided when position 2 is reached.

- Adjust brake.**
Adjust slack adjuster (280) using adjusting hexagon to a play of 10 - 12% of the connected brake lever length. The automatic slack adjuster ECO-Master adjusts itself on actuation of the brake lever. Initial free play of the ECO-Master should be set manually.

Warning!
New brake linings only have maximum effect after a few braking actions.

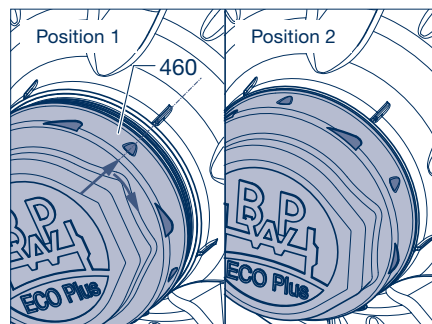

Picture 50

ECO Unit:

- [34] Clean the bearing seats of the axle stub (metal must be bright, dry and free from grease). Spray with **BPW ECO Assembly and Protection Spray**. Allow to dry for about 10 minutes until the film changes to a marked matt colour.

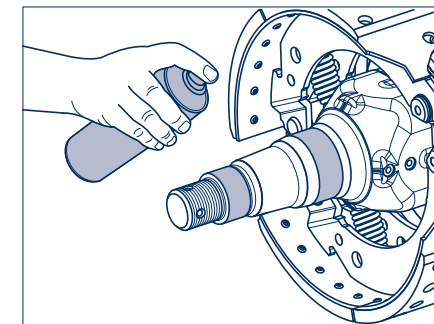

Picture 51

- [35] Align the tab of the washer (445, arrow) to the groove of the stub axle by turning the axle nut (446) and gently press the wheel hub unit.

- [36] Push the complete hub unit centrally onto the stub axle.

- [37] Screw on the axle nut. In this way the complete hub unit is mounted onto the stub axle.

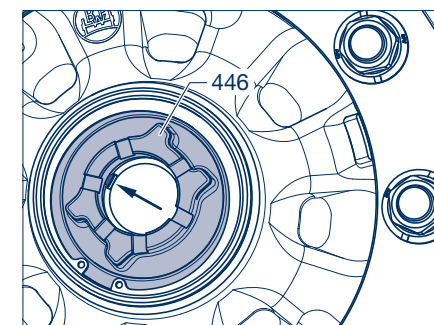

Picture 52

- [38] Fasten axle nut using a torque wrench whilst rotating the ECO hub unit. It should take several turns until the tightening torque has reached 150 Nm. Turn the nut back until the next securing position is aligned (max. 15°).

- The next locking hole is reached by turning back the asymmetrical axle nut by a maximum of 15°.

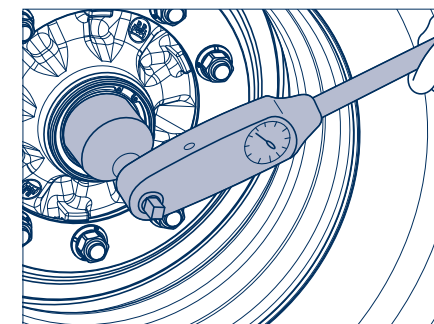

Picture 53

7 Changing the brake lining

- [39] Push in retention pin (447). Insert hook spring ring (448) with hook (arrow) near pin and push into the annular groove of the axle nut (446).

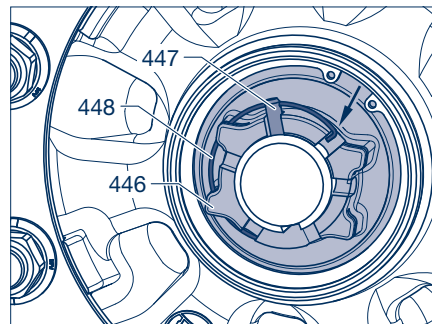

Picture 54

- [40] Smear the threads of the hub cap (460) all round with BPW special longlife grease ECO-Li^{Plus}.

- [41] Screw hub cap onto wheel hub. Tightening torque 800 Nm.



Adjust brake.

Adjust manual slack adjuster (280) using adjusting hexagon to a play of 10 - 12% of the connected brake lever length.

On page 123 the adjustment of the automatic slack adjuster ECO-Master is described.

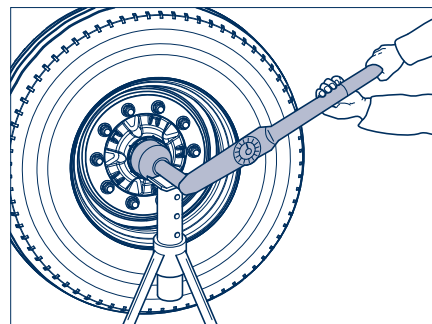

Picture 55



Warning!

New brake linings only have maximum effect after a few braking actions.

Conventional hub bearing:

- [34] Clean the bearing seats of the axle stub (metal must be bright, dry and free from grease).

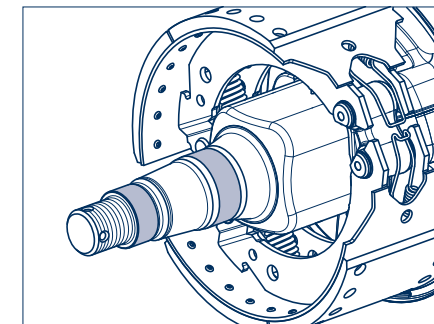

Picture 56

- [35] Series H / K:
Push thrust washer (420) and new grease seals (422, 423) onto the axle stub.

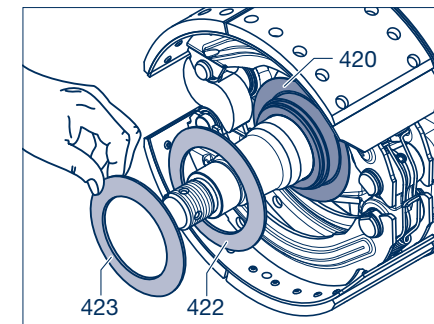

Picture 57

Series N:

Push the thrust washer (420) and shaft seal (422), onto the axle stub with the closed side to the stop ring.

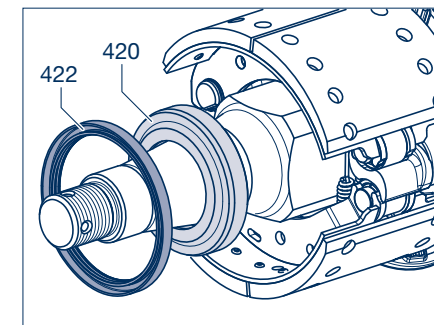

Picture 58

7 Changing the brake lining



Repair guide!

Do not mix up bearing races and outer bearing rings.

- [36] Clean and inspect taper roller bearing (430) thoroughly.
- [37] Heat the bearing inner race (with rollers and cage) correctly to about 80°C and push on up to the stop against the thrust washer (420).
Work BPW special longlife grease ECO-Li^{Plus} into the spaces between the conical rollers and the race. Use only the maximum amount of grease, see page 35.
- [38] Apply the remainder to outer bearing race of the hub.
- [39] Slide on the complete hub and brake drum assembly concentrically. When the hub is fitted, the ABS sensor (570) is pushed back to the correct position by the exciter ring (560). For this reason, do not cant hub.
- [40] Insert outer taper roller bearing (441).

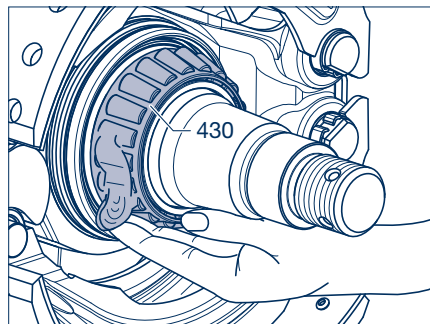

Picture 59

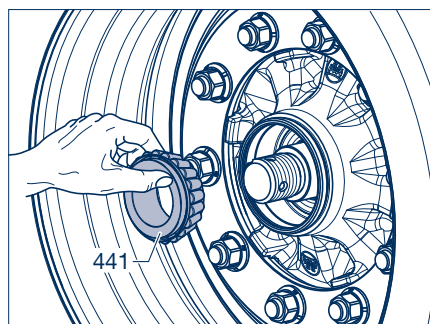

Picture 60



Repair guide!

From January 1995, BPW axle beams will be converted to ECO axle stubs.

These differ from the conventional axle stubs by a keyway in the thread area (arrow).

A new axle nut (446) and in addition a washer (445) is used to fit the conventional bearing to ECO axle stubs.

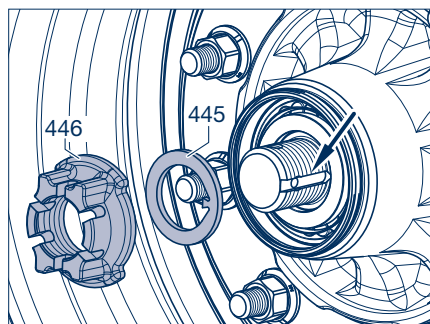

Picture 61

- [41] Screw on the axle nut (446) and fasten using a torque wrench and with the continuous turning of the wheel hub. It should take several turns until the tightening torque has reached the desired value.
Tightening torques:

Hub caps with BPW oval shape:

Up to an axle load of 5.5 tons = 70 Nm,
from 6 to 18 tons axle load = 150 Nm,

Hub caps with octagonal shape:

from 16 to 30 tons axle load = 350 Nm

If a normal axle nut spanner is used (vehicle tool kit), tighten the axle nut until the wheel bearing race drags slightly.

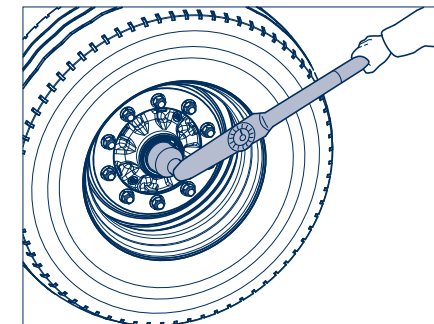

Picture 62

- [42] Unscrew axle nut to next hole or, if the axle nut is already positioned opposite a hole, turn back to the one before (max. 30°).

- [43] Axle nut (446) secured with a split pin (447).

-  For 16 - 18 t axles with BPW oval shape hub cap, a new O-ring must be fitted on reassembly.

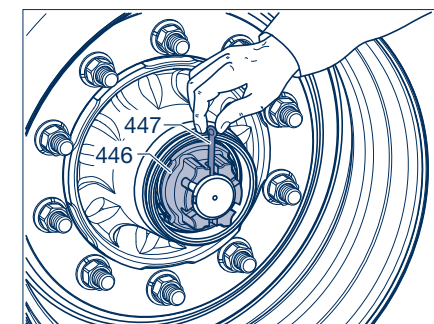

Picture 63

- [44] Fill the hub cap (460) with BPW special longlife grease ECO-Li^{Plus}.

-  Comply with total grease quantity, see page 35.

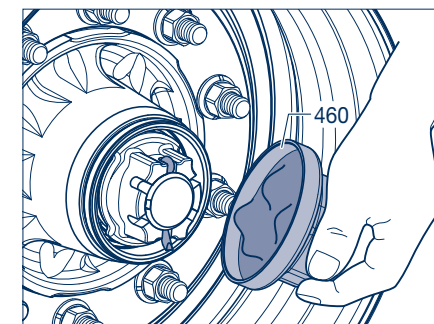

Picture 64

7 Changing the brake lining

- [45] Grease thread of hub cap (460) all round with BPW ECO-Li^{Plus} and screw on.

Tightening torques for hub caps:

Thread pitch 2 mm (oval shape)

Hub cap (inner thread)	500 Nm
Hub cap (outer thread)	800 Nm
Alloy hub cap	350 Nm

Thread pitch 3 mm

Hub cap (octagonal shaped)	700 Nm
----------------------------	--------



Adjust brake.

Adjust slack adjuster (280) using adjusting hexagon to a play of 10 - 12 % of the connected brake lever length. The automatic slack adjuster ECO-Master adjusts itself on actuation of the brake lever. Initial free play of the ECO-Master should be set manually.



Warning!

New brake linings only have maximum effect after a few braking actions.

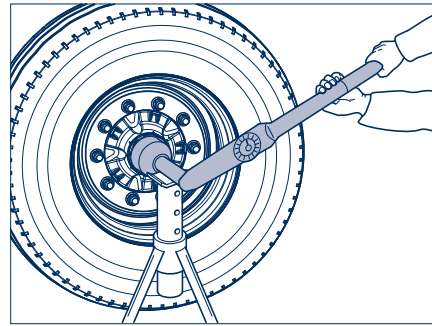

Picture 65

7.7 Conversion to brake with split roller (BPW 95 Brake)

Brakes of the former version should be changed over to new brake technology.

High degree of safety

Short response time and a consistent braking effect throughout the entire life of the lining thanks to the permanently lubricated brake rollers.

Reduced weight

Weight-optimized design with fewer wear parts.

Easy to change brake linings

Fast and easy brake shoe replacement.

Position springs

The position springs ensure the brake shoes are firmly and securely seated on the locking rings (C-clips).

Brake return springs

The brake return spring is hooked into lugs that are formed on the brake shoes.

Same brake components on all axles of the corresponding series.

The technical specifications of the brake remain unchanged. Consequently existing EC test certificates remain valid.

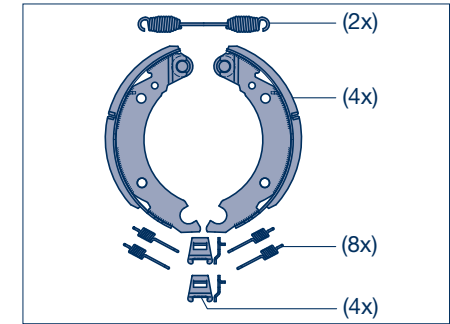

Picture 66

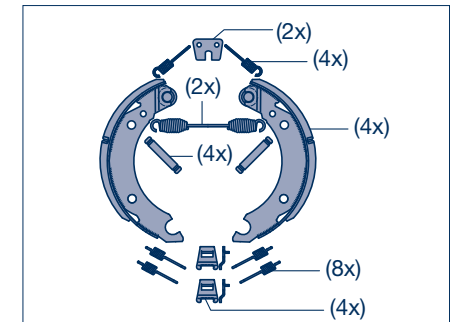

Picture 67

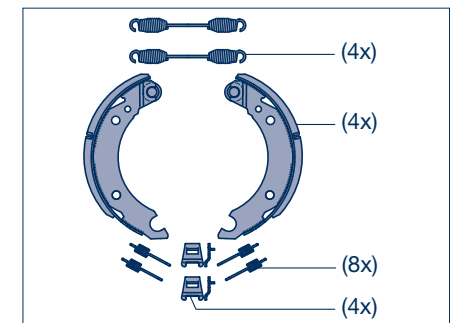

Picture 68

8 Dismantling and assembling the hub unit

8.1 ECO Plus 3 Unit



Note:
Opening the ECO Plus 3 Unit before the end of the warranty period invalidates the ECO Plus warranty (see ECO Plus warranty documents).

- [1] Removing and installing the complete ECO Plus 3 unit, see chapter 7.
- [2] To remove the outer roller bearing (441), remove circlip (438) and axle nut (446) from the wheel hub (435).

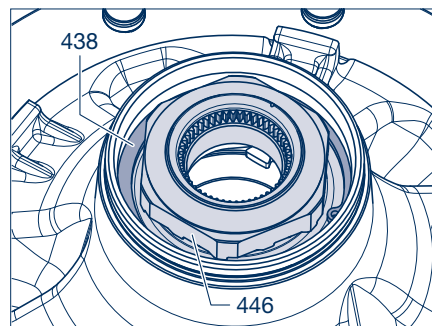

Picture 1

- [3] Remove lug washer (445) and roller bearing (441).



Repair guide!
Mark both the hub and bearing to ensure correct positioning during re-assembly. It is essential for the bearing inner rings with rollers to be re-inserted in the same hubs.

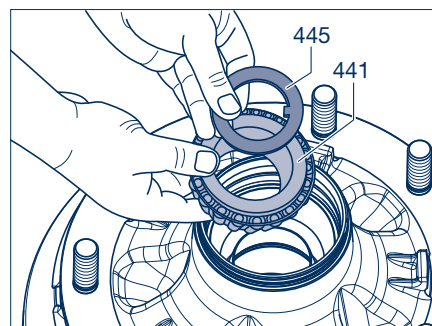

Picture 2

- [4] Lever the exciter ring (560) from the wheel hub (435). In doing so, avoid damage to the base of the wheel hub.

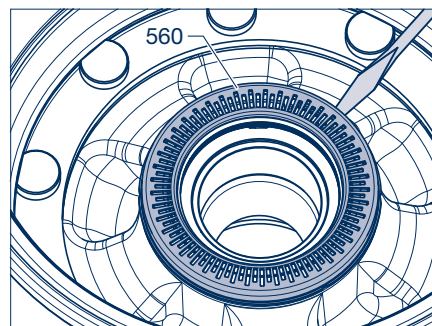

Picture 3

- [5] To remove the inner roller bearing (430), remove circlip (437) from the wheel hub (435).

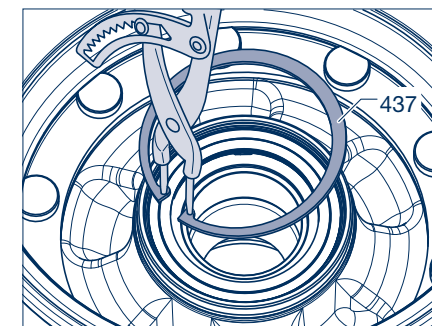

Picture 4

- [6] Release the radial lip seal (422) from the bearing race with a screwdriver.

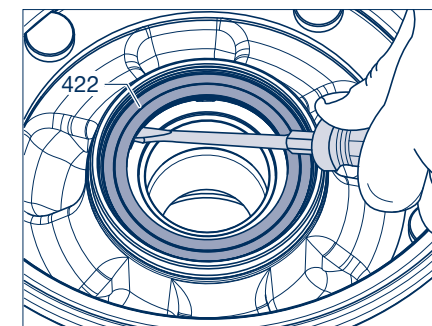

Picture 5

- [7] Remove the radial lip seal (422).

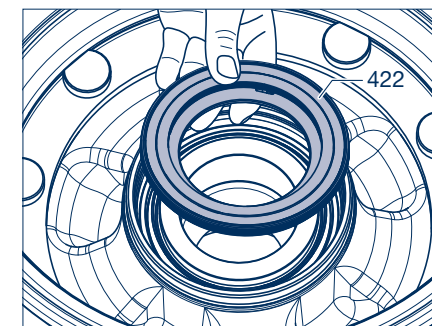

Picture 6

8 Dismantling and assembling the hub unit

- [8] Remove the inner tapered roller bearing (430).
- [9] Remove both tapered roller bearings (430, 441), clean thoroughly and check for wear. Renew if necessary.

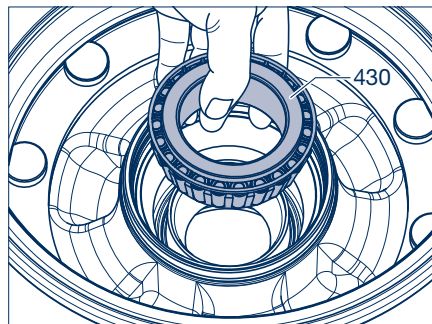

Picture 7

- [12] Take the grease cartridge (432) out of the wheel hub (435).

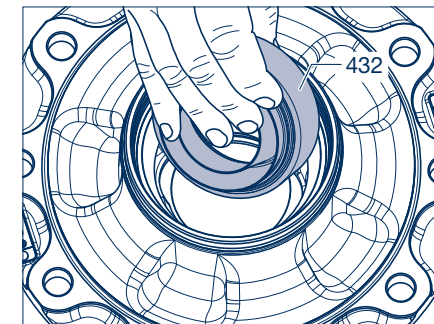

Picture 10



Note:
We recommend removing the brake drum (380) if it is necessary to renew the bearing cups.

- [10] Drive the wheel studs (472) out of the removed hub/brake drum unit (do not damage the threads of the wheel studs).

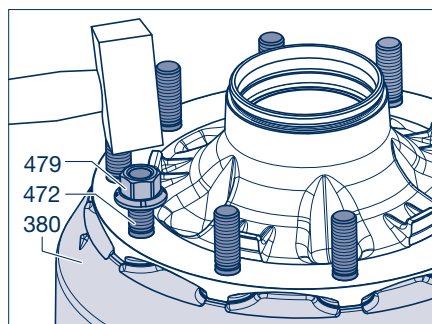

Picture 8

- [13] Drive the bearing outer rings out of the wheel hub (435).

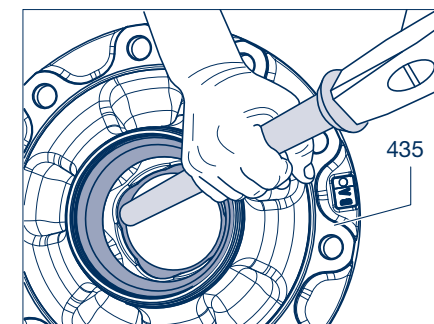

Picture 11

- [11] Lever the grease cartridge (432) out of the bearing cavity.

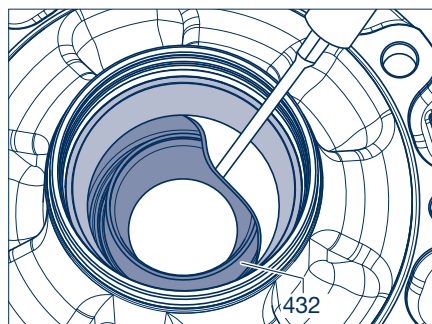

Picture 9

- [14] Centre the new bearing outer races and insert them in the wheel hub (435). Install using a press (min. 6 t) and the BPW insertion tools 15.011.20052 and 15.013.20052.



Repair guide!
Make sure the bearing cups are correctly seated in the wheel hub.

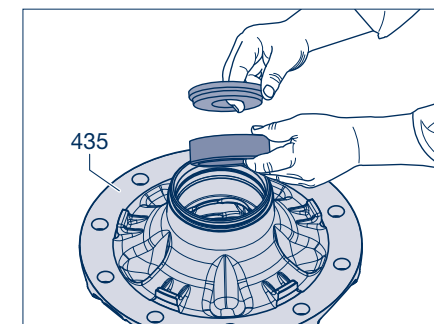

Picture 12

8 Dismantling and assembling the hub unit

- [15] Insert the seal (432/bearing intermediate piece) between the installed bearing outer rings.

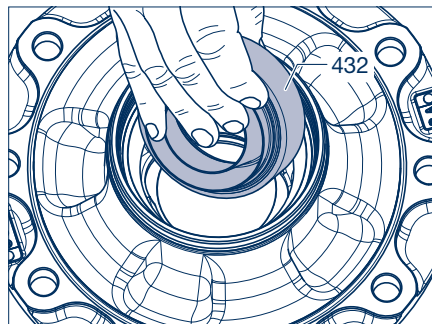

Picture 13

- [16] Grease both tapered roller bearings with BPW special longlife grease ECO-Li^{Plus}. Note the total grease quantity (tapered roller bearing 33318 - 170 g and 33213 - 120 g).



Note:
We recommend greasing the bearings with BPW grease applicators 99.00.000.9.55.

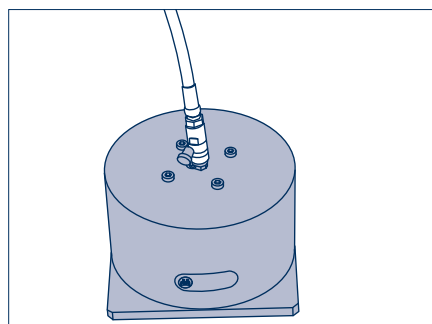

Picture 14

- [17] Fit inner roller bearing (430) into wheel hub (435).



Repair guide!
Do not mix up bearing cage and outer bearing rings.

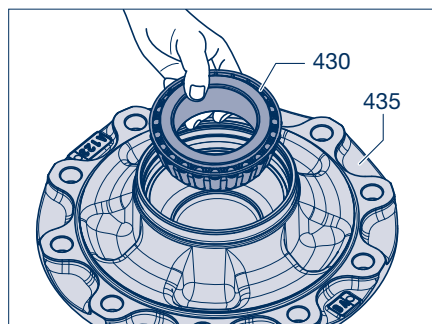

Picture 15

- [18] Insert the lip seal (422) into the wheel hub (435) with the 3 locating tangs facing the bearing (430).

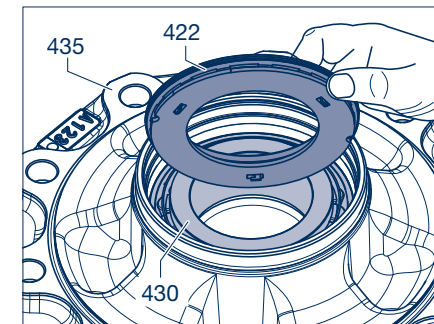

Picture 16

- [19] Place the hub cap (460) onto the seal (422) and knock it in with light hammer blows until the seal is in contact with the bearing.

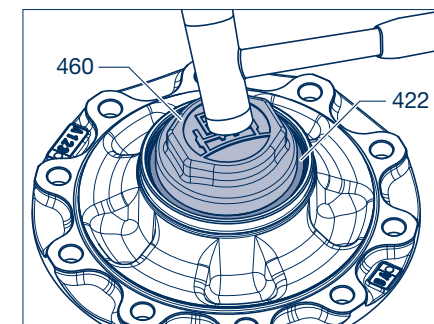

Picture 17

- [20] Fit circlip (437) into the groove of the wheel hub (435).

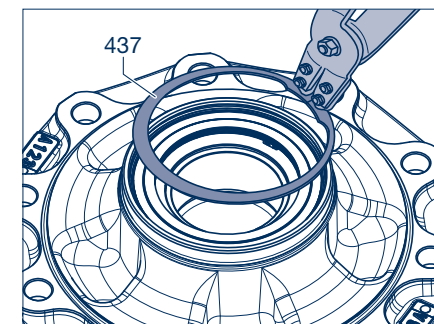

Picture 18

8 Dismantling and assembling the hub unit

- [21] Place the brake drum (380) onto the wheel hub (435). Insert the wheel studs (472) as far as possible into the hub.



Repair guide!
Make sure the wheel stud head is correctly seated on the brake drum.

A corrosion inhibitor may be needed to guide prior to fitting the brake drum.

- [22] The flattened side of the wheel stud head must be in contact with the brake drum collar (anti-rotation lock).

- [23] Knock in the wheel stud as far as the stop.

- [24] Clean the stop surfaces for the exciter ring (560) (free from dirt, paint, etc.).

- [25] Fit the new exciter ring and fasten with the assembly tool (BPW No. 16.038.22953) until it is in contact.

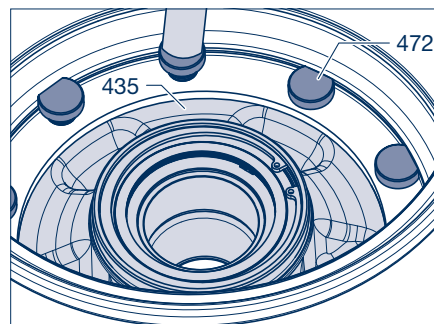

Picture 19

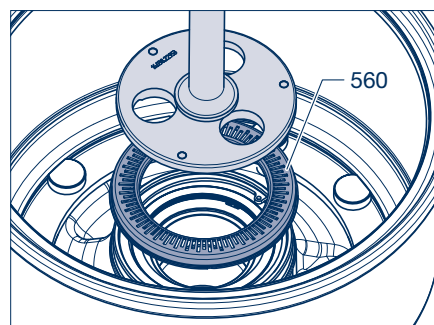

Picture 20

- [26] Fit outer roller bearing (441) into wheel hub (435).

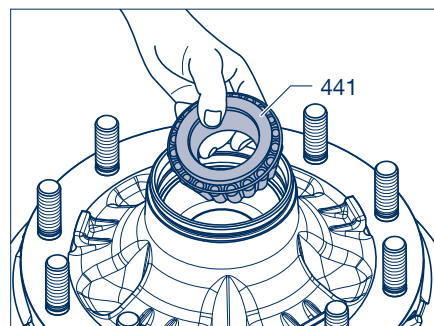

Picture 21

- [27] Place the keyed thrust washer (445) (with the embossed BPW and code number) next to the tapered roller bearing (441).

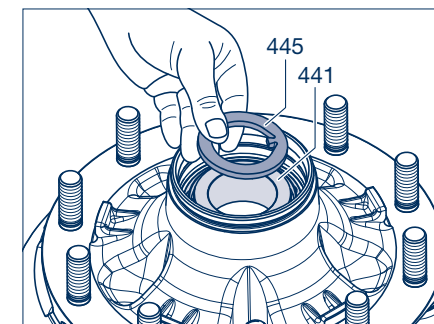

Picture 22

- [28] Fit circlip (438) with axle nut (446) into the groove of the wheel hub.

Mounting the complete ECO Unit (434), see from page 61.

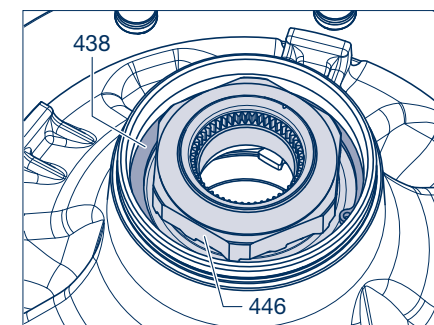

Picture 23

8 Dismantling and assembling the hub unit

8.2 ECO Plus 2 Unit



Note:
Opening the ECO Plus 2 Unit before the end of the warranty period invalidates the ECO Plus warranty (see ECO Plus warranty documents).

- [1] Removing and installing the complete ECO Plus 2 unit, see chapter 7.
- [2] Remove the circlip (438) from the wheel hub (435) to remove the outer tapered roller bearing (441).

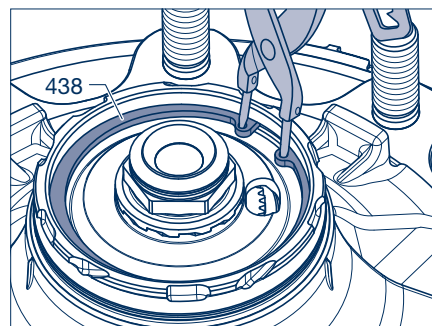

Picture 24

- [3] Remove the axle bolt with toothed washer and integrated pin (446).

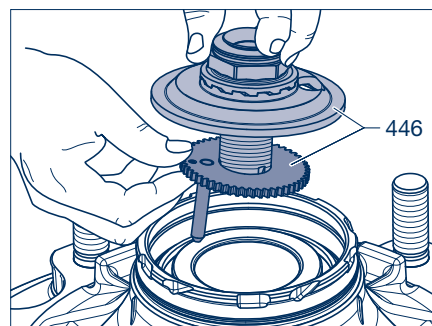

Picture 25

- [4] Take the tapered roller bearing (441) out of the wheel hub.



Repair guide!
Mark both the hub and bearing to ensure correct positioning during re-assembly. It is essential for the bearing inner races and rollers to be re-inserted in the same hubs.

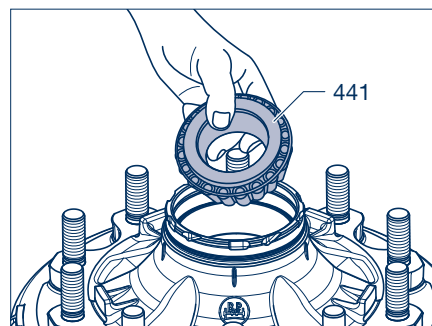

Picture 26

- [5] Position assembly tool BPW no. 16.020.22953 on the outer circumference of the exciter ring (560) and press it down. Turn it anticlockwise at the same time to release it.



Repair guide!
Do not bend or damage the exciter ring when removing it.

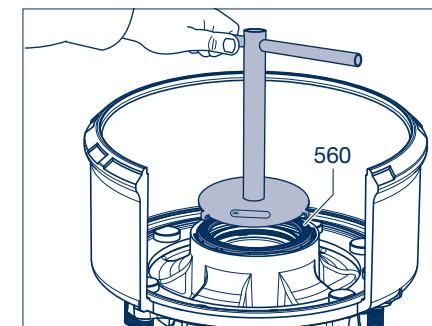

Picture 27



Repair guide!
When removing the exciter ring with a screwdriver, for example, make sure the 3 tabs on the outer circumference are pressed downwards. Remove the exciter ring by turning it anticlockwise. The tabs will have been bent during the removal and it will no longer be possible to achieve the preload forces on reinstallation. Therefore, the exciter ring must be renewed.

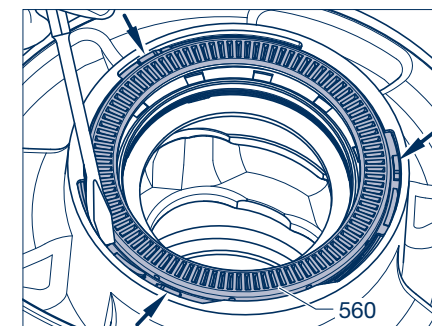

Picture 28

- [6] To remove the inner roller bearing (430), remove circlip (437) from the wheel hub.

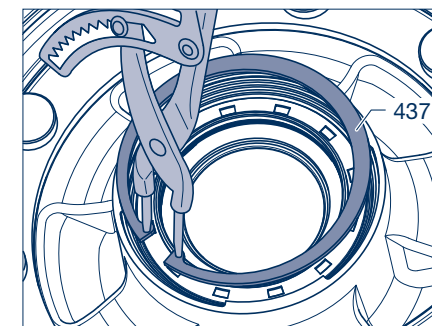

Picture 29

8 Dismantling and assembling the hub unit

- [7] Release the oil seal (422) from the bearing race with a screwdriver.

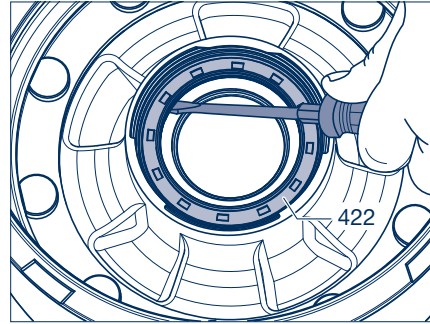

Picture 30

- [8] Remove the oil seal (422).

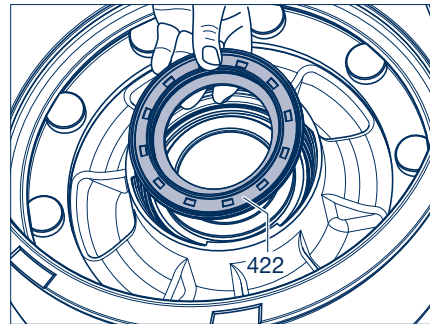

Picture 31

- [9] Remove the inner tapered roller bearing (430).
 [10] Remove both tapered roller bearings (430, 441), clean thoroughly and check for wear. Renew if necessary.

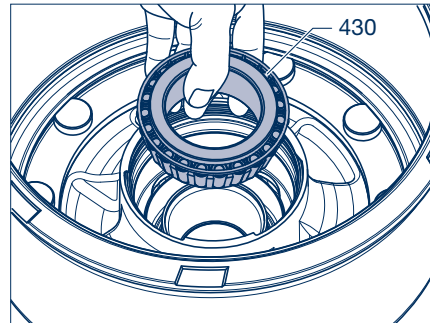

Picture 32



Note:
 We recommend removing the brake drum (380) if it is necessary to renew the bearing cups.

- [11] Drive the wheel studs (472) out of the removed hub/brake drum unit (do not damage the threads of the wheel studs).

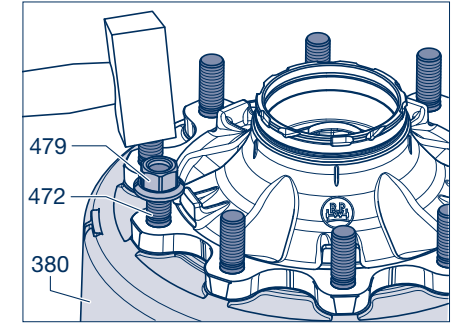

Picture 33

- [12] Lever the grease cartridge (432) out of the bearing cavity.

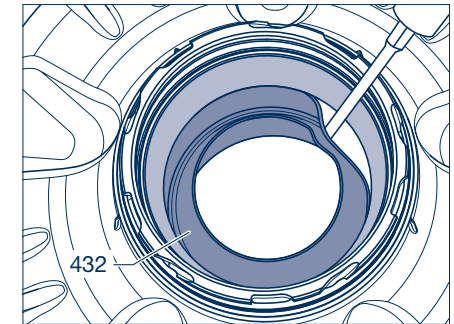

Picture 34

- [13] Take the grease cartridge (432) out of the wheel hub.

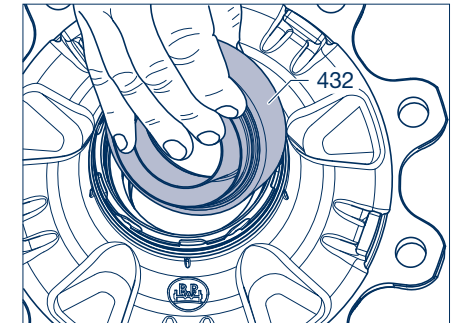

Picture 35

8 Dismantling and assembling the hub unit

- [14] Drive the bearing outer races out of the wheel hub (435).

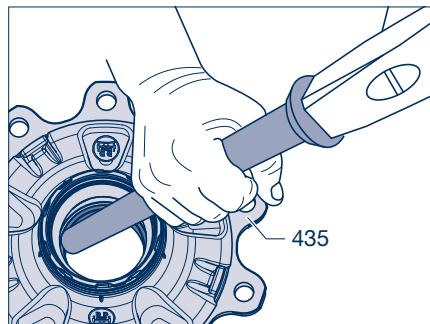

Picture 36

- [15] Centre the new bearing outer races and insert them in the wheel hub (435). Install using a press (min. 6 t) and the BPW insertion tools 15.011.20052 and 15.013.20052.

Repair guide!
Make sure the bearing cups are correctly seated in the wheel hub.

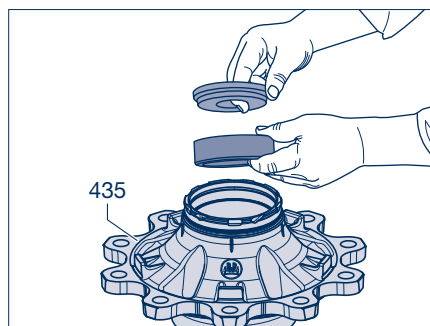

Picture 37

- [16] Clean the grease cartridge (432, bearing intermediate piece) and insert between the mounted bearing outer races.

- [17] Fill both sides of the grease cartridge with BPW ECO-Li^{Plus} grease.

Repair guide!
It is important to ensure that it is filled without any air inclusions or cavities.

When BPW grease applicators are used, there is no need to fill the grease cartridge.

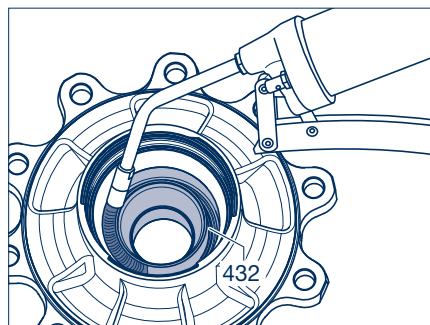

Picture 38

- [18] Apply a ring-shaped bead of grease to the running surfaces of the bearing outer races.

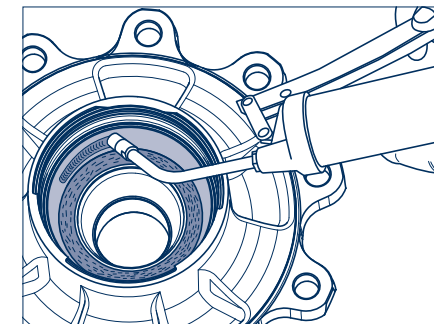

Picture 39

- [19] Fit inner roller bearing (430) into wheel hub (435).

Repair guide!
Do not mix up bearing races and outer bearing rings.

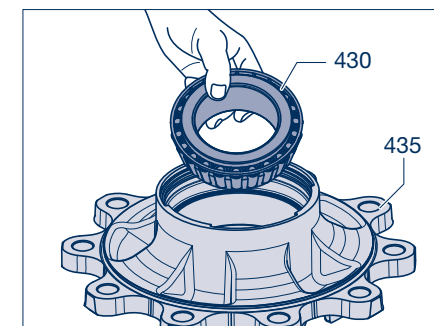

Picture 40

- [20] Insert the seal (422) into the wheel hub (435) with the 3 locating tangs facing the bearing (430).

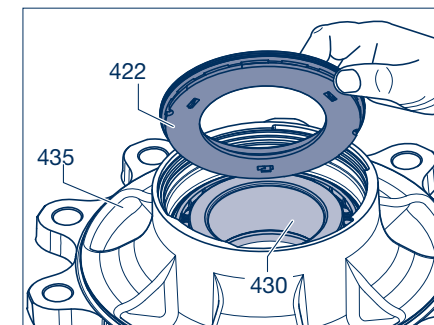

Picture 41

8 Dismantling and assembling the hub unit

- [21] Place the hub cap (460) onto the seal (422) and knock it in with light hammer blows until the seal is in contact with the bearing.

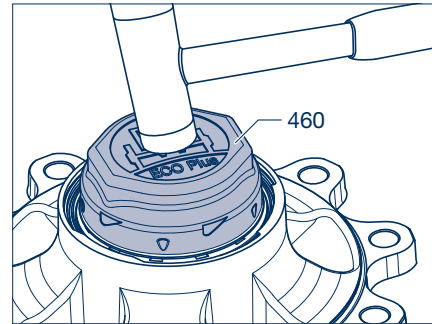

Picture 42

- [22] Fit circlip (437) into the groove of the wheel hub (435).

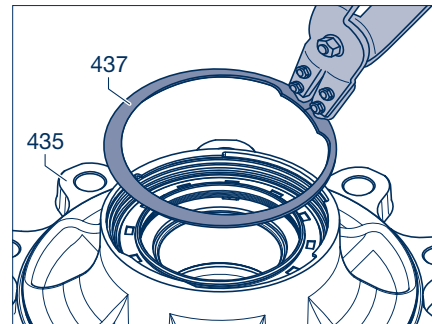

Picture 43

- [23] Place the brake drum (380) onto the wheel hub (435). Insert the wheel studs (472) as far as possible into the hub.



Repair guide!
Make sure the wheel stud head is correctly seated on the brake drum.

A corrosion inhibitor may be needed to guide prior to fitting the brake drum.

- [24] The flattened side of the wheel stud head must be in contact with the brake drum collar (anti-rotation lock).

- [25] Knock in the wheel stud as far as the stop.

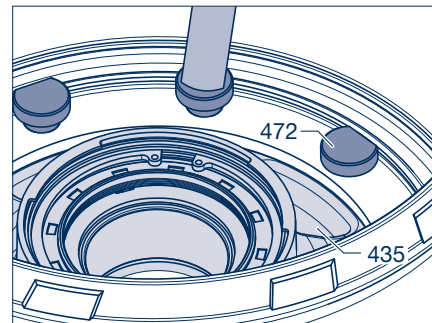

Picture 44

- [26] Use a new exciter ring (560)! Grease the exciter ring groove and bayonet locks on the exciter ring on both sides.

- [27] Insert the exciter ring in the correct position. The rotational stops on the exciter ring must contact right-angled stop surfaces in the hub.

- [28] Use a blunt object (e.g. screwdriver) to strike the exciter ring lightly behind the stop cams so as to rotate it clockwise as far as the stop (see also page 81).



Repair guide!

Do not use impact tools to fit the exciter ring. Make sure there are no signs of damage on the teeth of exciter ring.

To avoid mistakes when mounting, we recommend using the BPW assembly tool 16.020.22953 when renewing the exciter ring.

- [29] Press the assembly tool down on the outer circumference whilst turning clockwise and anticlockwise to release or fasten the exciter ring.

- [30] Completely fill the exterior grease chamber of the grease cartridge (432) with BPW special longlife grease ECO-Li^{plus}.



Repair guide!

It is important to ensure that it is filled without any air inclusions or cavities.

When BPW grease applicators are used, there is no need to fill the grease cartridge (432).

- [31] Fit outer roller bearing (441) into wheel hub.

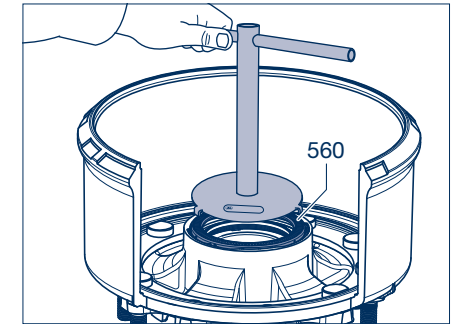

Picture 45

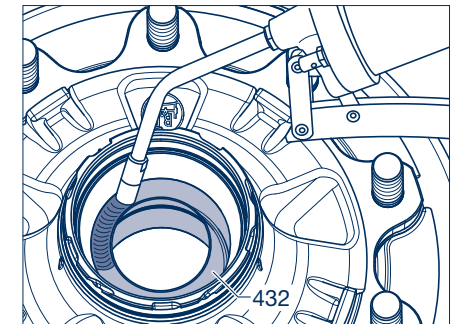

Picture 46

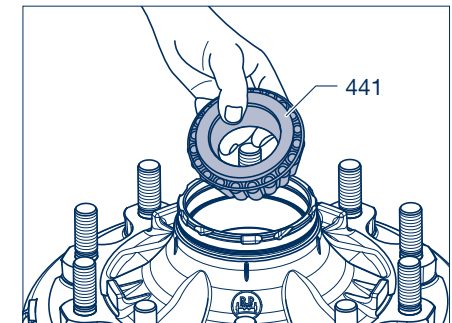

Picture 47

8 Dismantling and assembling the hub unit

- [32] Push the toothed washer (446/2) with integrated pin onto the axle bolt (446/1) and place on the tapered roller bearing (441).

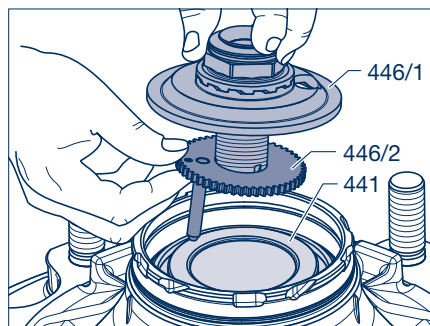

Picture 48

- [33] Secure the axle bolt (446) in the wheel hub with a locking ring (438).

Mounting the complete wheel hub, see from page 63.

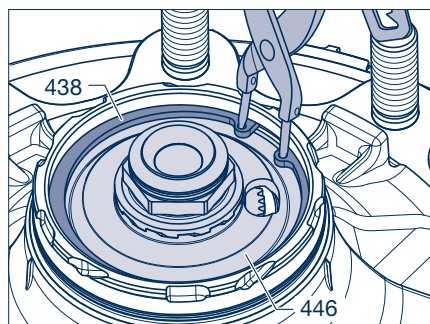

Picture 49

8.3 ECO^{Plus} Unit

- [1] Dismantling and refitting the complete wheel hub bearing, see chapter 7.
- [2] To remove the outer roller bearing (441), remove circlip (438) and axle nut (446) from the wheel hub (435).

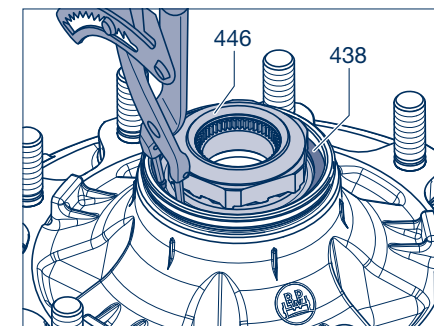

Picture 50

- [3] Remove lug washer (445) and roller bearing (441).



Repair guide!

Mark both the hub and bearing to ensure correct positioning during re-assembly. It is essential for the bearing inner races and rollers to be re-inserted in the same hubs.

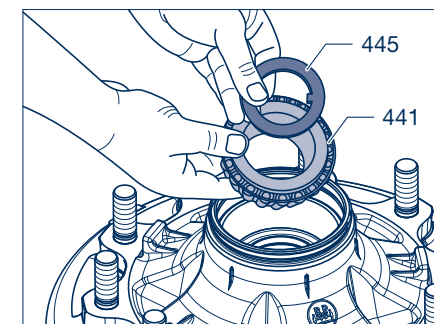

Picture 51

- [4] If the ABS sheet metal exciter ring (560) is fitted, remove it from the wheel hub. Cast exciter rings should not be removed!

8 - 9 t ECO^{Plus}:

Position assembly tool BPW no. 16.020.22953 on the outer circumference of the exciter ring and press it down. Turn it anticlockwise at the same time to release it.



Repair guide!

Do not bend or damage the exciter ring when removing it.

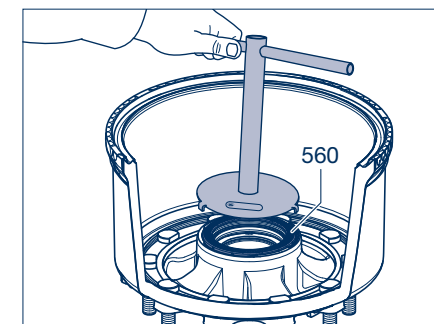

Picture 52

8 Dismantling and assembling the hub unit



Repair guide!

When removing the exciter ring from ECO^{Plus} 8 - 9 t axles with a screwdriver, for example, make sure the 3 tabs on the outer circumference are pressed downwards.

Remove the exciter ring by turning it anticlockwise.

The tabs will have been bent during the removal and it will no longer be possible to achieve the preload forces on reinstallation. Therefore, the exciter ring must be renewed.

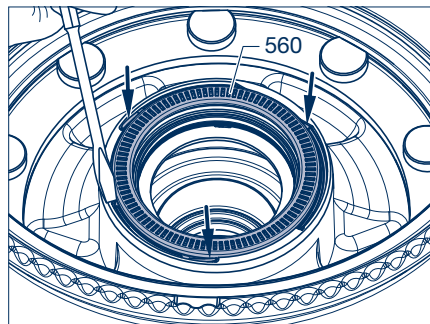

Picture 53

Series K 10 - 12 t:

Gently pull on the clamps at the outer edge of the pole wheel (560) and remove the wheel from the wheel hub



Repair guide!

Do not bend or damage the exciter ring when removing it.

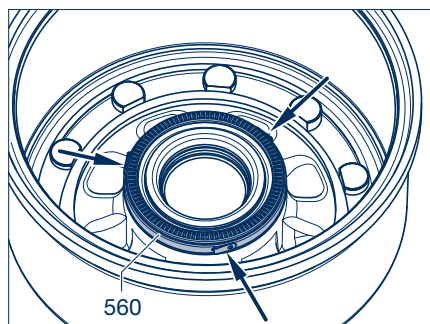

Picture 54

- [5] If fitted, pry the coarse dirt seal (428) from the wheel hub (435) and from the shaft seal (422).

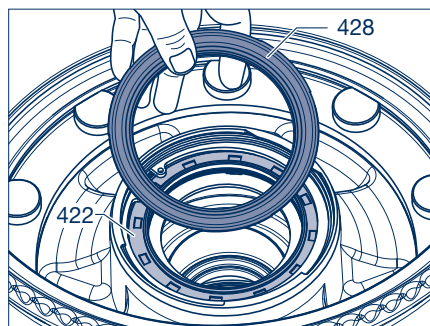

Picture 55

- [6] To remove the inner roller bearing (430), remove circlip (437) from the wheel hub (435).

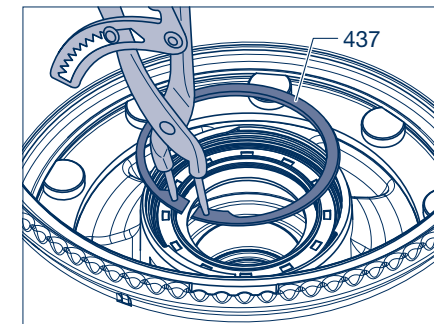

Picture 56

- [7] ECO^{Plus} bearings 8 - 9 t:
Depending on the design of the shaft seal or ECO^{Seal} seal (422) fitted.

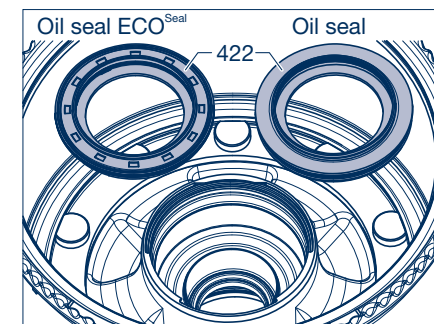

Picture 57

- ECO^{Plus} bearings 10 - 12 t:
Thrust ring (421) with oil seal (422) or ECO^{Seal} seal and O-ring (424).

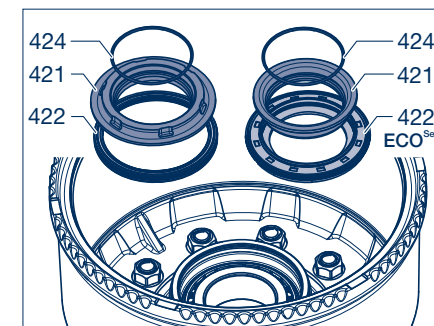

Picture 58

8 Dismantling and assembling the hub unit

- [8] Remove the inner tapered roller bearing (430) and then the seal (432, bearing intermediate piece).
- [9] Remove both tapered roller bearings (430, 441), clean thoroughly and check for wear. Renew if necessary.

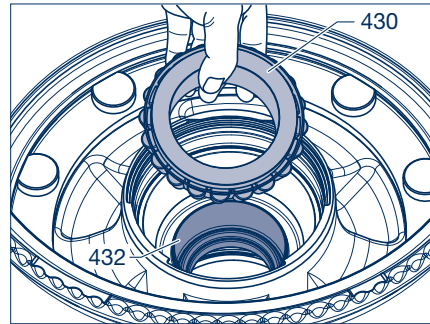

Picture 59

- [13] Fit the thrust washer (440) with the curved side facing the hub (435).

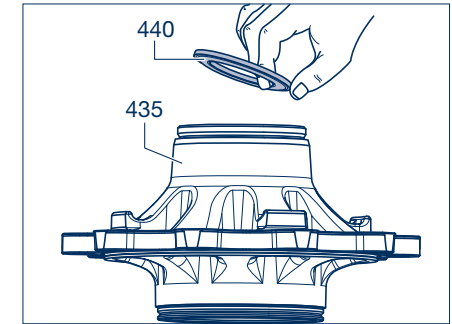

Picture 62



Note:
We recommend removing the brake drum (380) if it is necessary to renew the bearing cups.

- [10] Drive the wheel studs (472) out of the removed hub/brake drum unit (do not damage the threads of the wheel studs).

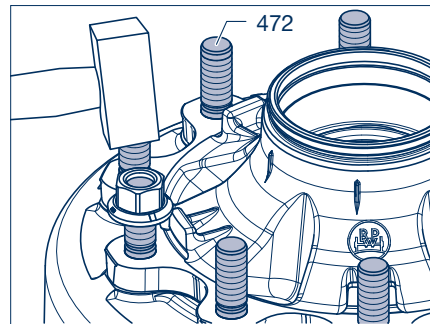

Picture 60

- [14] Insert the new dust cover (431) with the curved side facing the hub (435).

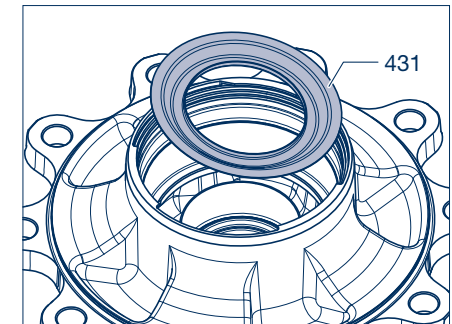

Picture 63

Removing the bearing cups

- [11] Drive the bearing outer races (together with the race (423) on ECO^{plus} bearings 10 - 12 t before 05/2005) out of the wheel hub (435).
- [12] Remove the dust cover (431) from the wheel hub.

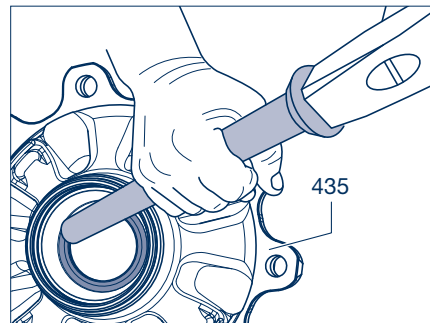

Picture 61

Installing the bearing cups

- [15] Centre the bearing outer races and insert them in the wheel hub. Install using a press (min. 6 t) and the BPW insertion tools 15.011.20052 and 15.013.20052.



Repair guide!
Make sure the bearing cups are correctly seated in the wheel hub.

- [16] Insert the seal (432, bearing intermediate piece) between the installed bearing outer races.

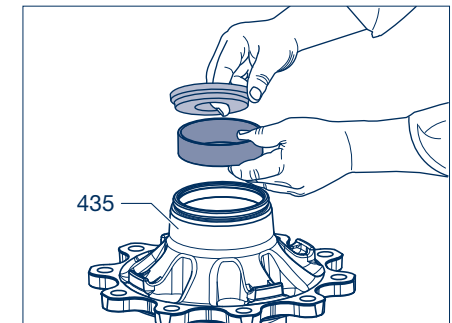

Picture 64

8 Dismantling and assembling the hub unit

- [17] Take a new race (423) and prepare the BPW inserti-
on tools.
16.020.22111 for race 8 - 9 t (before 09/2004)
16.014.22111 for race 10 - 12 t (before 05/2005)
Press the race centrally into the old wheel hub (435).



Repair guide!

ECO^{Plus} bearings (8 - 9 t before 09/2004):

The existing seal wear ring remains in the wheel hub, continues to be used and must not be renewed, until the new ECO^{Seal} seal is inserted.

ECO^{Plus} bearings (10 - 12 t before 05/2005):

The old version of the seal with the seal wear ring must continue to be inserted in these bearings.

There is no longer a seal wear ring in all ECO^{Plus} bearings 8 - 9 t after 10/2004 and 10 - 12 t after 6/2005. Only the new ECO^{Seal} seal is inserted!

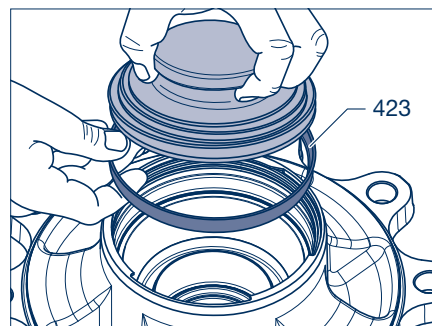

Picture 65

- [18] ECO^{Plus} 8 - 9 t bearings:
In ECO^{Plus} axles for axle loads 8 - 9 tonnes, the thrust washer is formed onto the axle stub. The oil seal is permanently attached to a stepped disc and has to be replaced as a complete unit.

The new generation ECO^{Seal} oil seals are configured as a cartridge seal and replace the former oil seal used in ECO^{Plus} bearings 8 - 9 t and 10 - 12 t after 06/2005.

ECO^{Plus} bearings 10 - 12 t before 05/2005 and ECO 8 - 12 t:

Press in the new oil seal (422) (with its open side facing upwards) as far as the stop against the thrust washer (421).

Apply BPW special longlife grease ECO-Li^{Plus} to the sealing lip.

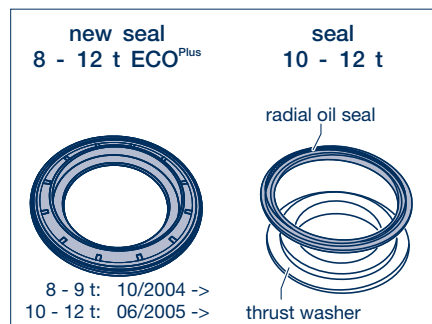

Picture 66

- [19] Grease both tapered roller bearings (430, 441) with BPW special longlife grease ECO-Li^{Plus}. Note the total grease quantity (tapered roller bearing 33318 - 170 g and 33213 - 120 g).



Note:

We recommend greasing the bearings with BPW grease applicators 99.00.000.9.54 / 99.00.000.9.55.

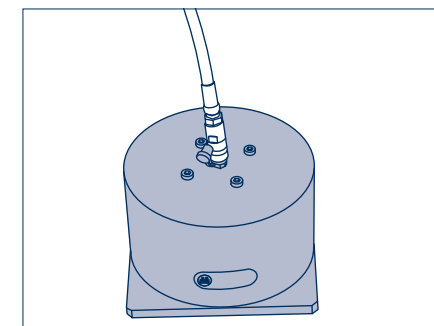

Picture 67

- [20] Fit inner roller bearing (430) into wheel hub (435).



Repair guide!

Do not mix up bearing races and outer bearing rings.

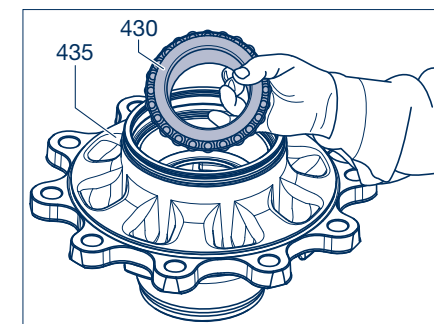

Picture 68

- [21a] ECO^{Plus} 8 - 9 t and 10 - 12 t bearings after 06/2005:

Apply a light coating of BPW special longlife grease ECO-Li^{Plus} to the outer rubber edge of the new cartridge seal (422).

- [22a] Insert the seal into the wheel hub (435) with the 3 locating tangs facing the bearing (430).

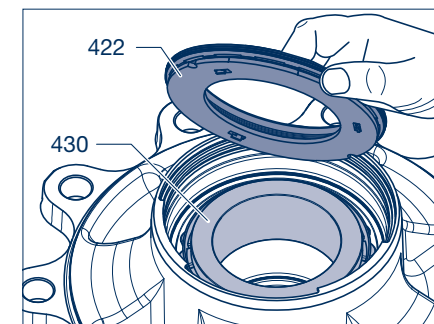

Picture 69

8 Dismantling and assembling the hub unit

[21b] ECO^{Plus} bearings 10 - 12 t before 05/2005:

Insert the O-ring (424) into the groove of the thrust washer (421).

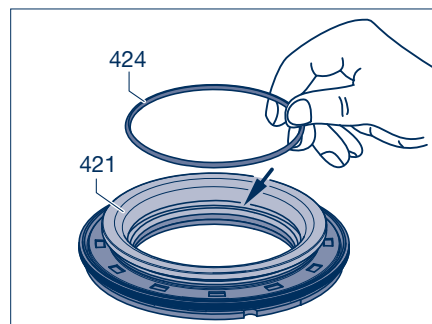

Picture 70

[22b] Insert the thrust washer (421) with oil seal (422) and O-ring (424) into the wheel hub (435).

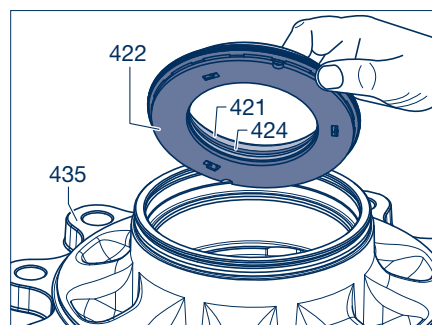

Picture 71

[23] Place the hub cap (460) onto the seal (422) and knock it in with light hammer blows until the seal is in contact with the bearing (430).

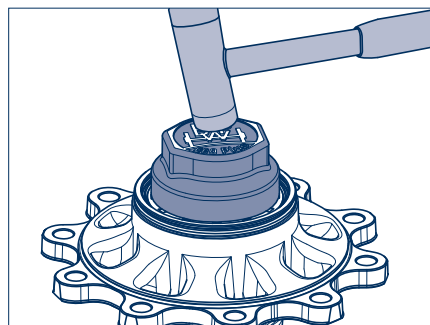

Picture 72

[24] Fit circlip (437) into the groove of the wheel hub (435).

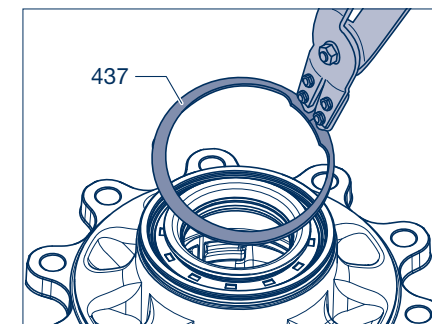

Picture 73

[25] ECO^{Plus} bearing from 07/2007:
No coarse dirt seal is used with the ECO^{Seal} seal (422).

ECO^{Plus} 8 - 9 t and 10 - 12 t bearings after 06/2005:

Press the coarse dirt seal (428) into the seat provided in the oil seal (422). (Coarse dirt seal is not used from 07/2007 onwards when using an ECO^{Seal} seal.)

ECO^{Plus} bearings 10 - 12 t before 05/2005:
Press seal (428) onto the thrust washer (421).

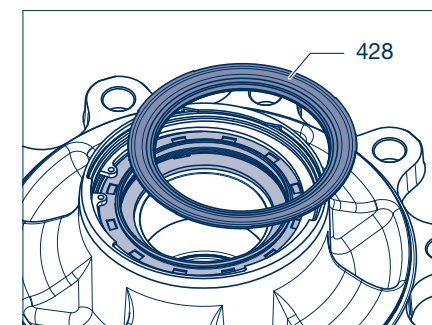

Picture 74

[26] Place the brake drum (380) onto the wheel hub (435). Insert the wheel studs (472) as far as possible into the hub.



Repair guide!

Make sure the wheel stud head is correctly seated on the brake drum.

A corrosion inhibitor may be needed to the spigot guide interface prior to fitting the brake drum.

[27] The flattened side of the wheel stud head must be in contact with the brake drum collar (anti-rotation lock).

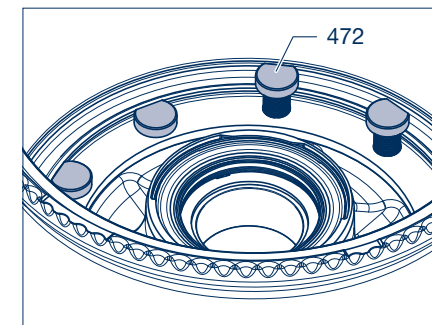

Picture 75

8 Dismantling and assembling the hub unit

- [28] Knock in the wheel stud (472) as far as the stop or draw in with the help of a sleeve and a nut (479).

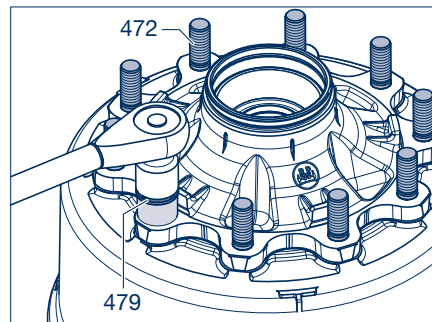

Picture 76

- [29a] ABS sheet metal exciter ring 8 - 9 t:
Use a new exciter ring (560)! Grease the exciter ring groove and bayonet locks on the exciter ring on both sides.

- [30a] Insert the exciter ring in the correct position. The rotational stops on the exciter ring must contact right-angled stop surfaces in the hub.

- [31a] Use a blunt object (e.g. screwdriver) to strike the exciter ring lightly behind the stop cams so as to rotate it clockwise as far as the stop.

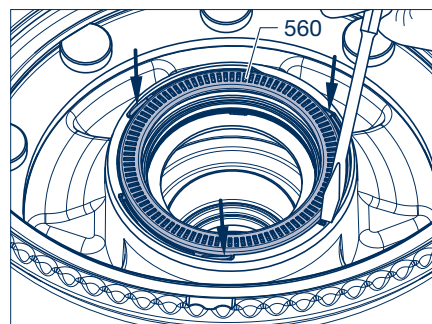

Picture 77



Repair guide!

Do not use impact tools to fit the exciter ring. Make sure there are no signs of damage on the teeth of exciter ring.

To avoid mistakes when mounting, we recommend using the BPW assembly tool 16.020.22953 when renewing the exciter ring.

- [31b] Press the assembly tool down on the outer circumference whilst turning clockwise and anti-clockwise to release or fasten the exciter ring.

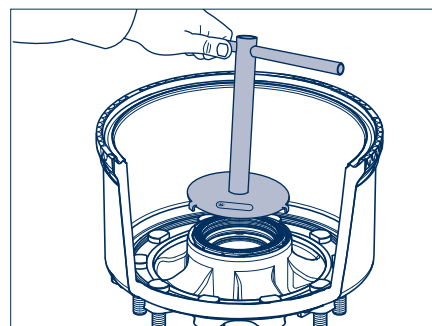

Picture 78

- [29b] ABS sheet metal exciter ring Series K 10 - 12t:



Repair guide!

Renew the exciter ring if there is insufficient preload to ensure firm seating of the exciter ring is no longer guaranteed.

- [30b] Clean the groove and stop surfaces for the exciter ring (560) (free from dirt, paint, etc.).

- [31b] Press the new exciter ring (560) onto the wheel hub (435), turning slightly anticlockwise. The lateral brackets (arrows) must clip into the groove on the neck of the wheel hub.

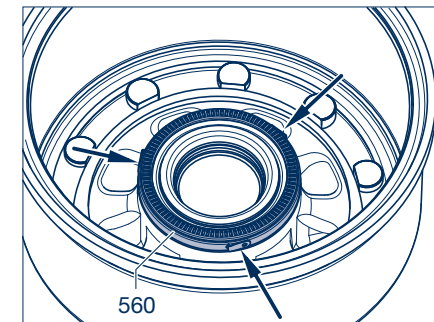

Picture 79

- [32] Fit outer roller bearing (441) into wheel hub (435).

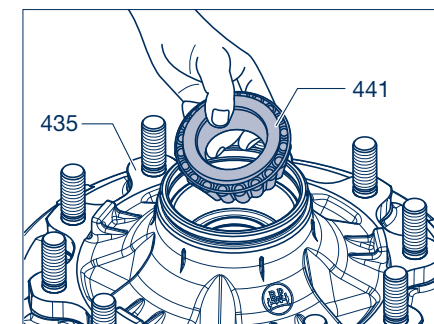

Picture 80

- [33] Place the keyed (445) thrust washer (with the embossed BPW) next to the tapered roller bearing (441).

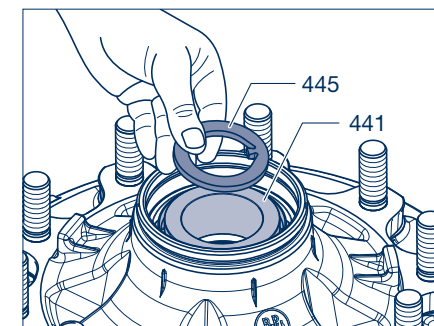

Picture 81

8 Dismantling and assembling the hub unit

- [34] Fit circlip (438) with axle nut (446) into the groove of the wheel hub.
Mounting the complete wheel hub, see page 61.

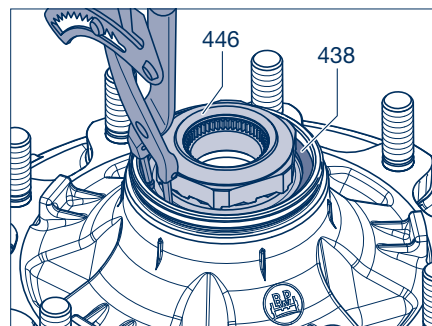

Picture 82

8.4 ECO Unit

- ☞ The ECO hub system is designed for long term lubrication (every 3 years or every 500,000 km). For demounting and fitting of the complete hub unit, see chapter 7.

- [1] To remove the outer taper roller bearing (441), remove the circlip (438) from the wheel hub (435).

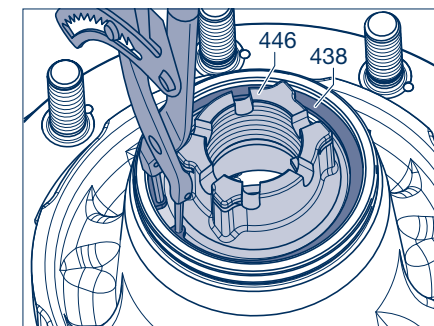

Picture 83

- [2] Remove axle nut (446), nose washer (445) and taper roller bearing (441).



Repair guide!
Mark both the hub and bearing to ensure correct positioning during re-assembly.
It is essential for the bearing inner races and rollers to be re-inserted in the same hubs.

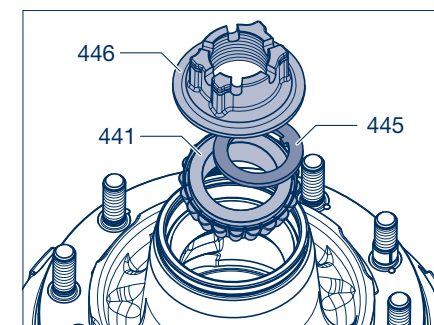

Picture 84

- [3] In order to remove the inner taper roller bearings (430), lever the dust cap (428, from 4/99) off the thrust washer (421).
- [4] Remove the circlip (437) from the wheel hub (435).
- [5] Remove thrust ring (421), complete with rotary shaft seal (424), O-ring (424) and taper roller bearing (430).
- [6] Thoroughly clean the taper roller bearing (430, 441) and inner space of the hub.
- [7] Inspect the taper roller bearing for wear, replacing if necessary.

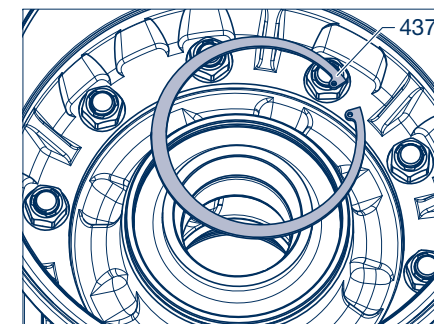

Picture 85

8 Dismantling and assembling the hub unit



Note:
We recommend removing the wheel to facilitate handling of the hub/drum unit when changing the bearing and the brake drum.

- [8] **Collar studs:**
Unscrew the nuts (474) from the wheel studs (472) on the drum side. Remove the wheel studs and remove down the hub (435).

Helical wheel studs:

Drive the wheel studs (472) out of the removed hub/brake drum unit (do not damage the threads of the wheel studs.)

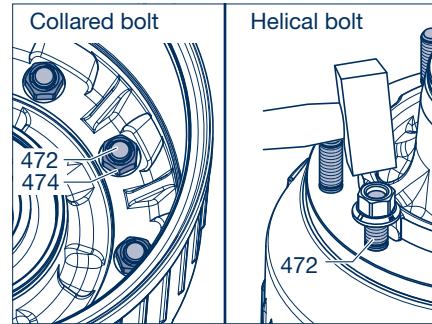

Picture 86

- [9] Drive the bearing outer races including thrust washer (440) out of the wheel hub (435).
- [10] Remove the dust cover (431) from the wheel hub and replace it with a new one.

- Mount the thrust washer making sure it is in the right position, see page 33.

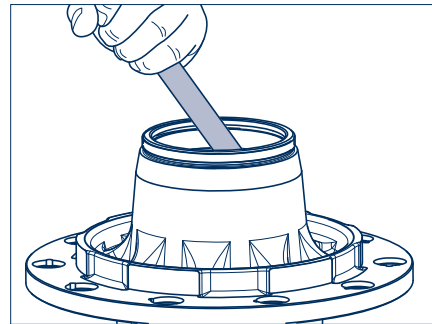

Picture 87

- [11] Centre the bearing outer races and insert them in the wheel hub. Install using a press (min. 6 t) and the BPW insertion tools for the outer bearing.

15.005.20052	Ø 100	bearing 32310
15.013.20052	Ø 113	bearing 33213
15.014.20052	Ø 123	bearing 33215

Inner bearing		
15.012.20052	Ø 123	bearing 33116
15.011.20052	Ø 142	bearing 33118
15.008.20052	Ø 160	bearing 32219



Repair guide!
Make sure the bearing cups are correctly seated in the wheel hub.

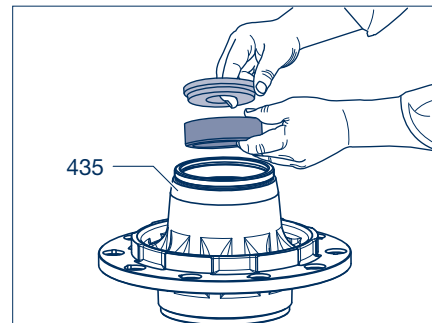

Picture 88

- [12] Use the BPW insertion tool

16.005.22111	Ø 139	for race 6 - 9 t
16.014.22111	Ø 159	for race 10 - 12 t

to press the new race (423) centrally into the wheel hub (435).

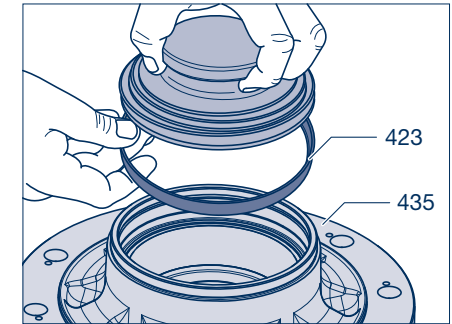

Picture 89

- [13] Press a new rotary shaft seal (422), with the open side facing upwards, onto the thrust ring (421) until it makes firm contact.

- [14] Version 6,5 - 12 t:
Insert the O-ring (424) into the groove of the thrust washer (421).

- [15] Smear seal lip and o-ring with BPW special longlife grease BPW ECO-Li^{plus}.

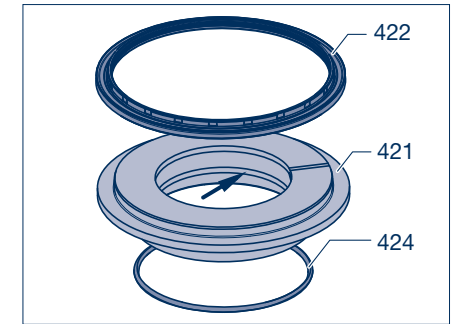

Picture 90

Helical bolt

- Collared bolts, see page 104.



Repair guide!
Inspect the wheel studs for serviceability and fit new wheel studs, if necessary.

A corrosion inhibitor may be needed to the spigot guide interface prior to fitting the brake drum.

- [16] Place the brake drum (380) onto the wheel hub (435). Ensure that the contact surfaces are clean.

- [17] Insert or knock in the wheel studs (472) as far as possible into the hub, paying attention to the anti-rotation lock in the brake drum (arrow). The flattened side of the wheel stud head must be in contact with the brake drum collar (anti-rotation lock).

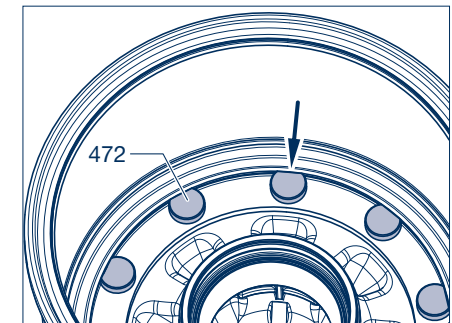

Picture 91

8 Dismantling and assembling the hub unit

- [18] Use a sleeve and nut (479) to draw the wheel studs (472) in as far as the stop, continue with step [19] on page 105.

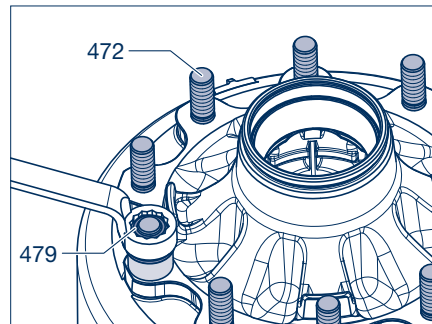

Picture 92

Collared bolt

- [16] Check wheel studs (472) and, if necessary, insert new wheel studs taking account of the splined pin (436, arrowed).

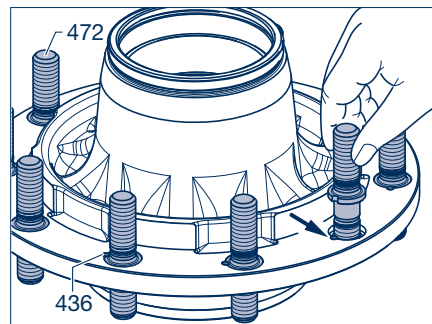

Picture 93

- [17] Place wheel hub (435) with the wheel studs (472) on the wheel or another brake drum (380).



Repair guide!
A corrosion inhibitor may be needed to guide prior to fitting the brake drum.

- [18] Fit brake drum (380) ensuring it is centred correctly and sits well. Screw on the nuts (474) with the locking notches facing upward and tighten to the correct tightening torque.

Tightening torques (tensile strength class = 10):

M 20 x 1.5 M = **300 Nm** (280 - 330 Nm)
M 22 x 2 M = **400 Nm** (370 - 440 Nm)

Japan connection (8 wheel studs/pitch circle Ø 285):

M 20 x 1.5 M = **300 Nm** (280 - 330 Nm)

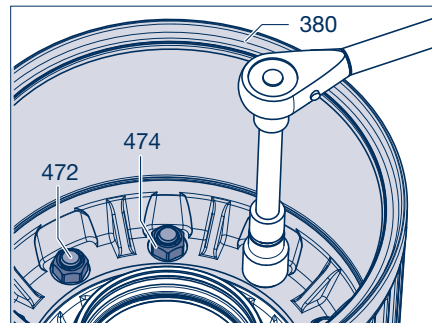

Picture 94

- [19] Work BPW special longlife grease ECO-Li^{Plus} thoroughly into the spaces between the conical rollers and the race (430, 441).

BPW special longlife grease
ECO-Li^{Plus}
Grease quantity per
taper roller bearing

Axle load	①	②
	Inner bearing	Outer bearing
6000 - 9000 kg	120 g	120 g
10000 - 12000 kg	170 g	120 g
13000 - 14000 kg	230 g	150 g

Smear the remaining grease into the outer bearing races of the hub (435).



Note:
We recommend greasing the bearings with BPW grease applicators:

99.00.000.9.54 for bearing 33116/32310
99.00.000.9.55 for bearing 33118/33213.

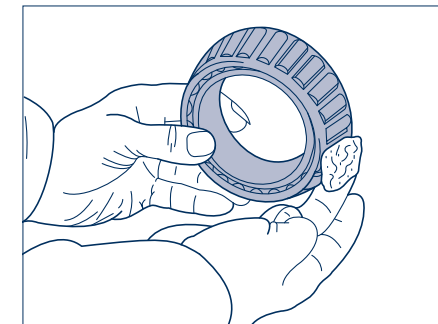

Picture 95

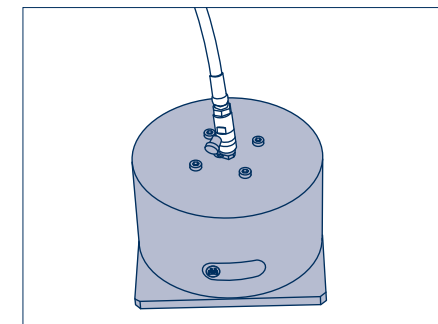

Picture 96

- [20] Fit inner roller bearing (430) into wheel hub (435).



Repair guide!
Do not mix up bearing races and outer bearing rings.

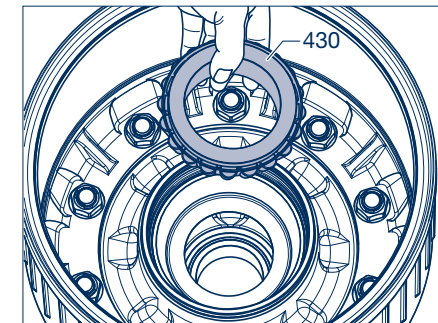

Picture 97

8 Dismantling and assembling the hub unit

- [21] Insert thrust washer (421), complete with rotary shaft seal (422), into the bearing race (423).

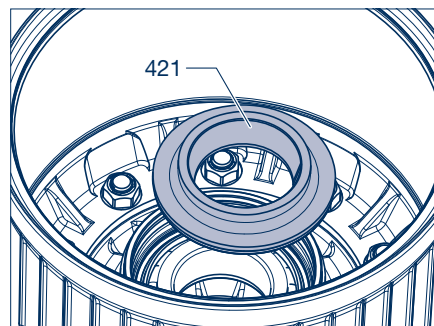

Picture 98

- [22] Snap circlip (437) into groove of wheel hub (435).

- [23] In the ECO Unit up to 12 t, insert the O-Ring (424, arrow) into the groove in the thrust washer (421).

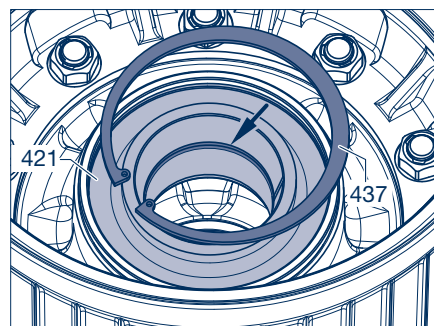

Picture 99

- [24] Clip the coarse dirt seal (428) onto the thrust washer (421).

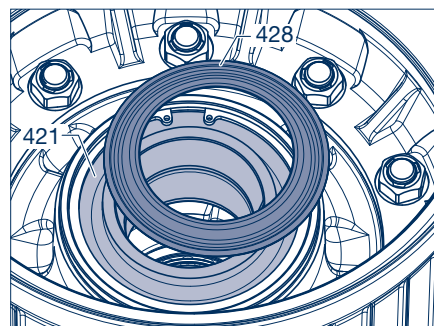

Picture 100

- [25] Fit outer roller bearing (441) into wheel hub (435).

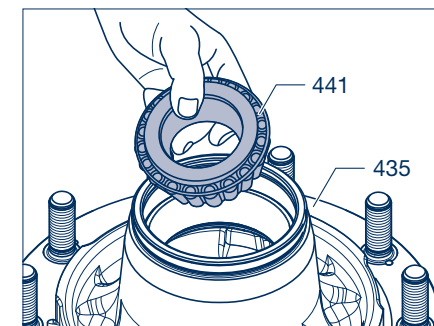

Picture 101

- [26] Attach keyed washer (445) to axle nut (446), using grease.



Repair guide!
The embossed face (BPW and code number) must point to the taper roller bearing (441).

- [27] Insert axle nut into wheel hub (435).

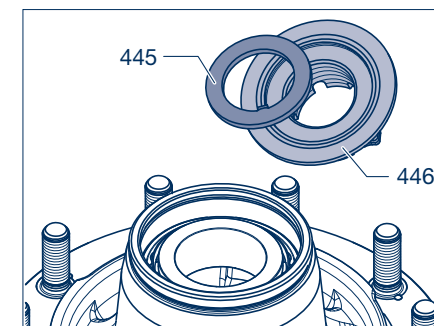

Picture 102

- [28] Snap circlip (438) into groove of wheel hub (435).

- For fitting of complete hub unit, see page 65.

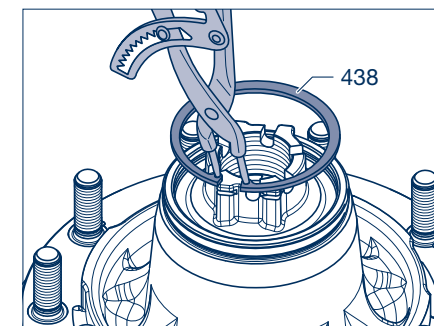

Picture 103

8 Dismantling and assembling the hub unit

8.5 Conventional hub bearing

- [1] Reset brake (remove wheels).
- [2] Unscrew the hub cap (460).
- [3] Remove the split pin (447) from the castle nut (446) and unscrew. Remove the washer (445) from the stub.



Danger!
RISK OF INJURY!
The wheel hub brake drum unit must be secured against falling.

Use a hoist or a second person to help.

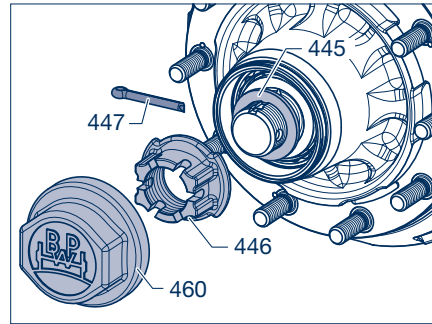

Picture 104

- [4] Install hub cap puller (BPW No. see page 18) onto the wheel hub assembly (435) with brake drum (380). Extract from the stub axle.



Repair guide!
Mark both the hub and bearing to ensure correct positioning during re-assembly. It is essential for the bearing inner races and rollers to be re-inserted in the same hubs.

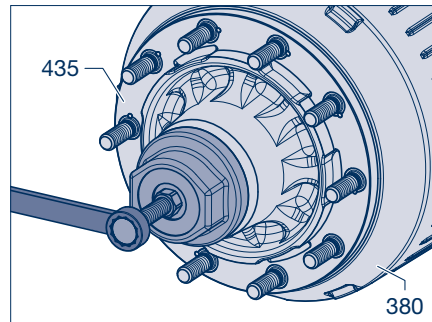

Picture 105

- [5] Position puller. Pull off the inner taper roller bearing (430), the grease seals (422, 423) and the thrust washer (420) together from the axle stub.

Extractor:
BPW no. 02.0125.10.00 for axles 6.5 to 14 t.



Repair guide!
For 10 t axle series K with ABS/ABV: Unscrew the sensor holder (542).

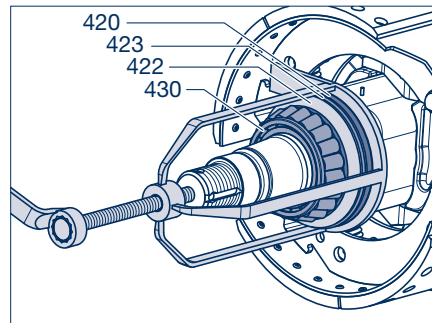

Picture 106

- [6] Thoroughly clean the tapered roller bearing (430, 441) and the spaces inside the hub.
- [7] Check the tapered roller bearing for wear and renew it if necessary.



Note:
We recommend removing the brake drum to facilitate handling of the hub/drum unit when changing the bearing.

- [8] Unscrew the nuts (474) from the wheel studs (472) on the drum side.

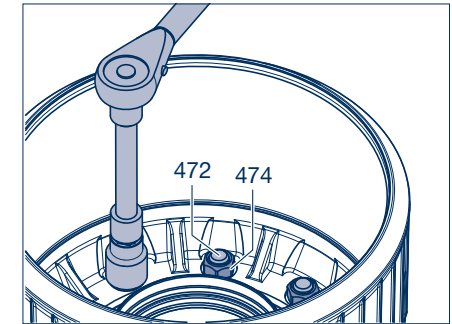

Picture 107

- [9] Remove the wheel studs (472) and then the hub (435).

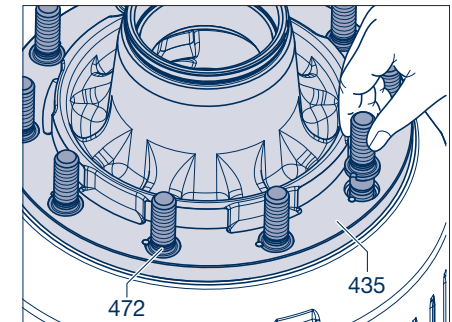

Picture 108

- [10] Drive the bearing outer races out of the hub.

- [11] Insert the larger bearing outer track with grease shield (431) and the small bearing outer track (without a grease shield), into the wheel hub (435) using an insertion tool until contact is made.

Insertion tools for outer bearing

15.005.20052	Ø 100	bearing 32310
15.013.20052	Ø 113	bearing 33213
15.014.20052	Ø 123	bearing 33215
15.003.20052	Ø 138	bearing 32314

Insertion tools for inner bearing

15.014.20052	Ø 123	bearing 33215
15.012.20052	Ø 123	bearing 33116
15.011.20052	Ø 142	bearing 33118
15.008.20052	Ø 160	bearing 32219
15.007.20052	Ø 188	bearing 32222

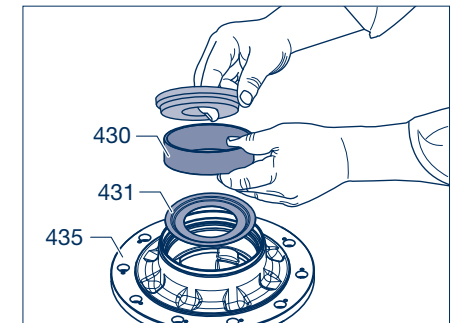

Picture 109

-  For the correct position of the grease shield (431), refer to page 35.

8 Dismantling and assembling the hub unit

- [12] Check wheel studs (472) and, if necessary, insert new wheel studs taking account of the splined pin (436, arrowed).

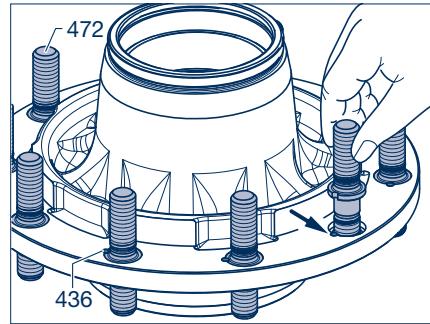

Picture 110

- [13] Insert wheel hub (435) with wheel studs (435) into the rim.



Repair guide!

A corrosion inhibitor may be needed to guide prior to fitting the brake drum.

- [14] Fit brake drum (380) ensuring it is centred correctly and interfaces correctly. Screw on the nuts (474) with the locking notches facing upward and tighten to the correct tightening torque.

Tightening torques (tensile strength class 10):

M 20 x 1.5 (SW 30) M = **300 Nm** (280 - 330 Nm)
M 22 x 2 (SW 32) M = **400 Nm** (370 - 440 Nm)

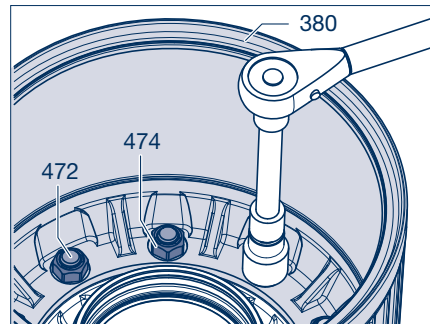

Picture 111

- For hub and brake drum installation and hub bearing adjustment, see page 67.

Trilex wheels

- [15] Fix brake drum (380) onto Trilex wheel (435).
[16] Tighten hexagon bolts (390) and lock nuts (392) to appropriate torques.

Tightening torques:

M 20 - 8 (SW 30) = **335 Nm** (320 - 350 Nm)
M 20 - 10 (SW 30) = **450 Nm** (420 - 500 Nm)



Repair guide!

Check the self locking function of the nut. Maximum use of the lock nut is 3 times.

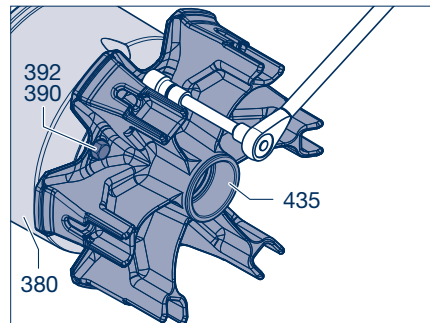

Picture 112

- For TRILEX hub installation and bearing adjustment, see installation of conventional hub bearing, see page 67.

ABS / ABV 9

- [1] Check sensor (570) for damage and displacement (displacement force 100 - 200 N).
[2] Lubricate clamping bush (571) and sensor with special grease (replace clamping bush). Before fitting hubs, always press clamping bush and sensor up to endstop.

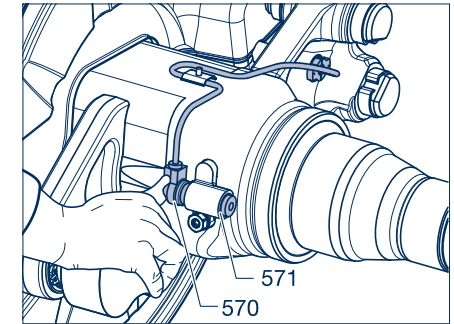

Picture 1

Pressed exciter ring (560) - ECO Plus 3

- [3] Lever the exciter ring from the wheel hub (435). In doing so, avoid damage to the base of the wheel hub.
[4] Clean the stop surfaces for the exciter ring (free from dirt, paint, etc.).
[5] Fit the new exciter ring and fasten with the assembly tool (BPW No. 16.038.22953) until it is in contact, see page 78.

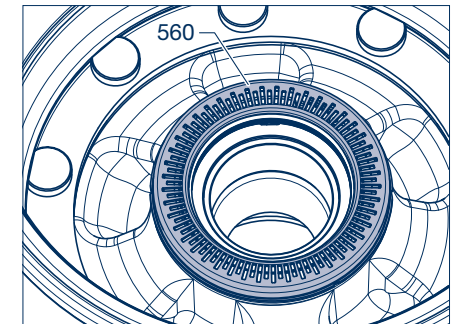

Picture 2

The exciter ring (560) is shrink-fitted

- [3] To change a damaged exciter ring heat the exciter ring with a torch and extract.
[4] Heat the replacement exciter ring from 80° to max. 120°C and press into place, ensuring the seat is clean and undamaged.

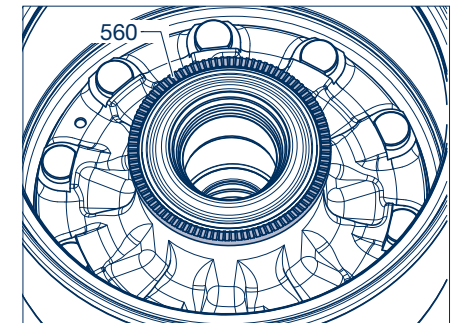

Picture 3

9 ABS / ABV

The exciter ring (560) is clipped on with a lateral bracket



Repair guide!

Renew the exciter ring if the reduced preload values mean that firm seating of the exciter ring is no longer guaranteed.

- [3] Clean the groove and stop surfaces for the exciter ring (free from dirt, paint, etc.).
- [4] Press the new exciter ring onto the wheel hub, turning slightly anticlockwise.
- [5] The lateral brackets must clip into the groove on the neck of the wheel hub.

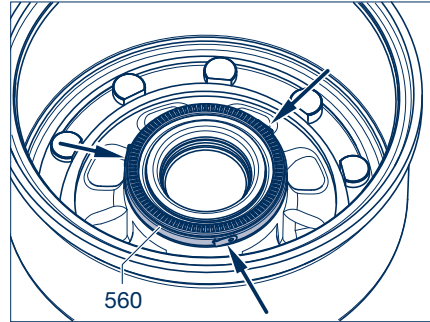

Picture 4

The exciter ring (560) is clipped on with a bayonet lock

- [3] To renew a damaged exciter ring, release the old exciter ring by striking it lightly anticlockwise and removing it.



Repair guide!

Renew the exciter ring if the reduced preload values mean that firm seating of the exciter ring is no longer guaranteed.

- [4] Clean the groove and stop surfaces for the exciter ring (free from dirt, paint, etc.).
- [5] Grease the exciter ring groove and bayonet locks on the exciter ring on both sides.
- [6] Insert the exciter ring in the correct position. The rotational stops on the exciter ring must contact right-angled stop surfaces in the hub.
- [7] Use a blunt object (e.g. screwdriver) to strike the exciter ring lightly behind the stop cams so as to rotate it clockwise as far as the stop.

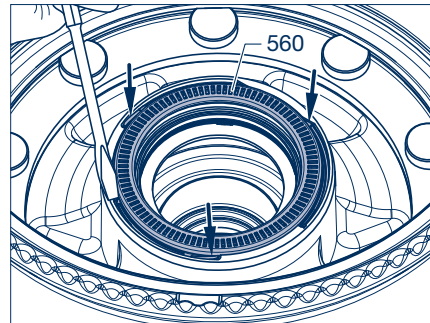

Picture 5



Repair guide!

Do not place impact tools in the teeth of the exciter ring. Make sure there are no signs of damage on the teeth of exciter ring.

To avoid mistakes when mounting, we recommend using the BPW assembly tool 16.020.22953 when renewing the exciter ring.

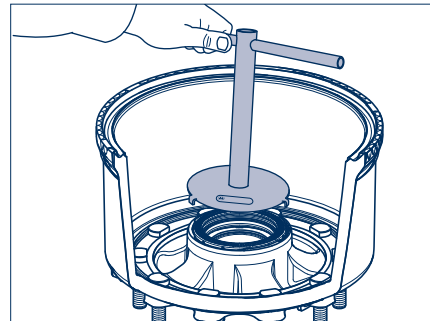

Picture 6

Press the assembly tool down on the outer circumference at the same time as turning clockwise or anticlockwise to release or fasten the exciter ring.

Back plate for - Brake ECO Drum 10

Removal

- [1] Release the return spring (508) from the front dust cover.

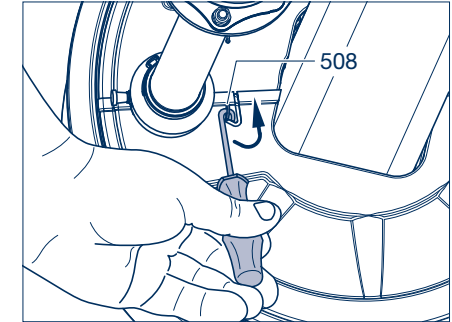

Picture 1

- [2] Unscrew the (510, M10 / SW 13) securing bolts from the brake anchor plate.

- [3] Remove the dust covers.

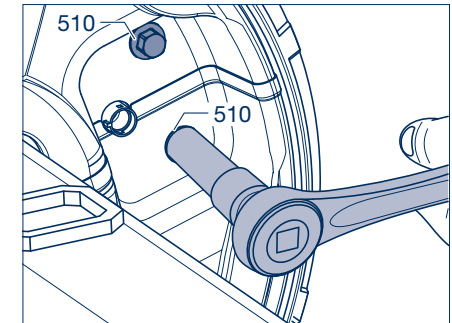

Picture 2

Assembly

- [4] Check the return spring (508) on the dust cover (501, 503) for corrosion; fit a new one if necessary.

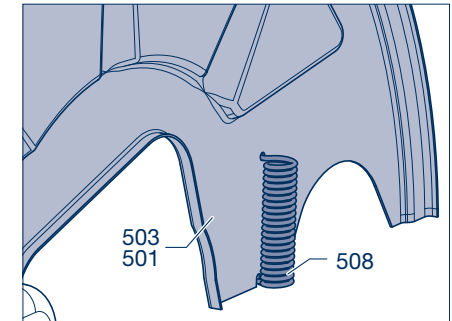

Picture 3

10 Back plate for - Brake ECO Drum

- [5] Insert the dust cover (501, 503) with return spring (508) into the groove (arrow) on the brake anchor plate (camshaft end).

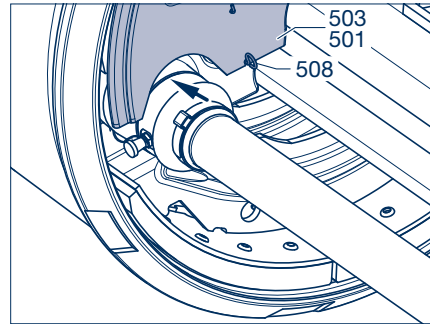

Picture 4

- [6] Use the securing bolt (510, M 10 / SW 13) to secure the dust cover (501, 503) onto the brake anchor plate.
Tightening torque: 43 Nm

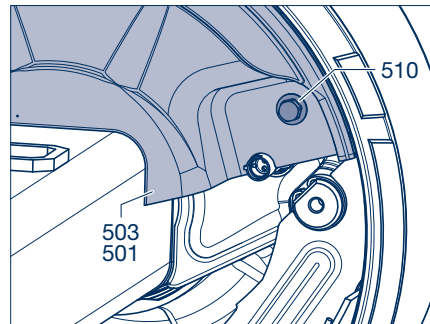

Picture 5

- [7] Mount the opposite dust cover (502, 504) in the same way.

- [8] Hook in the return spring (508).



Repair guide!

Check the dust cover is correctly seated on the edge of the brake drum and readjust it slightly if necessary.

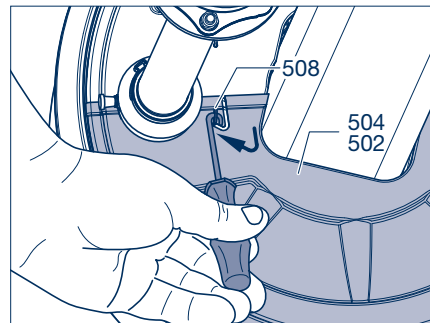

Picture 6

Brake camshaft 11

- Remove the wheel/hub unit and brake shoes, see sections 7.1 and 7.2.

- [1] Unscrew nut (268, SW 32) of brake camshaft (240, 241).
Remove the wear indicator (266).
[2] Remove slack adjuster (280) with disc (262).

Brake camshafts built from 10.2000

- [3] Remove the push-on bush (260) from the brake camshaft.

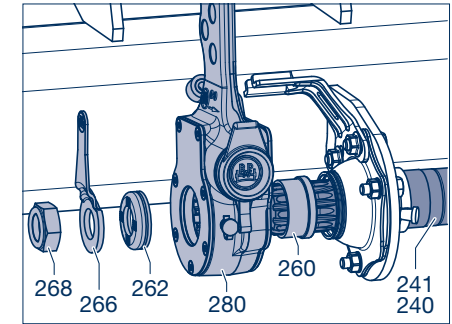

Picture 1

Brake camshafts built from 10.2000

- [3] Remove the retaining ring (260) from the groove and the sealing ring (272) from the brake camshaft.

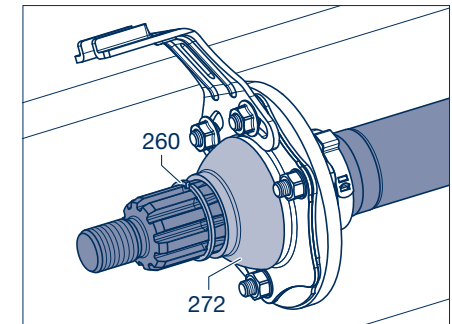

Picture 2

- [4] Dis-assemble hex nuts (232, 289 / SW 13), spring washers (231) and screws (230, 288).

- [5] Remove spherical bearing support plates (285, 286).



Note:

From 2016, the inner camshaft support bearing fixing bolts will be standardised and the hexagon nuts (232) with spring washers (231) will be replaced with self-locking nuts.

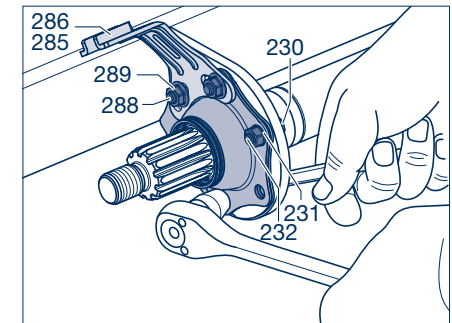

Picture 3

11 Brake camshaft

- [6] Check the spherical bearing (225) in the support bearing and the two sealing rings (271, 272) for wear (max. bearing play 0.8 mm).

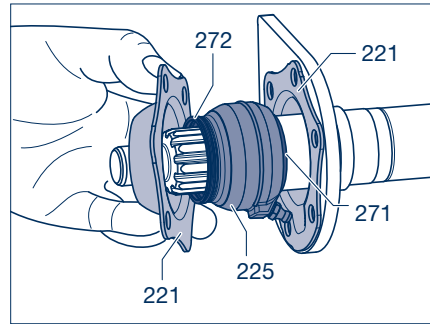

Picture 4

- [7] Open clamp (274) on rubber seal (270).
- [8] Push the rubber seal with circlip to the middle of the brake camshaft (240, 241).
- [9] Remove circlip (250) from the groove. Take brake camshaft out of the brake anchor plate.

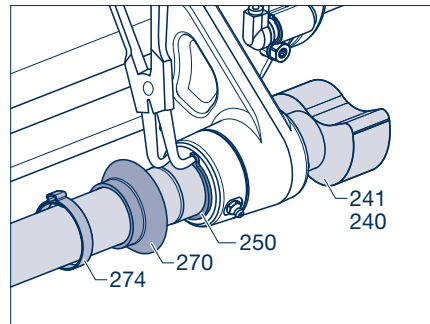

Picture 5

- [10] Check bush (210) in brake anchor plate and, if necessary, change bush (max. bearing play 0.8 mm).
- [11] Drive in new bush with mandrel (BPW no. 05.001.04.04.0), with the ring groove (arrowed) pointing towards the grease nipple.
- [12] On the outside, the bush must stand back 7.2 ± 0.5 mm. Only apply light strokes when driving in and out; apply counter-pressure to brake anchor plate if necessary.

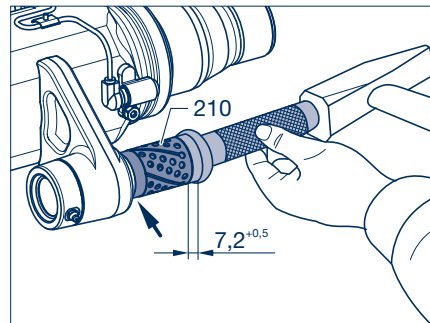

Picture 6

Brake camshaft, series H / K

- [13] Insert circlip (250) into the groove, push combined seal (252) and O-ring (256, green, $\text{Ø} 40 \times 2.5$) up to the bearing seat.

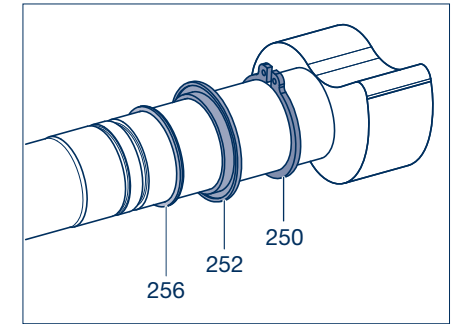

Picture 7

Brake camshaft, series N

- [13] Install ring (254) and O-ring (256, green, $\text{Ø} 40 \times 2.5$) on the bearing journal.

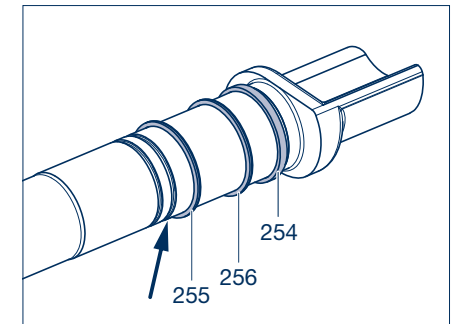

Picture 8

- [14] Grease bearing with BPW special longlife grease ECO-LiⁱPlus.



Repair guide!

Insert an O-ring (255, black, $\text{Ø} 37 \times 2.6$) into the middle groove (arrow) in low-maintenance brake camshaft bearings from 02/2002 onwards and brake camshafts with the end digit 3 and 4.

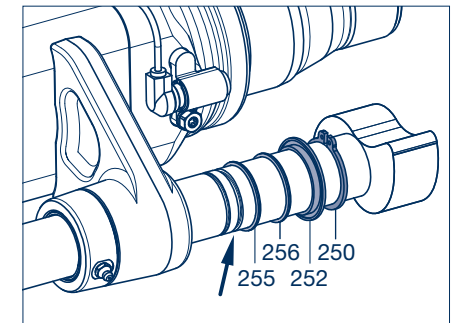

Picture 9

11 Brake camshaft

- [15] Insert the brake camshaft (240, 241) halfway into the brake anchor plate.
- [16] Push on the plastic ring (258) with the domed side pointing towards the middle of the axle, circlip (250), rubber seal (270) and the clamp (274) onto the brake camshaft.

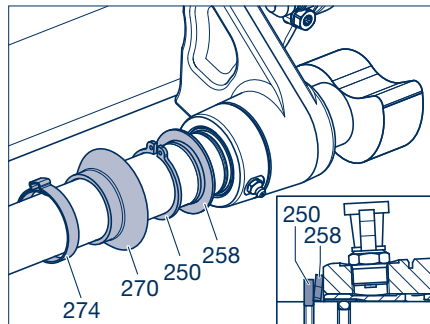

Picture 10

- [17] Push the brake camshaft (240, 241) to the stop on the brake carrier.
- [18] Position the plastic ring (258) until it contacts the brake carrier.
- [19] Insert the locking ring (250) in the groove of the brake camshaft.
- [20] Position rubber seal (270) and secure with clamp (274).

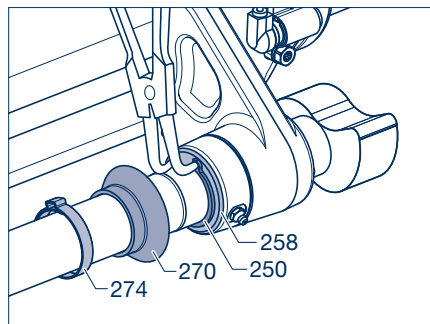

Picture 11



Note!
Old versions of the support bearing must be converted to the new version.

- [21] Install spherical bearing (225) with the two grease sealing rings (271, 272) inner and outer, to the support bearing holder.



Repair guide!
Mount the grease nipple in the direction of the wheel.

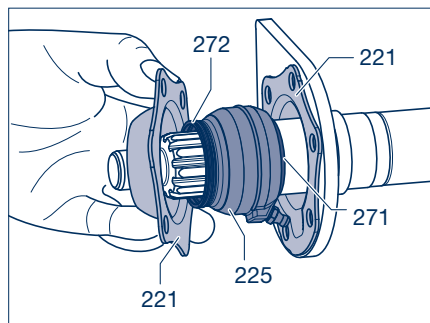

Picture 12

- [22] Replace self-cutting bolts (230) with hexagon bolts.
- [23] Mount the nuts (232, 289 / SW 13) towards the slack adjuster (280).

Tightening torques:

Hexagon bolt (230) with M 8 hex nut (232, SW 13) and spring washer (231).
M 8 M = 23 Nm

Hexagon bolt (288) with locknut M 8 (289, SW 13) for securing the ECO-Master shaped plate (285, 286) tighten after mounting and adjusting the slack adjuster), see page 109.

M 8 M = 28 Nm

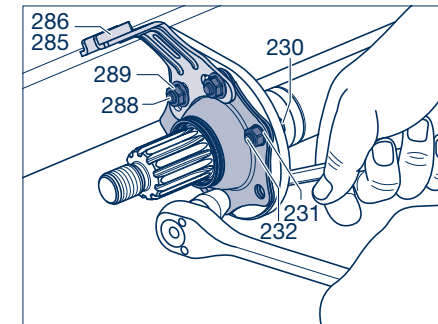

Picture 13



Note:

From 2016, the inner camshaft support bearing fixing bolts will be standardised and the hexagon nuts (232) with spring washers (231) will be replaced with self-locking nuts.

Tightening torque: 28 Nm

Old design per axle:

8 x Hexagon bolt M 8 x 25 (230, 288)
4 x Hexagon nut M 8 (232)
4 x Spring washer B 8 (231)
4 x Lock nut M 8 (289)

New design per axle:

8 x Hexagon bolt M 8 x 30 (230)
8 x Lock nut M 8 (232)

- [24] Check that the brake camshaft rotates freely.
- [25] Position the rubber seal (270) to the interface of the brake carrier. If present, snap the rubber seal into the groove of the brake camshaft (arrow).
- [26] Install the securing clip (274).

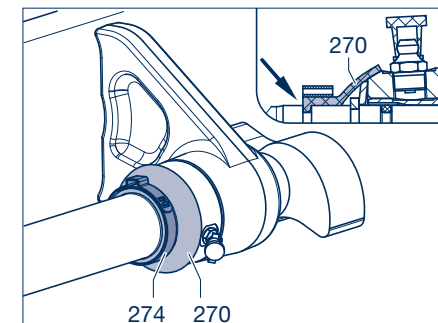

Picture 14

11 Brake camshaft

[27] Grease all bearing surfaces of the brake camshaft via the grease nipples, using BPW special longlife grease ECO-Li^{Plus}.

[28] Push the spacer bush (260) onto the brake camshaft to act as a slack adjuster stop. Check the brake camshaft again to ensure it can move freely.

After the conversion to the new brake camshaft bearing, the sealing ring (272) and retaining ring is omitted (260, see Picture 2).

 Fit brake shoe and the complete hub unit, see chapter 7.

 Fit slack adjuster, see pages 121 and 122 to 123.

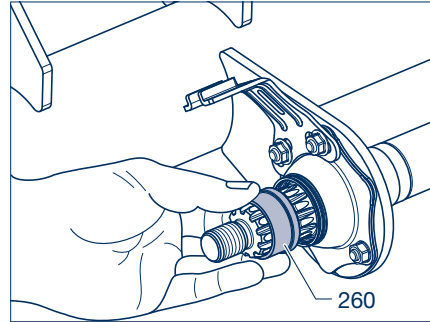

Picture 15

Manual slack adjuster GSK 12

- [1] Apply BPW special longlife grease ECO-Li^{Plus} onto teeth of brake camshaft (240, 241).
- [2] Slide slack adjuster (280) onto the brake camshaft.
- [3] Position washer (262) with the countersink pointing towards the slack adjuster and screw on new locknut (268, SW 32). Tighten to a torque of 120 Nm.

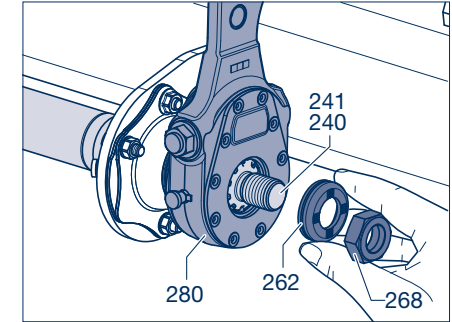

Picture 1

Brake adjustment

- [4] Align slack adjuster using adjusting hexagon with reference to brake cylinder yoke.
- [5] Insert and lock the clevis pin. Engage return spring (295) when lever length is between 150 to 180 mm.



Note:
BPW brake cylinders with a round-hole yoke do not have an outer return spring (295).

- [6] The cylinder push rod and slack adjuster should be at an angle of approximately 90° to each other when the brake is applied.
- [7] Set play "a" to 10 - 12 % of connected brake lever length "B". E.g. if brake lever length = 150 mm, play = 15 - 18 mm. Grease all points with BPW special longlife grease ECO-Li^{Plus}.

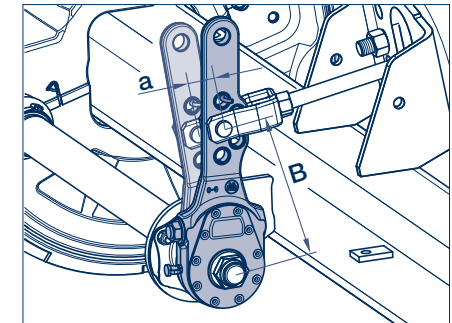

Picture 2

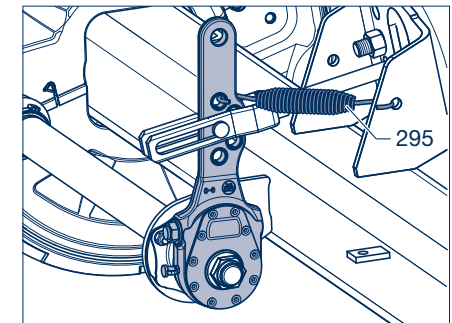

Picture 3

13 Automatic slack adjuster ECO-Master

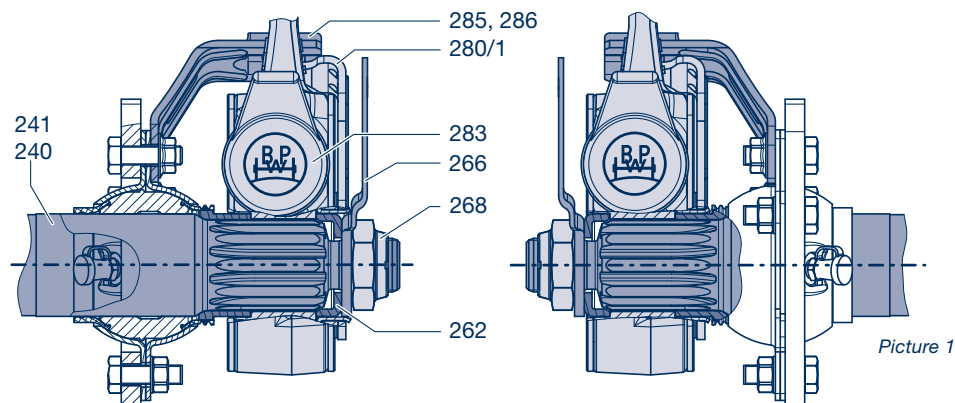

Picture 1

- [1] Grease teeth of brake camshaft 240, 241 with BPW special longlife grease ECO-Li^{Plus}.
 - [2] Slide automatic slack adjuster ECO-Master (280) onto the brake camshaft.
 - [3] In this position, fit yoke of the reaction bracket (285, 286) onto control lever (280/1) (note left and right versions).
- See section 14.2 for wear sensor installation.

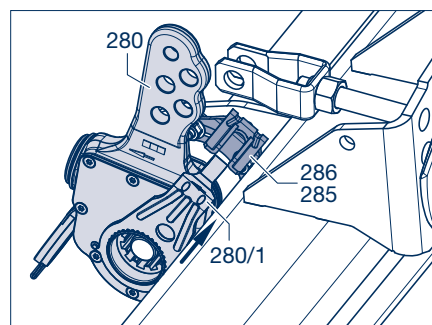

Picture 2

- [4] Fit washer (262) and wear lining indicator (266) pointing vertically upwards, and new lock nut (268, SW 32) and tighten to 120 Nm.
- [5] Remove cap (283), press down clutch sleeve with ring spanner (SW 19, arrowed) and, by turning to left or right, align the bolt hole in brake lever with round hole or end of slot in the yoke.

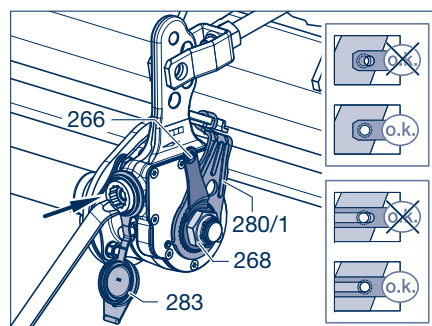

Picture 3

- [6] Insert clevis pin and lock.
- [7] Insert return spring (295) when lever length is 150 to 180 mm.



Note:
BPW brake cylinders with a round-hole yoke do not have an outer return spring (295).

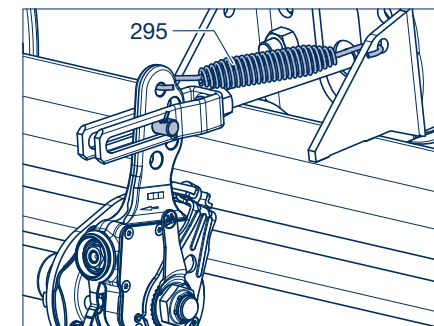

Picture 4

- [8] Holding the clutch sleeve down, press control lever (280/1) and reaction bracket (285, 286) in the direction of the arrow until it reaches the endstop.
- [9] The lug on the control lever will now point to the control point.
- [10] Secure plate with two hexagon bolts (230 / 288) and lock nuts (232 / 289, SW 13) to inner side of supporting bearing (see page 119). Tightening torque: M = 28 Nm.



Repair guide!
Control lever lug must align to the control point after tightening up!
(Basic setting)

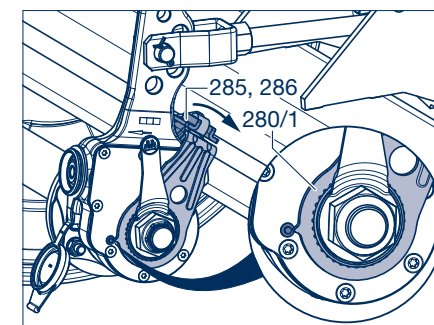

Picture 5

Adjusting the brake:

- [11] Set play "a" to 10 - 15 % of the connected brake lever length "B" by turning the adjusting hexagon (keep clutch sleeve pressed down). E.g. if brake lever length 150 mm = play 15 - 22 mm.
- [12] When the brake is applied, the cylinder push rod and slack adjuster must be at an angle of approximately 90° to each other.
- [13] Grease all points with BPW special longlife grease ECO-Li^{Plus}.
- [14] Fit plastic cap (283).

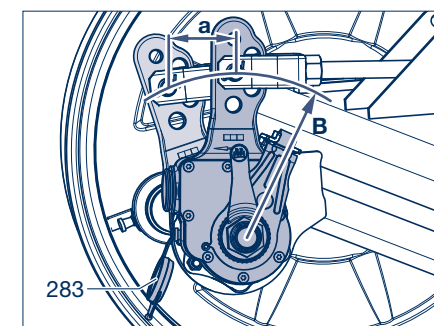

Picture 6

- The setting of the ECO-Master must be readjusted after a change or renewal of the brake cylinder, brake camshaft or the automatic slack adjuster.

14 Wear sensing

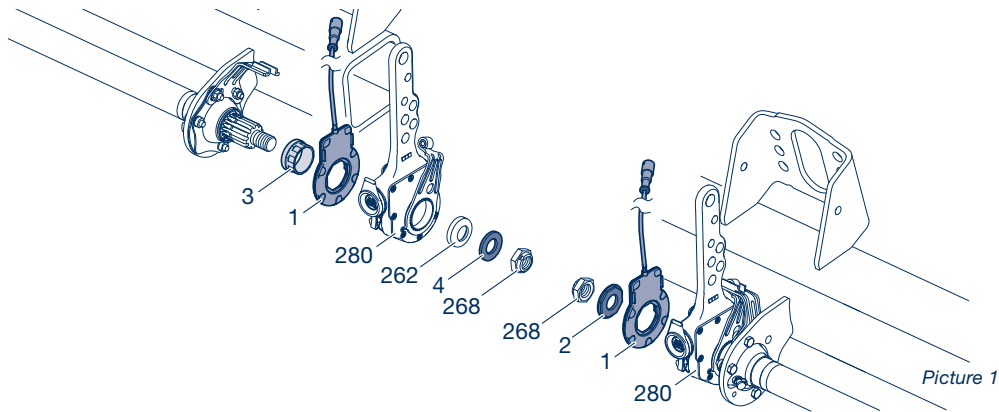

The wear sensors must only be installed at the same time as the brake linings are replaced!

Wear sensing does not replace the statutory inspections!

14.1 Function

The wear sensor moves with the slack adjuster. The inner disc (coloured) with the internal hexagon profile is connected to the brake camshaft in a friction connection, so it turns with the camshaft. There are markings for the first setting on the wear sensor. The projection on the inner disc must be adjusted in advance (A) depending on the thickness of the new linings when the system is first fitted.

As soon as the slack adjuster has adjusted through 90° (B), in other words the camshaft and the inner disc have turned through 90°, the wear limit has been reached and the sensor sends the „SERVICE“ signal to the Brake Monitor. The red and green LED lights on the brake monitor flash alternately. The service signal changes from black to red and remains in operation without voltage. The brake linings must be renewed!

There is no need to renew the wear sensor; it should be turned back to the starting position like the automatic slack adjuster. It is ready for use again once it has been reset.



Note:
The wear sensor for the drum brake does not provide the „WARNING“ function on the Brake Monitor.

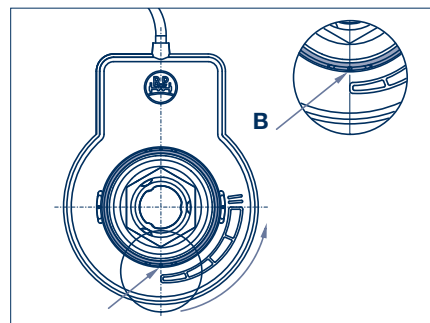
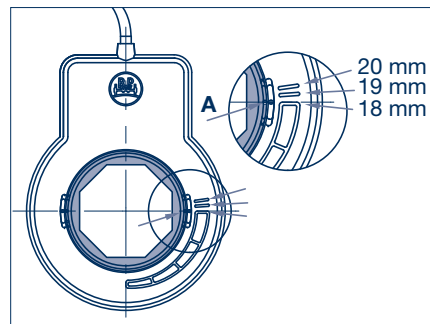

Picture 3

14.2 Installations instructions

- [1] Reset the slack adjuster (280, 281) and renew the brake linings (330), see chapter 7.
- [2] Mount the wear indicator on the side opposite to the control lever (280/1) (see arrows). One of the two slack adjusters must be removed.
- [3] Remove the hexagon nut (268, SW 32) and brake lining wear indicator (266). (Item 266 is discarded.)
- [4] Working on the side of the slack adjuster to be removed, pull the washer (262), the ECO-Master automatic slack adjuster (280) and the bush (260) off the brake camshaft. (Item 10 is replaced.)
- [5] Set the lining thickness (A) on the wear sensor by turning the inner disc.

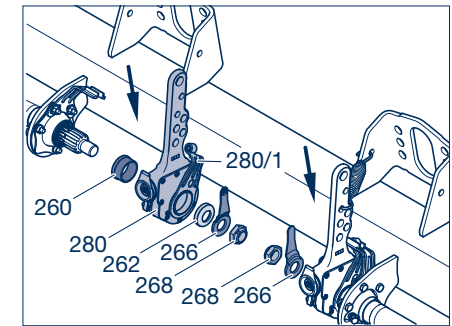

Picture 4

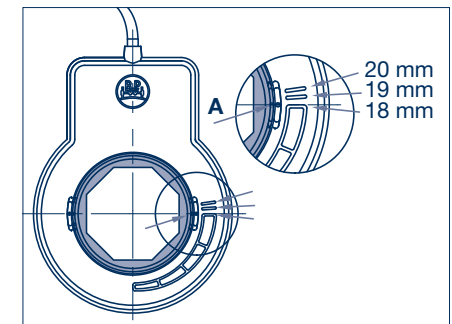

Picture 5

Where the slack adjuster has been removed

- [6] Apply BPW special longlife grease ECO-LiPlus to the tooth profile of the brake camshaft.
- [7] Push the adapter bush (3), wear sensor (1) and ECO-Master automatic slack adjuster (280) onto the camshaft.

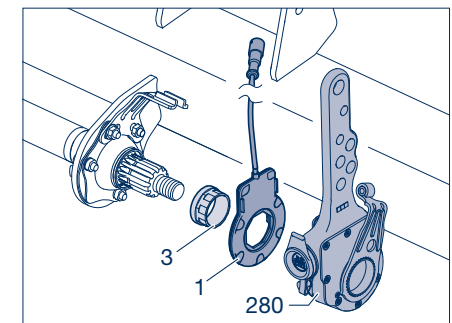

Picture 6

14 Wear sensing

- [8] Adjusting the brake, see page 109.



Repair guide!
When doing this, make sure that the slack adjuster does not contact the wear sensor otherwise the setting of the inner disc of the wear sensor (A, picture 5) will be incorrect.

- [9] Place the washer (262) and new plastic disc (4) on the brake camshaft and tighten the locking nut (268, SW 32) to a tightening torque of 80 - 90 Nm.

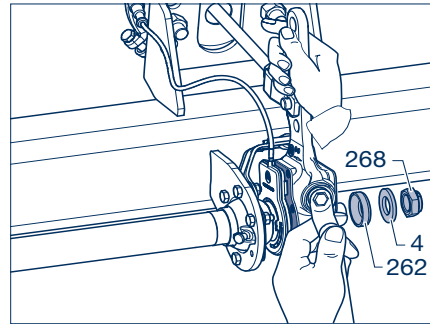

Picture 7

Side of the mounted slack adjuster (280)

- [10] Adjusting the brake, see page 109.

- [11] Push the wear sensor (1) and the adapter disc (2) onto the camshaft.

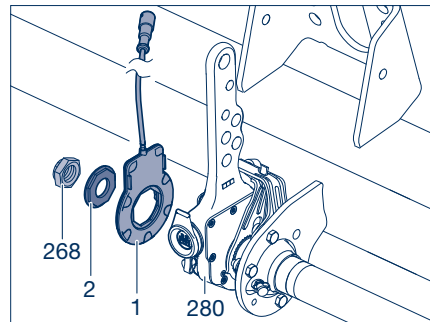

Picture 8

- [12] Use the assembly aid (BPW code number 02.1427.01.00) to secure the adapter disc to prevent it from turning as well and tighten the hexagon nut (268, picture 8) to a tightening torque of 80 - 90 Nm.

- [13] Secure the sensor cable to the base plate using a cable tie. Make sure the automatic slack adjuster can move freely!

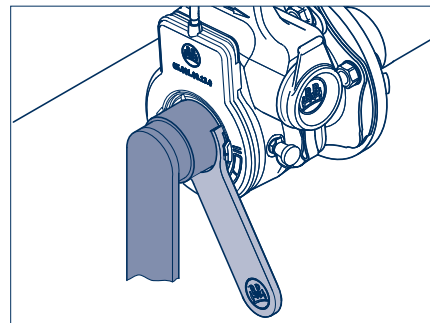

Picture 9

Brake cylinder 15

15.1 Maintenance

Statutory inspections must be carried out. No other particular maintenance work is required.

The diaphragm cylinder should be removed and cleaned at least every 2 years. Only new wearing parts are to be fitted when installing brake cylinders.



Danger!
DANGER OF FATAL INJURY !
It is not possible to strip down the spring brake section!
Never apply force in an attempt to open it.

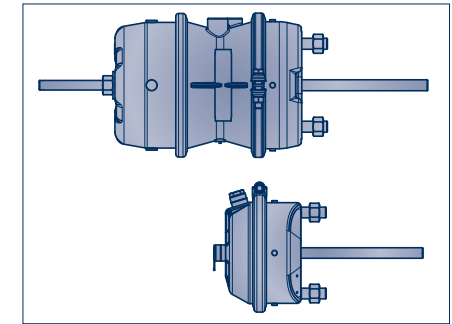

Picture 1

15.2 Preparations for assembly

- In order for the brake cylinder to function correctly, the contact surfaces on the mounting bracket should be clean and flat within 0.4 mm.
- During conversion or retrofitting work, make sure there is no damage on the air cylinder bracket or the contact surface.
- The mounting brackets should only be primed prior to installation of the bracket cylinder (max. paint thickness 100 µm).
- BPW brake cylinders must only be installed using the fixtures supplied by BPW. No other parts such as washers, plates, retaining rings, etc. may be used.

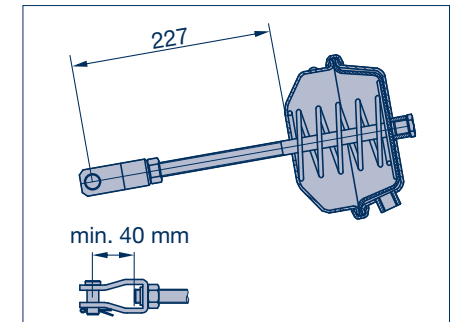

Picture 2

15.3 Installation diaphragm cylinder (410)

- [1] Screw the lock nut and yoke onto the cylinder push rod.
 - [2] Set the specified push rod length in relation to the cylinder base (maintain a clearance of min. 40 mm!). Initially screw the lock nut on to secure the yoke.
- Spring brake cylinder see chapter 15.4.
- [3] Reset the slack adjuster.
 - [4] Fit the brake cylinder to the mounting bracket. Check the required brake lever length to appropriate hole in the slack adjuster arm.

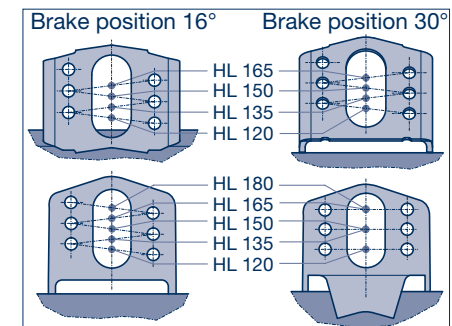

Picture 3

15 Brake cylinder

- [5] Fit on the mounting nuts until tight.
- [6] Tighten alternative sides to **180 Nm** (180 - 210 Nm) using a torque wrench.
- [7] Tighten the lock nut (1) on the yoke to 80 Nm.

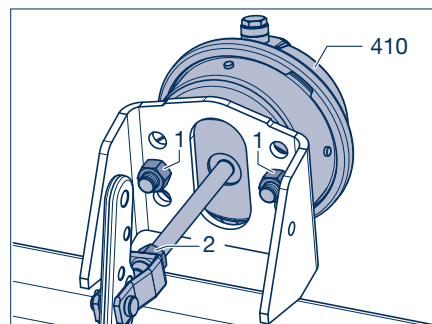

Picture 4



Note:
BPW brake cylinders with a round-hole yoke do not have an outer return spring (295).

- [8] An outer return spring (295, picture 4 page 109) is required if slot-type yokes are used. This must be taken into account in the EC brake calculation.
- [9] Remove the plug from the drain hole at the lowest point.

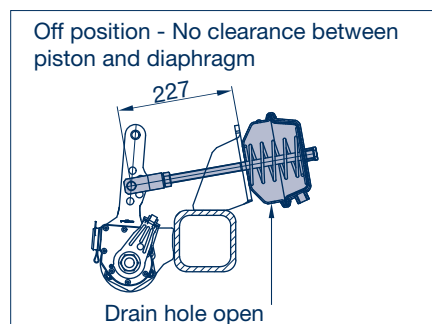

Picture 5



Repair guide!
Comply with the installation instructions for the slack adjuster or section 13 when connecting the push rod or yoke to the slack adjuster.

Do not pull out the push rod of the brake cylinder during installation or adjustment work.

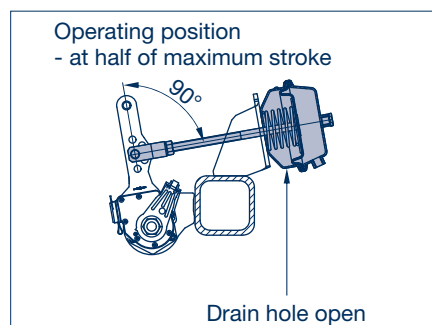

Picture 6

15.4 Installation spring brake cylinder (410)

- [10] Remove the wind off bolt from the retaining fixture. The wind off bolt device consists of the threaded rod (1), washer (2), nut (3) and split pin (4).
For new versions, a protection cap with thread (5) replaces the split pin.

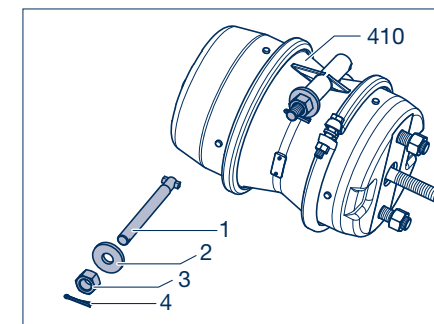

Picture 7

- [11] Fold open the plug (6) on top of the spring brake cylinder (410).
 - [12] Apply min. 6 bar to compressed air connection 1.2.
 - [13] Insert the wind off bolt (1) into the cylinder and clip it into place.
 - [14] Fit the washer (2) and hexagon nut (3) onto the wind - off bolt and use a ring spanner (SW 24) to fully compress the spring. (Brake off position.)
- 👉 See steps [1] - [9] for further assembly steps for the diaphragm cylinder.

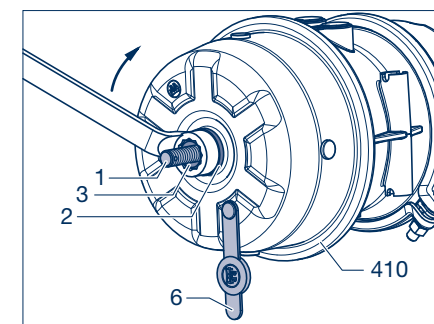

Picture 8

- [15] Remove the wind off bolt to release the spring after installing the cylinder and insert it into the corresponding fixture.
- [16] Tighten the nut to 20 Nm.
- [17] Insert the plug (6) back into the brake cylinder.
- [18] Secure and adjust the slack adjuster in accordance to section 12.
- [19] Tighten the compressed air connections (SW 24) and the plug to 45 Nm.



Note:
We recommend only installing one brand of brake cylinders on any particular vehicle!

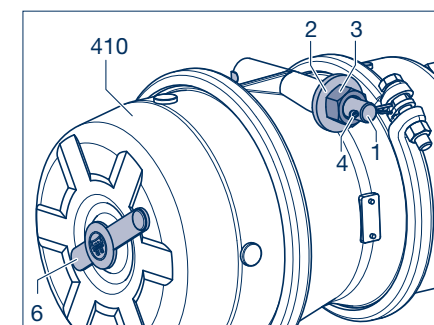

Picture 9

16 Digital ECOMETER

16.1 Function

A minicomputer that is protected from water and dirt counts the wheel revolutions using a magnet and a reed contact.

The tyre rolling circumference is set initially and cannot be changed subsequently.

There is a sensed area behind the display disc which is indicated by the two protruding BPW logos. The display is activated by bringing a metallic object (ferromagnetic) close to the sensed area of the logo.

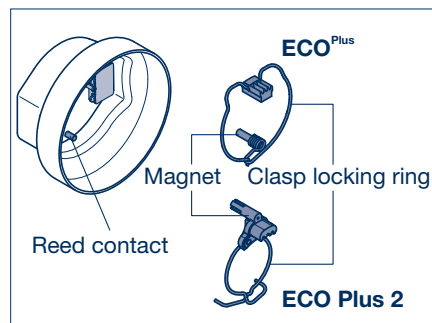

Picture 1

16.2 Start-up / Setting the tyre rolling circumference

On delivery, the digital ECOMETER is in test mode. Bringing a metallic object (ferromagnetic) close to the sensed area on the display causes „CONT“ to be displayed. „REED“ is displayed when the reed contact is activated by the magnet.

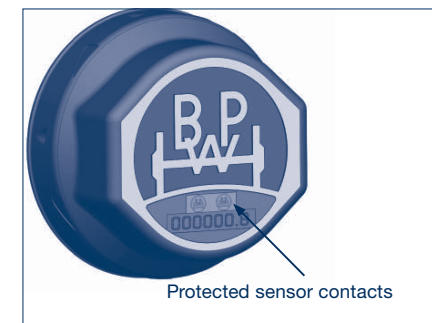

Picture 4

Setting the tyre rolling circumference

The unit is changed to setting mode by touching the reed contact in the hub cap with the magnet (on the clasp locking ring) and at the same time bringing a metallic object (ferromagnetic) close to the sensed area on the outside of the display.

The display goes out if the setting procedure is interrupted for a long period. Pressing any contact resumes the setting procedure from the point at which it was interrupted.

The display „9-U3248“ appears for about 10 seconds as identification of setting mode:

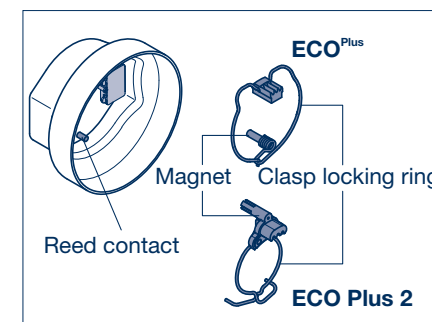

Picture 5

- [1] Pass the magnet over the reed contact. The flashing digit can be incremented by one every time the sensed area on the outside of the display is activated (by a metallic object). After reaching 9, the digit reverts to 0, etc.
- [2] Pass the magnet over the reed contact in the hub cap again. The next digit flashes. Set this one as well by activating the sensed area on the outside of the display. Repeat this procedure until the digits „3248“ have been changed to the precise tyre rolling circumference that is required. This confirms the set tyre circumference.

See the table on page 132 for rolling circumferences.

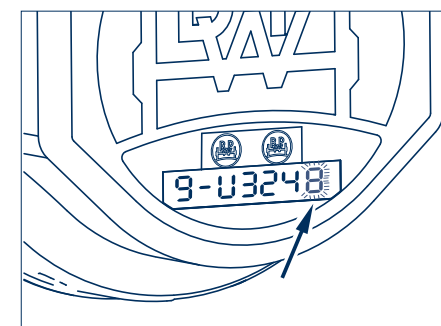

Picture 6



Repair guide!

The ECOMETER is not allowed to be installed, removed or set in a potentially explosive atmosphere.

Renew the unit in case of damage to the housing, the battery compartment or battery cables, the casting compound or other damage to the unit.

Protect the reed contact in the cap against damage. Do not stack the caps one inside the other, for example.

The ECOMETER for ECO Plus 2 axes with bayonet lock must be mounted with a new O-ring.

The ECOMETER for ECO Plus axes must be fitted and dismantled using only torque controlled (not impact!) airguns or manually with a torque wrench. Do not bend the magnet with the spring when installing and removing.

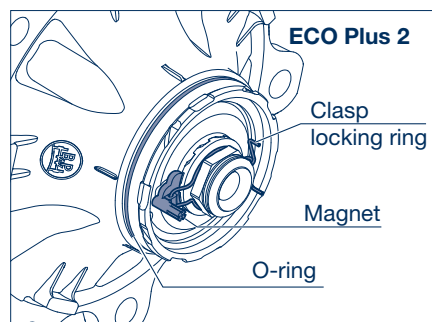

Picture 2

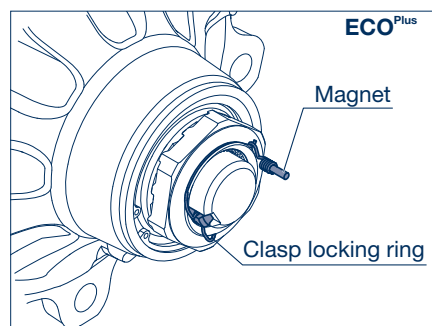

Picture 3

16 Digitaler ECOMETER

- [3] Setting mode is exited by changing the first digit from 9 to 0: When the nine is flashing, it can be reduced from nine to zero by activating the sensed area (with a metallic material). This confirms the set tyre circumference.

Note:
Following this, it is no longer possible to change the set value for the tyre rolling circumference!

- [4] The display switches off automatically.

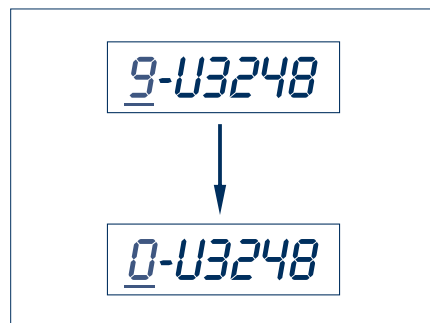

Picture 7

Rolling circumferences

The measurements are based according to standard ETRTO. Data of various tyre manufacturers can slightly deviate.

Tyre size	Rolling circumference ± 2%
245/70 R 19.5	2559 mm
255/60 R 19.5	2469 mm
265/70 R 19.5	2644 mm
285/70 R 19.5	2730 mm
385/55 R 19.5	2785 mm
425/55 R 19.5	2937 mm
435/50 R 19.5	2840 mm
445/45 R 19.5	2730 mm
455/65 R 19.5	3251 mm
10.00 R 20	3209 mm
11 R 22.5	3203 mm
12 R 22.5	3306 mm
275/70 R 22.5	2922 mm
315/60 R 22.5	2879 mm
315/80 R 22.5	3282 mm
385/55 R 22.5	3018 mm
385/65 R 22.5	3248 mm
425/65 R 22.5	3406 mm
445/65 R 22.5	3485 mm
455/40 R 22.5	2850 mm
455/45 R 22.5	3013 mm

16.3 Installation

- [1] Remove the hub cap and hooked spring ring, see also chapter 6.1.

ECO Plus 2

- [2] Insert a new retaining key with integrated magnet into the recess in the axle bolt and the gearing of the toothed lock washer. (Do not turn back the axle screw.)

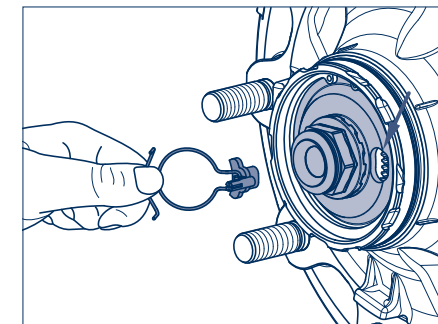

Picture 8

- [3] Insert the clasp locking ring into the annular groove on the end of the hexagon profile of the axle bolt and make sure it is exactly seated. Press the wire into the annular groove if necessary.

- [4] Insert the new O-ring into the groove in the wheel hub.

- [5] After setting the tyre rolling circumference, mount the ECOMETER as described on page 60 (steps 36 - 39).

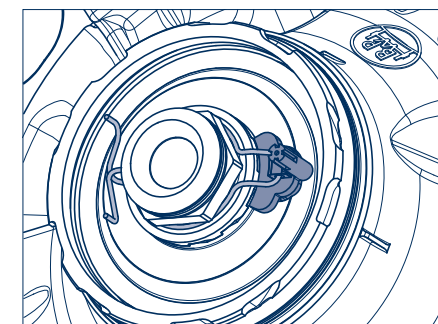

Picture 9

ECO^{Plus}

- [2] Insert the retaining key of the new clasp locking ring with integrated magnet into the groove between the axle stub and the nut. (Do not turn back the axle nut.)

- [3] Hook the clasp locking ring behind the edge of the axle nut. It is essential to hook in the safety lock on the clasp locking ring.

- [4] After setting the tyre rolling circumference, apply a thin coat of BPW special longlife grease ECO-Li^{Plus} to the ECOMETER in the area of the connection thread.

- [5] Screw ECOMETER onto the wheel hub and tighten to the tightening torque of 800 Nm.

Important!
Do not use an impact driver.

Repair guide!
Do not bend the magnet with the spring during installation and removal.

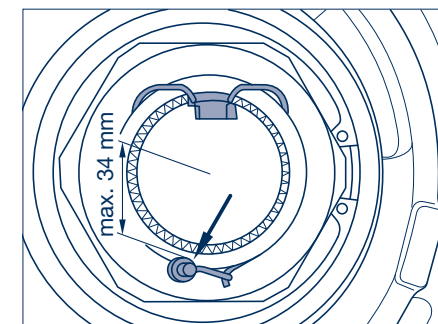

Picture 10

16 Digitaler ECOMETER

Reading out

Pass a ferromagnetic material over the sensed area to activate it:

First, the mileage appears (value in kilometres, e.g. „000567.3“) and then the set tyre rolling circumference (value in mm, e.g. „-U3248“).

The battery voltage is too low if the mileage display flashes during the read out. Fit a new battery.

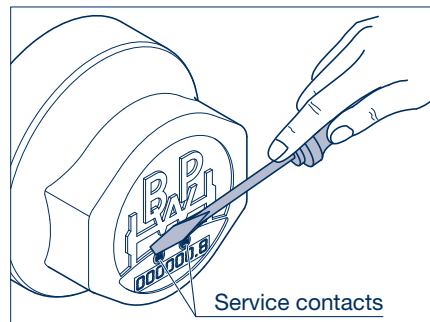

Picture 11

16.4 Battery

The ECOMETER is only allowed to be operated with genuine BPW batteries (code number 02.0130.97.00).



Warning!
The ECOMETER is not allowed to be installed, removed or set in a potentially explosive atmosphere.

If the battery voltage drops below a specific value, the mileage display starts flashing during the display readout and a new battery should be fitted.

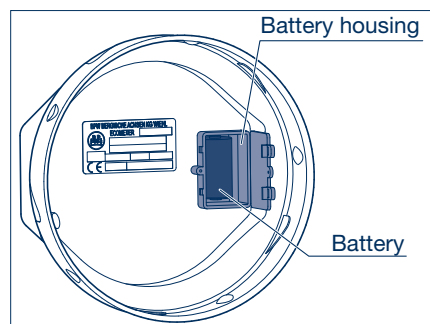

Picture 12

Fitting a new battery

- [1] Remove the ECOMETER from the hub.
- [2] Unscrew the battery housing.
- [3] Fit a new battery (code number 02.0130.97.00). The display shows the current battery voltage.

The voltage of a new battery should not be less than 3 volts.

- [4] Carefully close the battery compartment cover and and refit the retaining screw.

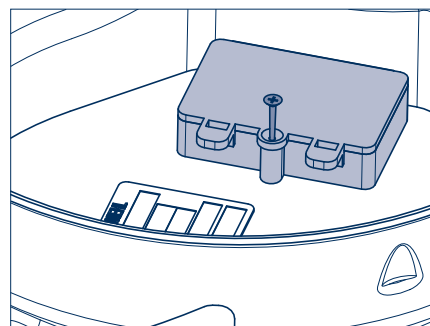

Picture 13

After the battery has been changed, the program and the display are resumed automatically (the distance value in kilometres continues to be stored in temporary memory).

Damage

Renew the unit in case of damage to the housing, the battery compartment or battery cables, the casting compound or other damage to the unit.

Disposal

Remove the battery from the ECOMETER. Dispose of the ECOMETER and the battery in accordance with the relevant national regulations.

16.5 Modification

When converting from the digital ECOMETER to the mechanical ECOMETER or BPW hub cap without kilometre counter, remove the clasp locking ring with magnet and install the standard clasp locking ring without magnet (see illustration).

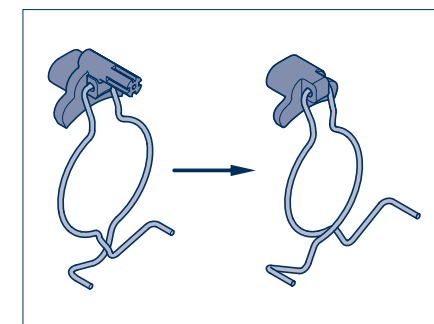

Picture 14



BPW-WH-HKN 35191601e

BPW is a globally leading manufacturer of intelligent running gear systems for trailers and semi-trailers. As an international mobility and system partner, we offer a wide range of solutions for the transport industry from a single source, from axle to suspension and brake to user-friendly telematics applications.

We thereby ensure outstanding transparency in loading and transport processes and facilitate efficient fleet management. Today, the well-established brand represents an international corporation with a wide product and service portfolio for the commercial vehicle industry. Offering running gear systems, telematics, lighting systems, composite solutions and trailer superstructures, BPW is the right system partner for automotive manufacturers.

BPW, the owner-operated company, consistently pursues one target: To always give you exactly the solution which will pay off. To this end, we focus our attention on uncompromising quality for high reliability and service life, weight and time-saving concepts for low operating and maintenance costs as well as personal customer service and a close-knit service network for quick and direct support. You can be sure that with your international mobility partner BPW, you always use the most efficient method.

Your partner on the path to economic viability



BPW Bergische Achsen Kommanditgesellschaft

Postbox 12 80 · 51656 Wiehl, Germany · Phone +49 (0) 2262 78-0
info@bpw.de · www.bpw.de